



CITY OF DANBURY
155 DEER HILL AVENUE
DANBURY, CONNECTICUT 06810

CHARLES J. VOLPE, JR
PURCHASING AGENT

(203) 797-4571 PHONE
(203) 796-1527 FAX
c.volpe@ci.danbury.ct.us

January 5, 2012

ADDENDUM #1

To

Bid #09-11-12-01 "Partial Window/Door Replacement & Abatement at the Danbury High School"

This addendum shall be part of the Purchasing documents for the above captioned Bid. This addendum is to be acknowledged by the bidder by signing as provided below and returning with the bidder's proposal.

SEE ATTACHED: ADDENDUM NO. 1, Dated January 5, 2012, Pages 1 – 4 plus related attachments

BID OPENING: Remains the same – Thursday, January 12, 2012, 10:00 AM

Receipt of the addendum is hereby acknowledged.

Bidder _____

Signature _____

Title _____

Date _____

Charles J. Volpe, Jr.
Purchasing Agent
City of Danbury

ADDENDUM NO. 1

OWNER: CITY OF DANBURY
DEPARTMENT OF PUBLIC WORKS
155 DEER HILL AVENUE
DANBURY, CT 06810

PROJECT NAME: PARTIAL WINDOW/DOOR REPLACEMENT AND ABATEMENT
AT THE: DANBURY HIGH SCHOOL

This Addendum is hereby included in and made a part of the Contract Documents, dated 12/14/11 whether or not attached thereto.

All requirements of the original project specifications and drawings shall remain in force except as amended by this addendum.

DATE: JANUARY 5, 2012

THIS ADDENDUM CONSISTS OF FOUR (4) PAGES WITH TWO (2) SKETCHES ATTACHED. IN ADDITION, THE PRE-BID MEETING MINUTES AND SUBMITTED RFI'S BY CONTRACTORS ARE ENCLOSED.

THE FOLLOWING ARE MODIFICATIONS, CLARIFICATIONS, DELETIONS OR ADDITIONS TO THE SPECIFICATIONS:

INFORMATION TO BIDDERS: PAGE I-3, ARTICLE 10, ADDENDA AND INTERPRETATIONS:

Delete "at least five (5) days prior to the date fixed for the opening of bids."
Add "by 1/6/12 by 12:00 PM."

INFORMATION TO BIDDERS: PAGE I-4, ARTICLE 12, TIME LIMIT:

Delete the first sentence in its entirety and **Add** the following:

The **Abatement Contractor** guarantees that he/she shall complete all work under Project No. 10-54 within **thirty (30) calendar days** with a start of construction date on **June 26, 2012**.

The **Window/Door Replacement Contractor** guarantees that he/she shall complete all work under Project No. 10-54 within **sixty (60) calendar days** with a start of construction date on **June 26, 2012**.

SPECIFICATION SECTION: 00800-1, 1.3 (A) (1):

Delete in its entirety and **Add** the following:

Monday through Friday Summer work hours 7:00 AM to 9:30 PM, no noise after 7:00 AM or after 8:00 PM. Saturday work hours 8:00 AM to 8:00 PM; no noise before 8:00 AM or after 8:00 PM. Sunday work hours 10:00 AM to 8:00 PM; no noise before 10:00 AM or after 8:00 PM. Monday through Friday: Work allowed from 7:00 AM to 9:30 PM with no noisy work after 8:00 PM.

SPECIFICATION SECTION: 01100-4, 1.10 (A):

Add the following:

2. For verification of field conditions:
January 1, 2012 through June 25, 2012:
 - a. 3:00 PM through 8:00 PM only when programs and school occupancy are not disrupted and with the approval of the Owner. Please contact Rich Jalbert (203) 797.4835

SPECIFICATION SECTION: 01100-5, 1.12 (B) (2):

Delete March 23, 2012 and Add initial delivery date of May 1, 2012.

SPECIFICATION SECTION: 01100-5, 1.12 (B) (3):

Delete completion date August 26, 2012.

Add Completion Date: July 25, 2012 (Abatement)
Add Completion Date: August 26, 2012 (Windows/Doors)

SPECIFICATION SECTION: 01300-4, 3.6 (H):

Add the following:

Allow 5 working days for processing each re-submittal.

SPECIFICATION SECTION: 01325-3, 3.7 (C)

Delete paragraph "C" and substitute with the following:

All work is to take account for an award period, submittal period, and a shop fabrication period as indicated in Section 01100 (1.12) work sequence. All materials are to be on site prior to starting of the physical construction work. The Windows and Doors storage is to be in containers on site, (in areas indicated on plans) provided by the Window and Door Contractor.

SPECIFICATION SECTION: 01700-2, 1.7 (B):

Delete sentence in its entirety and Add the following:

- B. The Owner shall file and General Contractor obtain the Building Permit. The Contractor shall pay a State permit fee of .26 cents per \$1,000 of contract value.

THE FOLLOWING ARE MODIFICATIONS, CLARIFICATIONS, DELETIONS OR ADDITIONS TO THE DRAWINGS BY DESCRIPTION. THE DRAWINGS ARE NOT RE-ISSUED:

DRAWING S-1 – WINDOW INSTALLATION SEQUENCING:

Revise the finish date for Area 3C from 8/24/12 to 8/26/12.

DRAWING S-1:

Refer to SKB-2 for revisions to Area 1 and Area 3C.

DRAWING RM-300 THROUGH RM-305:

Add the following note to note No. 2:

Clarification of Abatement Procedures:

It is the intent of Note 2 on the drawings and articles 02081-3 (3.1) (A), 02081-4 (3.1) (I), and 02081-4 (3.1) (J) of the specifications that performance-based disposal, rather than risk-based disposal, of PCB (both bulk materials and waste) be implemented. This method does not require approval from EPA. Because asbestos is also present in the caulk and glazing putty, all materials must be disposed as mixed waste.

DRAWING A-725:

Revise window designation at window No. 222 from W-27 to W-27A.

DRAWING A-727:

Revise window designation at window No. 314 from W-12 to W-12B.

DRAWING A-728:

Revise window designation at window No. 408 from W-12 to W-12B.

DRAWING A-729:

Revise window designation at window No. 505 from W-12 to W-12B.

DRAWINGS A-725 THROUGH A-729 – GENERAL WINDOW NOTES:

Add the following Note Number (15):

“Removal and disposal of all existing interior window blinds shall be performed by the Abatement Contractor where abatement of windows is performed. Blinds at windows which are not being abated but are being replaced shall be removed and disposed of by the Window Contractor.”

DRAWINGS A-750 AND A-751 – REMARKS NOTES:

Delete remarks note No. 2 at the following Door Numbers: 115, 116, 117, 118, 204, 205, 206, 209, 217, 220, 221, 302, 305, 306, 307, 308, 309, 310, 311, 312, 313.

DRAWINGS A-750 AND A-751 – GENERAL DOOR NOTES:

At Note No. 15 **Add** the following after F-11: “and F-15”:

At Note No. 16 **Delete** the words “doors and”

Add the following new note:

“21. Guard bar shall be square tubing with capped ends min. 2” x 2” painted steel tube at hollow metal frames and clear anodized aluminum at frames with aluminum capping. Guard bars shall be mechanically fastened to door frames.”

DRAWING A-750 – DETAIL NO. 1, REMOVABLE STOP:

Add the following note:

Provide aluminum stop at aluminum clad framing.”

DRAWING A-752 – FRAME DETAILS:

Refer to SKB-1 for additional capping details.

END OF ADDENDUM NO. 1

The following ATTACHMENTS are being provided for informational purposes:

Bidder RFI Responses (In the event of a discrepancy between these responses and the contract documents the contract documents shall prevail unless modified by addendum.)

Bid RFI-01 dated 12/21/11 (1 page)
Bid RFI-02 dated 12/21/11 (1 page)
Bid RFI-03 dated 12/21/11 (1 page)
Bid RFI-04 dated 12/22/11 (1 page)
Bid RFI-05 dated 12/22/11 (1 page)
Bid RFI-06 dated 12/22/11 (1 page)
Bid RFI-07 dated 12/27/11 (1 page)
Bid RFI-08 dated 12/27/11 (1 page)
Bid RFI-09 dated 12/27/11 (1 page)
Bid RFI-10 dated 12/28/11 (1 page)
Bid RFI-11 dated 12/28/11 (1 page)
Bid RFI-12 dated 12/29/11 (1 page)
Bid RFI-13 dated 01/03/12 (1 Page)
Bid RFI-14 dated 01/04/12 (1 Page)
Bid RFI-15 dated 01/05/12 (3 Pages)

Minutes of Pre Bid Meeting and sign-in sheet held on December 28, 2011

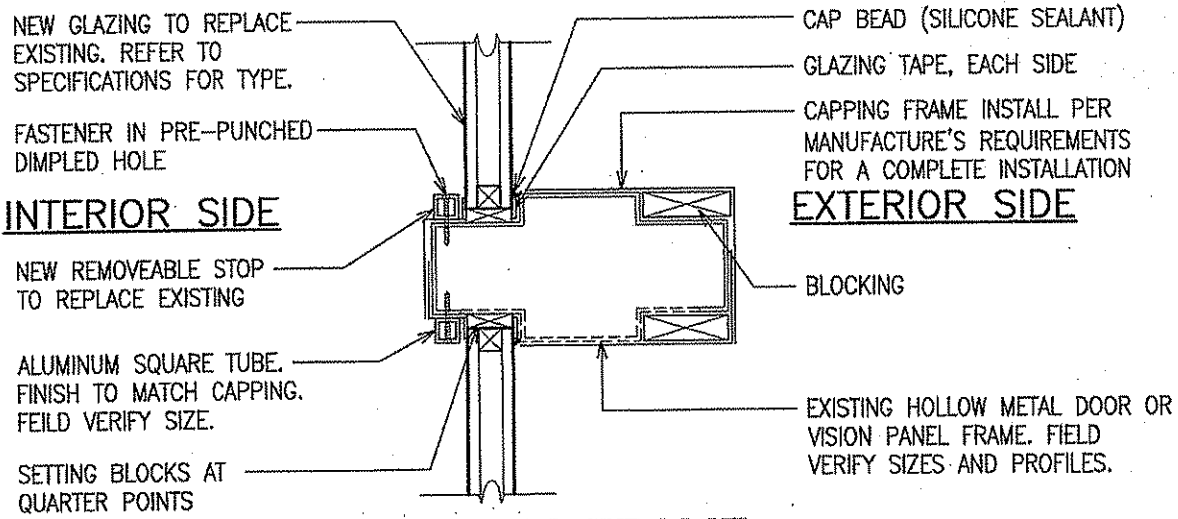

DETAIL - CAPPING FRAME @ MULLION (VERTICAL AND HORIZONTAL)

1 SCALE: 3" = 1'-0"

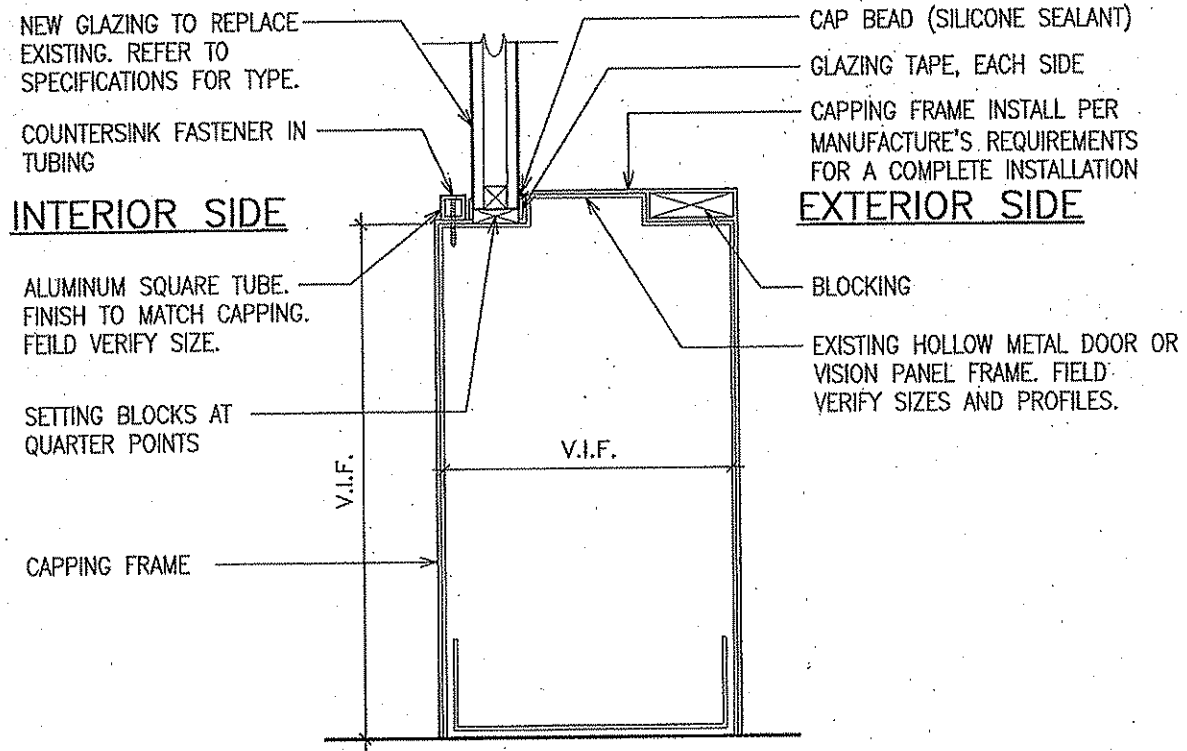

DETAIL - CAPPING FRAME @ BASE

2 SCALE: 3" = 1'-0"

NOTE: THIS DRAWING INDICATES CLARIFICATION ONLY. ALL INFORMATION ON ORIGINAL CONTRACT DOCUMENT SHALL PERTAIN UNLESS SPECIFICALLY CHANGED BY THIS DRAWING.

**FULLER
D'ANGELO
P.C.**
**ARCHITECTS
PLANNERS**
48 ENGLEWOOD ROAD, DANBURY, NEW YORK 10828
TEL: 914.326.4444 FAX: 914.326.1117
WWW.FULLERDANGELO.COM
Copyright 2011. All Rights Reserved by FULLER & D'ANGELO P.C.

JOB NAME:
DANBURY SCHOOLS
DANBURY HIGH SCHOOL
PARTIAL WINDOW / DOOR REPLACEMENT
43 CLAPBOARD RIDGE ROAD, DANBURY, CT 06811

DRAWING TITLE:
DETAILS - CAPPING FRAME @
BASE AND MULLION
(REF. DWG. A-752)

ISSUED TO	DATE
ADDENDUM No.1	01-04-2012
SCALE: AS NOTED	PROJECT NO. 11029.00
DATE: 01-04-2012	DRAWING NO. SKB-1

1 SITE PLAN AND SEQUENCING
SCALE: N.T.S.

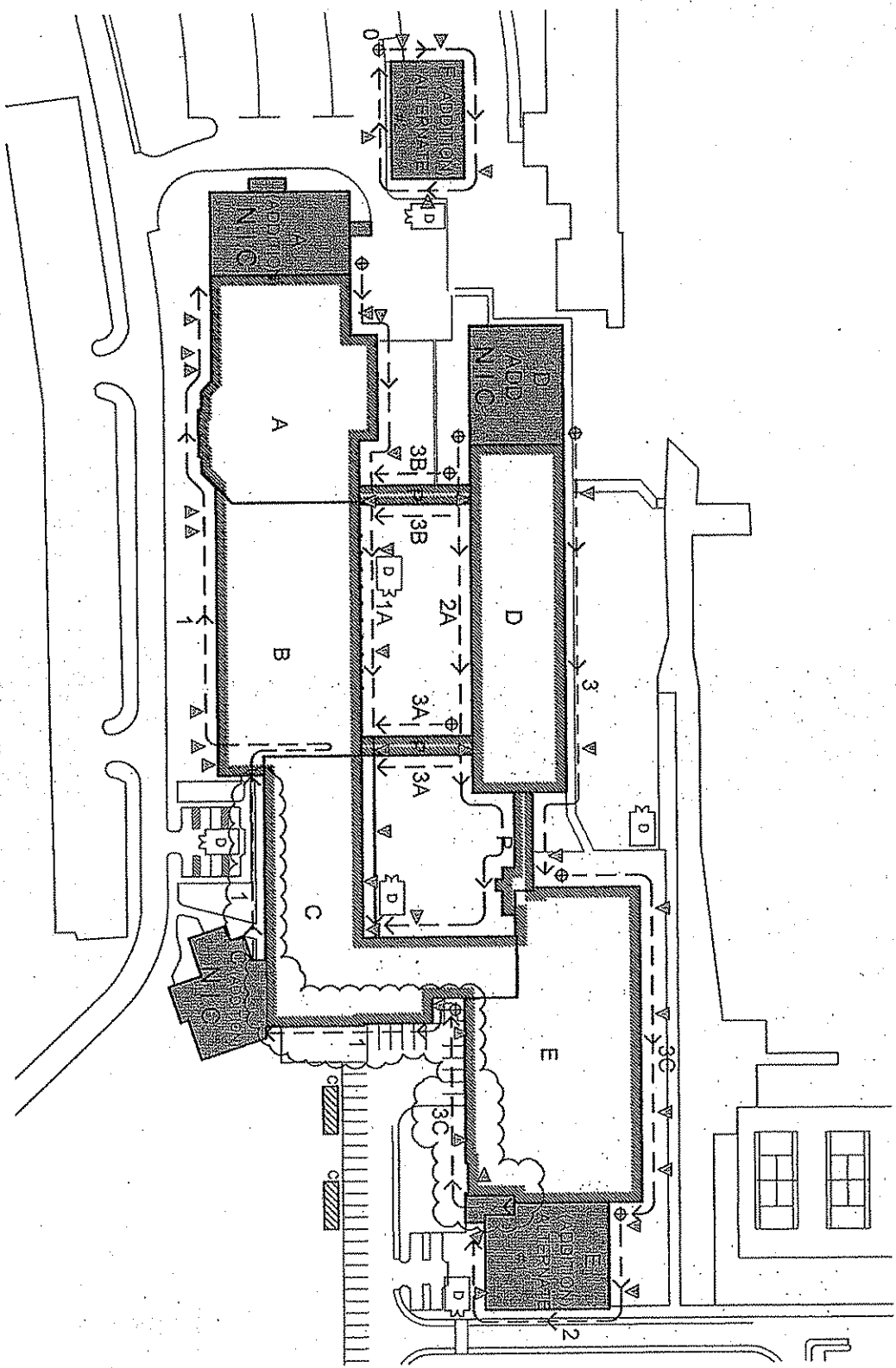

NOTE: THIS DRAWING INDICATES CLARIFICATION ONLY. ALL INFORMATION ON ORIGINAL CONTRACT DOCUMENT SHALL PERTAIN UNLESS SPECIFICALLY CHANGED BY THIS DRAWING.

**FULLER
D'ANGELO
P.C.**
**ARCHITECTS
PLANNERS**
48 KNOXWOOD ROAD, ELMSFORD NEW YORK 10623
TEL: 914.899.4444 FAX: 914.899.1777
WWW.FULLERDANGELO.COM
Copyright 2011. All Rights Reserved by FULLER & D'ANGELO P.C.

JOB NAME:
DANBURY SCHOOLS
DANBURY HIGH SCHOOL
PARTIAL WINDOW / DOOR REPLACEMENT
43 CLAPBOARD RIDGE ROAD, DANBURY, CT 06811

DRAWING TITLE:
SITE PLAN AND SEQUENCING
(REF. DWG. S-1)

ISSUED TO	DATE
ADDENDUM No.1	01-04-2012
SCALE: AS NOTED	PROJECT NO. 11029.00
DATE: 01-04-2012	DRAWING NO. SKB-2

DANBURY PUBLIC SCHOOLS
DANBURY HIGH SCHOOL
PARTIAL WINDOW / DOOR REPLACEMENT AND ABATEMENT

SECTION 00201

RFI FORM

BID RFI-01

CONTRACTOR'S REQUEST FOR INFORMATION NO. 1
NO: _____

OWNER'S RFI

NAME OF PROJECT: DANBURY HIGH SCHOOL PARTIAL WINDOW/ DOOR REPLACEMENT
AND ABATEMENT PROJECT

NAME OF OWNER: CITY OF DANBURY

DATE: 12/21/11

A/E PROJECT NO: 11029.00

FULLER D'ANGELO PC ARCHITECTS AND PLANNERS

45 KNOLLWOOD ROAD

ELMSFORD, NEW YORK 10523

TEL: 914.592.4444 FAX: 914.592.1717

FROM (CO. NAME): CHERRY HILL GLASS

CONTACT NAME: JULIE GOOSMASTER

SUBJECT: SCOPE

DISCIPLINE/TRADE: WINDOWS & DOORS BID PACKAGE ONE

DWG./SPEC. REFERENCE: _____

QUESTION:

FIELD CONDITION SCOPE STATES AC UNITS TO BE REPLACED

DRAWING/SPEC WITH NEW.

DISCREPANCY 1. DO WE SUPPLY THE NEW UNITS?

OWNER CHANGE 2. IF SO IS THERE A SPECIFICATION?

CLARIFICATION _____

CONTRACTOR'S SUGGESTION (IF APPLICABLE): _____

1. WINDOW CONTRACTOR IS RESPONSIBLE FOR THIS WORK
ANSWER
2. REFER TO THE "ME" DRAWINGS

ARCHITECT'S SIGNATURE: [Signature]

DATE: 12.21.11

Note: review and any responses to this request for information by the architect/engineer is strictly for design intent only and does not constitute acknowledgement, or acceptance of any cost or schedule implications unless specifically presented by the contractor. By submission of this request for information, the contractor assumes all responsibility in the absence of an approved change order or work directive.

END OF SECTION

FULLER AND D'ANGELO, P.C.
ARCHITECTS AND PLANNERS

DANBURY PUBLIC SCHOOLS
DANBURY HIGH SCHOOL
PARTIAL WINDOW / DOOR REPLACEMENT AND ABATEMENT

SECTION 00201

RFI FORM

BID RFI-02

CONTRACTOR'S REQUEST FOR INFORMATION NO. 2
NO: _____

OWNER'S RFI

NAME OF PROJECT: DANBURY HIGH SCHOOL PARTIAL WINDOW/ DOOR REPLACEMENT
AND ABATEMENT PROJECT

NAME OF OWNER: CITY OF DANBURY

DATE: 12/21/11

A/E PROJECT NO: 11029.00

FULLER D'ANGELO P.C ARCHITECTS AND PLANNERS

45 KNOLLWOOD ROAD

ELMSFORD, NEW YORK 10523

TEL: 914.592.4444 FAX: 914.592.1717

FROM (CO. NAME): EMERY HILL GLASS

CONTACT NAME: JULIE GADNATTER

SUBJECT: SCOPE

DISCIPLINE/TRADE: WINDOWS & DOORS BID PACKAGE ONE

DWG./SPEC. REFERENCE: _____

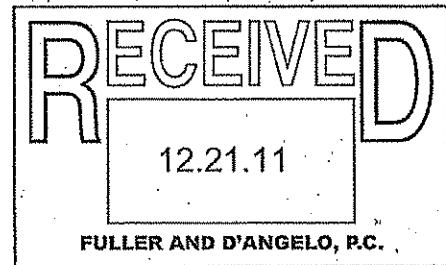

QUESTION:

FIELD CONDITION WHO SUPPLIES THE NEW HOLLOW METAL
DRAWING/SPEC DOORS AND HARDWARE IN EXISTING
DISCREPANCY FRAMES?
OWNER CHANGE _____
 CLARIFICATION _____
CONTRACTOR'S SUGGESTION (IF APPLICABLE): _____

ANSWER:

BID PACKAGE 1 THE WINDOW CONTRACTOR IS RESPONSIBLE FOR THIS WORK

ARCHITECT'S SIGNATURE: [Signature]
DATE: 12.21.11

Note: review and any responses to this request for information by the architect/engineer is strictly for design intent only and does not constitute acknowledgement or acceptance of any cost or schedule implications unless specifically presented by the contractor. By submission of this request for information, the contractor assumes all responsibility in the absence of an approved change order or work directive.

END OF SECTION

FULLER AND D'ANGELO, P.C.
ARCHITECTS AND PLANNERS

DANBURY PUBLIC SCHOOLS
DANBURY HIGH SCHOOL
PARTIAL WINDOW / DOOR REPLACEMENT AND ABATEMENT

SECTION 00201

RFI FORM

BID RFI-03
OWNER'S RFI

CONTRACTOR'S REQUEST FOR INFORMATION NO. 3
NO: _____

NAME OF PROJECT: DANBURY HIGH SCHOOL PARTIAL WINDOW DOOR REPLACEMENT
AND ABATEMENT PROJECT

NAME OF OWNER: CITY OF DANBURY

DATE: _____

A/E PROJECT NO: 11029.00

FULLER D'ANGELO PC ARCHITECTS AND PLANNERS

45 KNOLLWOOD ROAD

ELMSFORD, NEW YORK 10523

TEL: 914.592.4444 FAX: 914.592.1717

FROM (CO. NAME): CHERRY HILL GLASS

CONTACT NAME: JULIE GOOBMASTER

SUBJECT: ALTERNATE #3

DISCIPLINE/TRADE: WINDOWS & DOORS BID PACKAGE ONE

DWG./SPEC. REFERENCE: A 751

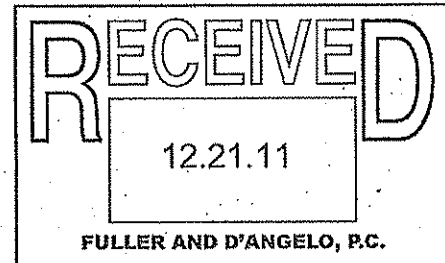

QUESTION:

- FIELD CONDITION ALTERNATE IS TO REPLACE ALUMINUM
- DRAWING/SPEC FLUSH PANEL DOORS WITH FRP. DOOR
- DISCREPANCY SCHEDULE SHOWS DOORS 1309, 310 AS FRP.
- OWNER CHANGE ARE THESE TO BE FRP IN THE BASE BID
- CLARIFICATION _____
- CONTRACTOR'S SUGGESTION (IF APPLICABLE): _____

ANSWER

YES, THESE DOORS ARE BASE BID

ARCHITECT'S SIGNATURE: [Signature]
DATE: 12.21.11

Note: review and any responses to this request for information by the architect/engineer is strictly for design intent only and does not constitute acknowledgement or acceptance of any cost or schedule implications unless specifically presented by the contractor. By submission of this request for information, the contractor assumes all responsibility in the absence of an approved change order or work directive..

END OF SECTION

FULLER AND D'ANGELO, P.C.
ARCHITECTS AND PLANNERS

DANBURY PUBLIC SCHOOLS
DANBURY HIGH SCHOOL
PARTIAL WINDOW / DOOR REPLACEMENT AND ABATEMENT

SECTION 00201

RFIFORM

BID RFI-04
OWNER'S RFI

CONTRACTOR'S REQUEST FOR INFORMATION NO. 4
NO: _____

NAME OF PROJECT: DANBURY HIGH SCHOOL PARTIAL WINDOW/ DOOR REPLACEMENT
AND ABATEMENT PROJECT

NAME OF OWNER: CITY OF DANBURY

DATE: 12/22/11

A/E PROJECT NO: 11029.00

FULLER D'ANGELO PC ARCHITECTS AND PLANNERS

45 KNOLLWOOD ROAD

ELMSFORD, NEW YORK 10523

TEL: 914.592.4444 FAX: 914.592.1717

FROM (CO. NAME): CHERRY HILL GLASS

CONTACT NAME: JULIE GOODMAN

SUBJECT: _____

DISCIPLINE/TRADE: WINDOWS & DOORS BID PACKAGE ONE

DWG./SPEC. REFERENCE: A-150

QUESTION:

FIELD CONDITION DOOR 115 SHOWS A EXISTING HOLLOW METAL
 DRAWING/SPEC FRAME TYPE F-10 NOTES SHOW (2) PRIME AND
 DISCREPANCY PAINT EXISTING FRAME NOTE (4) STATES GLAZ
 OWNER CHANGE EXISTING. WHICH IS CORRECT ?
 CLARIFICATION _____
 CONTRACTOR'S SUGGESTION (IF APPLICABLE): _____

Note no.4 is correct, note no.2 should be deleted. This is typical at all door frames that
are noted to be capped

ARCHITECT'S SIGNATURE: [Signature]
DATE: 12.23.11

Note: review and any responses to this request for information by the architect/engineer is strictly for design intent only and does not constitute acknowledgement or acceptance of any cost or schedule implications unless specifically presented by the contractor. By submission of this request for information, the contractor assumes all responsibility in the absence of an approved change order or work directive.

END OF SECTION

FULLER AND D'ANGELO, P.C.
ARCHITECTS AND PLANNERS

DANBURY PUBLIC SCHOOLS
DANBURY HIGH SCHOOL
PARTIAL WINDOW / DOOR REPLACEMENT AND ABATEMENT

SECTION 00201

RFI FORM

BID RFI-05
OWNER'S RFI

CONTRACTOR'S REQUEST FOR INFORMATION NO. 5
NO: _____

NAME OF PROJECT: DANBURY HIGH SCHOOL PARTIAL WINDOW/ DOOR REPLACEMENT
AND ABATEMENT PROJECT

NAME OF OWNER: CITY OF DANBURY

DATE: 12/22/11

A/E PROJECT NO: 11029.00

FULLER D'ANGELO PC ARCHITECTS AND PLANNERS

45 KNOLLWOOD ROAD

ELMSFORD, NEW YORK 10523

TEL: 914.592.4444 FAX: 914.592.1717

FROM (CO. NAME): EMERY HILL GLASS

CONTACT NAME: JULIE GOODMAN

SUBJECT: _____

DISCIPLINE/TRADE: WINDOWS & DOORS BID PACKAGE ONE

DWG./SPEC. REFERENCE: A-752

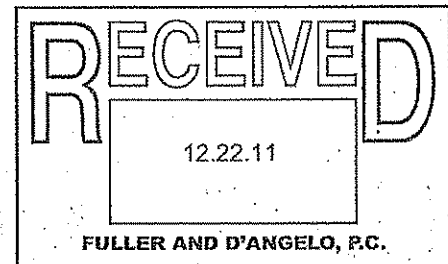

QUESTION:

___ FIELD CONDITION DETAILS SHOW CAPPING FOR THE JAMB
___ DRAWING/SPEC AND HEAD OF THE EXISTING HOLLOW METAL
___ DISCREPANCY FRAMES. THERE ARE NO DETAILS FOR
___ OWNER CHANGE INTERMEDIATE HORIZONTALS, VERTICALS
___ CLARIFICATION OR 12" GASE. PLEASE PROVIDE.

___ CONTRACTOR'S SUGGESTION (IF APPLICABLE): _____

Additional details will be issued by ANSWER
addendum at a later date.

ARCHITECT'S SIGNATURE: [Signature]
DATE: 12.23.11

Note: review and any responses to this request for information by the architect/engineer is strictly for design intent only and does not constitute acknowledgement or acceptance of any cost or schedule implications unless specifically presented by the contractor. By submission of this request for information, the contractor assumes all responsibility in the absence of an approved change order or work directive.

END OF SECTION

FULLER AND D'ANGELO, P.C.
ARCHITECTS AND PLANNERS

DANBURY PUBLIC SCHOOLS
DANBURY HIGH SCHOOL
PARTIAL WINDOW / DOOR REPLACEMENT AND ABATEMENT

SECTION 00201

RFI FORM

BID RFI-06

OWNER'S RFI

CONTRACTOR'S REQUEST FOR INFORMATION NO. 6
NO: _____

NAME OF PROJECT: DANBURY HIGH SCHOOL PARTIAL WINDOW/ DOOR REPLACEMENT
AND ABATEMENT PROJECT

NAME OF OWNER: CITY OF DANBURY

DATE: _____

A/E PROJECT NO: 11029.00

FULLER D'ANGELO PC ARCHITECTS AND PLANNERS

45 KNOLLWOOD ROAD

ELMSFORD, NEW YORK 10523

TEL: 914.592.4444 FAX: 914.592.1717

FROM (CO. NAME): EMERY HILL GLASS

CONTACT NAME: JULIE GOODMAN

SUBJECT: _____

DISCIPLINE/TRADE: WINDOWS & DOORS BID PACKAGE ONE

DWG./SPEC. REFERENCE: A-750

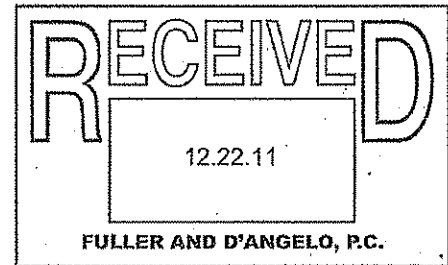

QUESTION:

FIELD CONDITION NOTE 16 UNDER GENERAL NOTES STATES
 DRAWING/SPEC HOLLOW METAL DOORS TO BE REPAINTED.
 DISCREPANCY DOOR SCHEDULE SHOWS NEW HOLLOW
 OWNER CHANGE METAL DOORS.
 CLARIFICATION _____
 CONTRACTOR'S SUGGESTION (IF APPLICABLE): _____

ANSWER

Delete the words " DOORS AND "

ARCHITECT'S SIGNATURE: [Signature]

DATE: 12.23.11

Note: review and any responses to this request for information by the architect/engineer is strictly for design intent only and does not constitute acknowledgement or acceptance of any cost or schedule implications unless specifically presented by the contractor. By submission of this request for information, the contractor assumes all responsibility in the absence of an approved change order or work directive..

END OF SECTION

FULLER AND D'ANGELO, P.C.
ARCHITECTS AND PLANNERS

DANBURY PUBLIC SCHOOLS
DANBURY HIGH SCHOOL
PARTIAL WINDOW / DOOR REPLACEMENT AND ABATEMENT

SECTION 00201

RFI FORM

BID RFI-07

CONTRACTOR'S REQUEST FOR INFORMATION NO. 7
NO: _____

OWNER'S RFI

NAME OF PROJECT: DANBURY HIGH SCHOOL PARTIAL WINDOW/ DOOR REPLACEMENT
AND ABATEMENT PROJECT

NAME OF OWNER: CITY OF DANBURY

DATE: 12/27/11

A/E PROJECT NO: 11029.00

FULLER DANGELO PC ARCHITECTS AND PLANNERS

45 KNOLLWOOD ROAD

ELMSFORD, NEW YORK 10523

TEL: 914.592.4444 FAX: 914.592.1717

FROM (CO. NAME): CHESTNUT HILL GLASS

CONTACT NAME: JULIE GOODMAN

SUBJECT: _____

DISCIPLINE/TRADE: WINDOWS & DOORS BID PACKAGE ONE

DWG./SPEC. REFERENCE: 08520/08130

QUESTION:

FIELD CONDITION 08130 shows CLEAR ANODIZED FINISH

DRAWING/SPEC 08520 shows painted finish

DISCREPANCY IS THIS CORRECT?

OWNER CHANGE _____

CLARIFICATION _____

CONTRACTOR'S SUGGESTION (IF APPLICABLE): _____

ANSWER

PROJECT SPECIFICATIONS ARE CORRECT.

ARCHITECT'S SIGNATURE: [Signature]

DATE: 01.02.12

Note: review and any responses to this request for information by the architect/engineer is strictly for design intent only and does not constitute acknowledgement or acceptance of any cost or schedule implications unless specifically presented by the contractor. By submission of this request for information, the contractor assumes all responsibility in the absence of an approved change order or work directive.

END OF SECTION

FULLER AND D'ANGELO, P.C.
ARCHITECTS AND PLANNERS

DANBURY PUBLIC SCHOOLS
DANBURY HIGH SCHOOL
PARTIAL WINDOW / DOOR REPLACEMENT AND ABATEMENT

SECTION 00201

RFI FORM

B10 RFI-08

CONTRACTOR'S REQUEST FOR INFORMATION NO. 8
NO: _____

OWNER'S RFI

NAME OF PROJECT: DANBURY HIGH SCHOOL PARTIAL WINDOW/ DOOR REPLACEMENT
AND ABATEMENT PROJECT

NAME OF OWNER: CITY OF DANBURY

DATE: 12/27/11

A/B PROJECT NO: 11029.00

FULLER, D'ANGELO PC ARCHITECTS AND PLANNERS

45 KNOELLWOOD ROAD

ELMSFORD, NEW YORK 10523

TEL: 914.592.4444 FAX: 914.592.1717

FROM (CO. NAME): CHEEN HILL GLASS

CONTACT NAME: JULIE GONNASTRE

SUBJECT: _____

DISCIPLINE/TRADE: WINDOWS & DOORS BID PACKAGE ONE

DWG./SPEC. REFERENCE: A7.25, NOTE 15

QUESTION:

- FIELD CONDITION Note 15 states provide & install roller shades
- DRAWING/SPEC per SH drawings. Allowance A is for
- DISCREPANCY roller shades. Confirm roller shades are
- OWNER CHANGE included in this Allowance.
- CLARIFICATION _____
- CONTRACTOR'S SUGGESTION (IF APPLICABLE): _____

ANSWER

CONFIRMED

ARCHITECT'S SIGNATURE: [Signature]
DATE: 01.02.12

Note: review and any responses to this request for information by the architect/engineer is strictly for design intent only and does not constitute acknowledgement or acceptance of any cost or schedule implications unless specifically presented by the contractor. By submission of this request for information, the contractor assumes all responsibility in the absence of an approved change order or work directive.

END OF SECTION

FULLER AND D'ANGELO, P.C.
ARCHITECTS AND PLANNERS

DANBURY PUBLIC SCHOOLS
DANBURY HIGH SCHOOL
PARTIAL WINDOW / DOOR REPLACEMENT AND ABATEMENT

SECTION 00201

RFI FORM

BID RFI - 09

CONTRACTOR'S REQUEST FOR INFORMATION NO. 9
NO: _____

OWNER'S RFI

NAME OF PROJECT: DANBURY HIGH SCHOOL PARTIAL WINDOW/ DOOR REPLACEMENT
AND ABATEMENT PROJECT

NAME OF OWNER: CITY OF DANBURY

DATE: 12/27/11

A/E PROJECT NO: 11029.00

FULLER, D'ANGELO PC ARCHITECTS AND PLANNERS

45 KNOLLWOOD ROAD

ELMSFORD, NEW YORK 10523

TEL: 914.592.4444 FAX: 914.592.1717

FROM (CO. NAME): EMERY HILL GLASS

CONTACT NAME: JULIE GOODMAN

SUBJECT: _____

DISCIPLINE/TRADE: WINDOWS & DOORS BIDDING PACKAGE ONE

DWG./SPEC. REFERENCE: A725 - A729

QUESTION:

FIELD CONDITION THE FOLLOWING WINDOW NUMBERS

DRAWING/SPEC DO NOT SEEM TO BE ON THE WINDOW

DISCREPANCY SCHEDULE 12B-27A.

OWNER CHANGE _____

CLARIFICATION _____

CONTRACTOR'S SUGGESTION (IF APPLICABLE): _____

WINDOW # 222 SHOULD READ W27A IN LIEU OF W27

WINDOW #'s 314,408,505 SHOULD READ W12B IN LIEU ANSWER

OF W12

ARCHITECT'S SIGNATURE: [Signature]

DATE: 01.02.12

Note: review and any responses to this request for information by the architect/engineer is strictly for design intent only and does not constitute acknowledgement or acceptance of any cost or schedule implications unless specifically presented by the contractor. By submission of this request for information, the contractor assumes all responsibility in the absence of an approved change order or work directive.

END OF SECTION

FULLER AND D'ANGELO, P.C.
ARCHITECTS AND PLANNERS

DANBURY PUBLIC SCHOOLS
DANBURY HIGH SCHOOL
PARTIAL WINDOW / DOOR REPLACEMENT AND ABATEMENT

SECTION 00201

REFORM

BID RFI-10

CONTRACTOR'S REQUEST FOR INFORMATION NO. 10
NO. _____

OWNER'S RFI

NAME OF PROJECT: DANBURY HIGH SCHOOL PARTIAL WINDOW/ DOOR REPLACEMENT
AND ABATEMENT PROJECT

NAME OF OWNER: CITY OF DANBURY

DATE: 2/28/11

A/E PROJECT NO: 11029.00

FULLER D'ANGELO PC ARCHITECTS AND PLANNERS
45 KNOLLWOOD ROAD

ELMSFORD, NEW YORK 10523

TEL: 914.592.4444 FAX: 914.592.1717

FROM (CO. NAME): CHERRY HILL GLASS

CONTACT NAME: JULIE GADWARTZ

SUBJECT: SCOPE

DISCIPLINE/TRADE: WINDOWS + DOORS BID PACKAGE ONE

DWG./SPEC. REFERENCE: _____

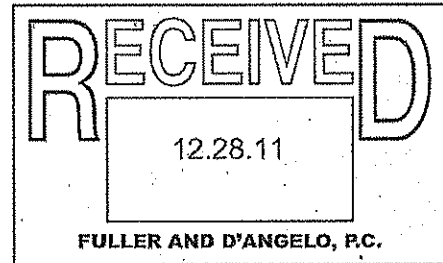

QUESTION:

- FIELD CONDITION HAVE ANY PROVISIONS BEEN MADE TO
- DRAWING/SPEC BE ABLE TO FIELD MEASURE WINDOW
- DISCREPANCY OPENINGS. FINAL SIZES SHOULD BE ON
- OWNER CHANGE THE SHOP DRAWINGS. WOULD MEASURING
- CLARIFICATION NEED TO BE DONE OFF HOURS?
- CONTRACTOR'S SUGGESTION (IF APPLICABLE): _____

ANSWER

THIS WILL BE ADDRESSED IN UPCOMMING ADDENDUM.

ARCHITECT'S SIGNATURE: [Signature]
DATE: 01.02.12

Note: review and any responses to this request for information by the architect/engineer is strictly for design intent only and does not constitute acknowledgement or acceptance of any cost or schedule implications unless specifically presented by the contractor. By submission of this request for information, the contractor assumes all responsibility in the absence of an approved change order or work directive.

END OF SECTION

FULLER AND D'ANGELO, P.C.
ARCHITECTS AND PLANNERS

DANBURY PUBLIC SCHOOLS
DANBURY HIGH SCHOOL
PARTIAL WINDOW / DOOR REPLACEMENT AND ABATEMENT

SECTION 00201

RFI FORM

BID RFI - 11

CONTRACTOR'S REQUEST FOR INFORMATION NO. 11
NO: _____

OWNER'S RFI

NAME OF PROJECT: DANBURY HIGH SCHOOL PARTIAL WINDOW/ DOOR REPLACEMENT
AND ABATEMENT PROJECT

NAME OF OWNER: CITY OF DANBURY

DATE: 12/28/11

A/E PROJECT NO: 11029.00

FULLER DANGELO PC ARCHITECTS AND PLANNERS

45 KNOLLWOOD ROAD

ELMSFORD, NEW YORK 10523

TEL: 914.592.4444 FAX: 914.592.1717

FROM (CO. NAME): CHERRY HILL GLASS

CONTACT NAME: JULIE GOODMAN

SUBJECT: SCOPE

DISCIPLINE/TRADE: WINDOWS & DOORS BID PACKAGE ONE

DWG./SPEC. REFERENCE: _____

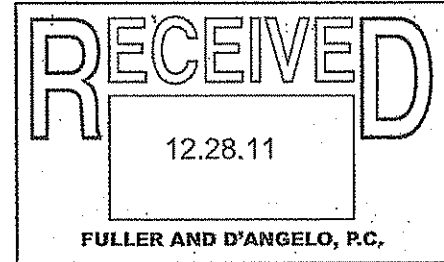

QUESTION:

FIELD CONDITION AT THE WALKTHRU IT WAS STATED
DRAWING/SPEC SUBMITALS BY 2/15 AND WINDOWS ON
DISCREPANCY SITE BY 5/23. HOW LONG IS THE REVIEW
OWNER CHANGE AND APPROVAL GOING TO TAKE?
CLARIFICATION _____
CONTRACTOR'S SUGGESTION (IF APPLICABLE): _____

ANSWER

THIS WILL BE ADDRESSED IN UPCOMMING ADDENDUM.

ARCHITECT'S SIGNATURE: [Signature]

DATE: 01.02.12

Note: review and any responses to this request for information by the architect/engineer is strictly for design intent only and does not constitute acknowledgement or acceptance of any cost or schedule implications unless specifically presented by the contractor. By submission of this request for information, the contractor assumes all responsibility in the absence of an approved change order or work directive.

END OF SECTION

FULLER AND D'ANGELO, P.C.
ARCHITECTS AND PLANNERS

DANBURY PUBLIC SCHOOLS
DANBURY HIGH SCHOOL
PARTIAL WINDOW / DOOR REPLACEMENT AND ABATEMENT

SECTION 00201

RFI FORM

B10 RFI - 12

CONTRACTOR'S REQUEST FOR INFORMATION NO. 12
NO: _____

OWNER'S RFI

NAME OF PROJECT: DANBURY HIGH SCHOOL PARTIAL WINDOW/ DOOR REPLACEMENT
AND ABATEMENT PROJECT

NAME OF OWNER: CITY OF DANBURY

DATE: 12/29/11

A/E PROJECT NO: 11029.00

FULLER DANGELO PC ARCHITECTS AND PLANNERS

45 KNOLLWOOD ROAD

ELMSFORD, NEW YORK 10523

TEL: 914.592.4444 FAX: 914.592.1717

FROM (CO. NAME): CHERRY HILL GLASS

CONTACT NAME: JULIE GOODMAN

SUBJECT: DOOR SCHEDULE

DISCIPLINE/TRADE: WINDOWS & DOORS BLDG PACKAGE ONE

DWG./SPEC. REFERENCE: A-750

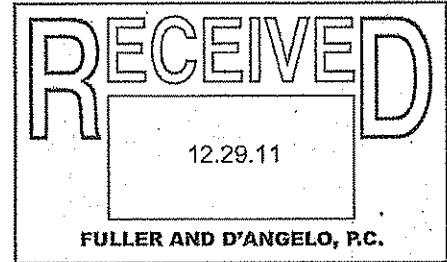

QUESTION:

- FIELD CONDITION PLEASE CONFIRM THAT WHERE A NOTE 2
- DRAWING/SPEC IS SHOW FRAME IS TO BE PAINTED.
- DISCREPANCY WHERE A NOTE 2 AND 4 ARE SHOW NOTE.
- OWNER CHANGE 2 SHOULD BE DELETED
- CLARIFICATION _____
- CONTRACTOR'S SUGGESTION (IF APPLICABLE): _____

ANSWER
CONFIRMED FOR DRAWINGS A-750 AND A-751

ARCHITECT'S SIGNATURE: [Signature]
DATE: 01.02.12

Note: review and any responses to this request for information by the architect/engineer is strictly for design intent only and does not constitute acknowledgement or acceptance of any cost or schedule implications unless specifically presented by the contractor. By submission of this request for information, the contractor assumes all responsibility in the absence of an approved change order or work directive.

END OF SECTION

FULLER AND D'ANGELO, P.C.
ARCHITECTS AND PLANNERS

DANBURY PUBLIC SCHOOLS
DANBURY HIGH SCHOOL
PARTIAL WINDOW / DOOR REPLACEMENT AND ABATEMENT

SECTION 00201

RFI FORM

BID RFI - 13
OWNER'S RFI

CONTRACTOR'S REQUEST FOR INFORMATION NO. 13
NO: _____

NAME OF PROJECT: DANBURY HIGH SCHOOL PARTIAL WINDOW/ DOOR REPLACEMENT
AND ABATEMENT PROJECT

NAME OF OWNER: CITY OF DANBURY

DATE: 1/3/12

A/E PROJECT NO: 11029.00

FULLER DANGELO PC ARCHITECTS AND PLANNERS

45 KNOLLWOOD ROAD

ELMSFORD, NEW YORK 10523

TEL: 914.592.4444 FAX: 914.592.1717

FROM (CO. NAME): CHEMUN HILL GLASS

CONTACT NAME: JULIE GORNWATER

SUBJECT: SCOPE

DISCIPLINE/TRADE: WINDOWS & DOORS BID PACKAGE ONE

DWG./SPEC. REFERENCE: A-742 / DETAIL 66

QUESTION:

FIELD CONDITION PLEASE CONFIRM THAT THE DEMO

DRAWING/SPEC CONTRACTOR IS RESPONSIBLE FOR

DISCREPANCY CLEANING THE EXISTING LUMESTONE

OWNER CHANGE _____

CLARIFICATION _____

CONTRACTOR'S SUGGESTION (IF APPLICABLE): _____

THE WINDOW CONTRACTOR IS ANSWER
RESPONSIBLE FOR THIS WORK SCOPE.

ARCHITECT'S SIGNATURE: [Signature]

DATE: 01.04.12

Note: review and any responses to this request for information by the architect/engineer is strictly for design intent only and does not constitute acknowledgement or acceptance of any cost or schedule implications unless specifically presented by the contractor. By submission of this request for information, the contractor assumes all responsibility in the absence of an approved change order or work directive..

END OF SECTION

FULLER AND D'ANGELO, P.C.
ARCHITECTS AND PLANNERS

DANBURY PUBLIC SCHOOL
DANBURY HIGH SCHOOL
PARTIAL WINDOW / DOOR REPLACEMENT AND ABATEMENT

SECTION 00201

RFI FORM

BID RFI - 14

CONTRACTOR'S REQUEST FOR INFORMATION NO. 1
NO: _____

OWNER'S RFI

PAF

1.1

NAME OF PROJECT: DANBURY HIGH SCHOOL PARTIAL WINDOW/ DOOR REPLACEMENT
AND ABATEMENT PROJECT

NAME OF OWNER: CITY OF DANBURY

DATE: 1/4/12

A/E PROJECT NO: 11029.00

FULLER DANGELO PC ARCHITECTS AND PLANNERS

45 KNOLLWOOD ROAD

ELMSFORD, NEW YORK 10523

TEL: 914.592.4444 FAX: 914.592.1717

FROM (CO. NAME): ARCHITECTURAL WINDOW

CONTACT NAME: DAVID LANG

SUBJECT: COLUMN AT WINDOW W-40

DISCIPLINE/TRADE: WINDOWS

DWG./SPEC. REFERENCE: A-731 W-40

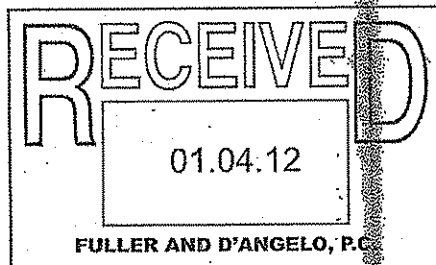

QUESTION:

FIELD CONDITION CONFIRM 5" X 4 1/2" COLUMN. IS IT EXIST'G?

DRAWING/SPEC DOES COLUMN OCCURE BETWEEN WINDOW
FRAMES?

DISCREPANCY

OWNER CHANGE

CLARIFICATION

CONTRACTOR'S SUGGESTION (IF APPLICABLE):

COLUMN IS EXISTING. ANSWER:

YES, COLUMN OCCURS BETWEEN WINDOW FRAMES.

ARCHITECT'S SIGNATURE: [Signature]

DATE: 01.04.12

Note: review and any responses to this request for information by the architect/engineer is strictly for design intent only and does not constitute acknowledgement or acceptance of any cost or schedule implications unless specifically presented by the contractor. By submission of this request for information the contractor assumes all responsibility in the absence of an approved change order or work directive.

PA

PA

END OF SECTION

FULLER AND D'ANGELO, P.C.
ARCHITECTS AND PLANNERS

DANBURY PUBLIC SCHOOLS
DANBURY HIGH SCHOOL
PARTIAL WINDOW / DOOR REPLACEMENT AND ABATEMENT

SECTION 00201

RFI FORM

BID RFI-15
OWNER'S RFI

CONTRACTOR'S REQUEST FOR INFORMATION NO. 1

~~NO. 11111~~

NAME OF PROJECT: DANBURY HIGH SCHOOL PARTIAL WINDOW/ DOOR REPLACEMENT AND ABATEMENT PROJECT

NAME OF OWNER: CITY OF DANBURY

DATE: _____

A/E PROJECT NO: 11029.00

FULLER DANGELO PC ARCHITECTS AND PLANNERS

45 KNOLLWOOD ROAD

ELMSFORD, NEW YORK 10523

TEL: 914.592.4444 FAX: 914.592.1717

FROM (CO. NAME): TCM

CONTACT NAME: _____

SUBJECT: _____

DISCIPLINE/TRADE: _____

DWG./SPEC. REFERENCE: _____

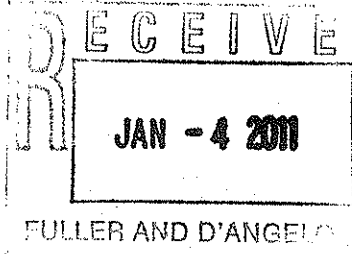

QUESTION:

FIELD CONDITION

SEE ATTACHED (2 PAGES)

DRAWING/SPEC

DISCREPANCY

OWNER CHANGE

CLARIFICATION

CONTRACTOR'S SUGGESTION (IF APPLICABLE): _____

ANSWER

ARCHITECT'S SIGNATURE: _____

DATE: _____

Note: review and any responses to this request for information by the architect/engineer is strictly for design intent only and does not constitute acknowledgement or acceptance of any cost or schedule implications unless specifically presented by the contractor. By submission of this request for information the contractor assumes all responsibility in the absence of an approved change order or work directive.

END OF SECTION

FULLER AND D'ANGELO PC
ARCHITECTS AND PLANNERS

City of Danbury
Danbury High School Partial Window/Door Replacement and Abatement
City Project No. 10-54
State Project No. 034-0137 EC
Bid No. 09-11-12-01

Questions / Answers

1/5/12

1. The specifications do not state the category that is required for CT DAS prequalification. Please confirm that the category for Bid Package #2 is *Asbestos Removal*.
 - a. Contractor to contact Connecticut DAS for clarification.
2. Please confirm that CT DAS documents only need to be submitted if our bid exceeds \$500,000.
 - a. Correct.
3. Are bidders to stipulate their intended Disposal facilities with the bid submittal for the Asbestos/PCB waste?
 - a. No.
4. Has EPA granted their approval of the performance based disposal?
 - a. The EPA has said approval is not required.
5. What is the anticipated Notice to Proceed date?
 - a. Notice to proceed will be issued after the contract has been executed. Construction cannot start until June 26, 2012.
6. Who will be responsible for confirmatory sampling of the surrounding building materials?
 - a. Since this project is using performance-based disposal, limited sampling (if any) will be performed. Any sampling performed will be the responsibility of the City.
7. Being that there are 2 separate bid packages, who will be responsible for site security?
 - a. Each contractor will be responsible for site security based on the locations of their work.



TMC ENVIRONMENTAL
Challenge us. Count on us.

January 4, 2012

Mr. Farid L. Khouri
City of Danbury
155 Deer Hill Avenue
Danbury, CT 06810

Re: Partial Window/Door Replacement and Abatement
City Project No. 10-54 / Bid No. 09-11-12-01

Dear Mr. Khouri,

Upon review of the, TMC Environmental (TMC) is submitting a request for clarification on the following items:

1. The specifications do not state the category that is required for CT DAS prequalification. Please confirm that the category for Bid Package #2 is *Asbestos Removal*.
2. Please confirm that CT DAS documents only need to be submitted if our bid exceeds \$500,000.
3. Are bidders to stipulate their intended Disposal facilities with the bid submittal for the Asbestos/PCB waste?
4. Has EPA granted their approval of the performance based disposal?
5. What is the anticipated Notice to Proceed Date?
6. Who will be responsible for confirmatory sampling of the surrounding building materials?
7. Being that there are 2 separate bid packages, who will be responsible for site security?

TMC looks forward to your response.

Thank you,
Angie Coe
TMC Environmental
Proposal & Contract Manager
Direct: 508-966-6008
Email: acoe@tmcenvironmental.com

ND	JEF	JD	MM	RECEIVED			
FULLER AND D'ANGELO, P.C. ARCHITECTS AND PLANNERS							
JAN 4 2012							
DC	VC	FD	ML	JM	WJM	CLS	SZ



JANUARY 3, 2012

MINUTES OF MEETING - PRE-BID

DATE: DECEMBER 28, 2012
RE: DANBURY SCHOOL DISTRICT
DANBURY HIGH SHOOOL
DANBURY HIGH WINDOW & DOOR REPLAFEMENT
F&D PROJECT NO: 11029.00

PRESENT: F. KHOURI - CITY OF DANBURY
T. HUGHES - CITY OF DANBURY
D. PETROVICH - CITY OF DANBURY
R. PALANZO - CITY OF DANBURY
D. REISERT - CITY OF DANBURY
C. VOLPE - CITY OF DANBURY PURCHASING
M. ZUBAREV - BROOKS ENVIRONMENTAL
D. ALBACH - HONEYWELL
J.FREEMAN - HONEYWELL
F. DIFATO - FULLER AND D'ANGELO, PC, ARCHITECTS

**CONTRACTORS - PER ATTACHED SIGN-IN SHEET
(MINUTES TO BE DISTRIBUTED VIA CITY OF DANBURY)**

THE FOLLOWING WAS DISCUSSED.

1.1 INTRODUCTION:

- A. F. Khouri introduced all City of Danbury personnel present.
- B. Energy Performance Contractor/Construction Manager: Honeywell
- C. Environmental: Brooks Environmental
- D. Architect: Fuller and D'Angelo
1. Project Architect: Frank DiFato

1.2 BID DUE DATE: DATE AND PLACE.

- A. **Bids received until:** January 12, 2012 10:0 AM Local Time
Location: Danbury City Hall, Purchasing Agents Office
- B. Bid documents to be obtained directly through the City Purchasing Department for \$100/set (non-refundable).

1.3 SUMMARY OF PROJECT

- A. Two Prime Contract(s): Windows/Doors and Abatement. Window/Doors part of an overall Energy Performance Contract for the City.
- B. **Package No. 1**-Windows/Doors (will be assigned to Honeywell EPC/Construction Manager.) Refer to Appendix "B" of specifications for additional Honeywell requirements.
- C. **Package No. 2**-Abatement and removal of windows.
- D. **Alferenate 1: Area E** Building Addition as shown on the documents.
- E. **Alferenate 2: Area F** as shown on the documents.

RE: Minutes of Pre Bid Meeting - 12/28/11
Danbury HS Windows and Doors

- F. **Alternate 3:** Substitute **FRP door(s)** for where new aluminum doors(s) are specified.
- G. Allowance: (For Window Contractor)
 - 1. \$160,000 for purchase and delivery of materials and hardware for new roller manual type solar shades. **Costs for installation Labor**, should be included in base bid.

1.4 PROPOSAL FORMS

- A. Refer to information to bidders for items required along with proposal form and Section 00100 for Bid Form.

1.5 ADDENDUM

- A. Any required interpretations will be handled by Addendum and distributed by e-mail no later than 3 days prior to bid opening date.

1.6 BIDDING REQUIREMENTS

- A. RFI form included in documents. Section 00201 Please use it for any RFI's.
- B. RFI's must be submitted in writing at least five (5) days prior to the bid opening. (This will be confirmed by Addendum).
- C. **Questions to be sent** to Mr. C. Volpe, City of Danbury Purchasing Dept. and to Fuller and D'Angelo, PC, Architects and Planners.
- D. State Assisted Contracts: All State regulations must be followed.

1.7 GENERAL CONDITIONS:

- A. Project is tax exempt. City of Danbury can issue certificate number.
- B. Bid Bond Required **5%** of Bid amount including alternates.
- C. Performance, Labor and Material Bond Requirement **100%** of Bid amount including Alternates.
- D. Bids in excess of \$500,000 require submission of DAS documents.
- E. Specific insurance requirements in the Contract Documents.

1.8 USE OF PREMISE

- A. Classes not in session but building **will be** occupied during construction. Restrict operations to work areas and site areas as indicated. Maintain building egress at all times.
- B. Co-ordinate all access on site and building with Owner.

1.9 SUMMARY OF WORK:

- A. Start/Finish Dates:
 - 1. Submittals completed by February 15th, 2012 (this will be confirmed by Addendum).
 - 2. Windows and Doors delivery date of March 23, 2012 is incorrect. May 23, 2012 is the new delivery date. (This will be confirmed by Addendum.)
 - 3. Start Construction June 26th, 2012 (ten day abatement notice will be June 7 to Jun 20, 2012)
 - 4. Completion: August 26th, 2012 (Teachers return to school).
 - 5. No abatement can take place while building is occupied by students or teachers.
- B. Time Limit:
 - 1. The City will not pay for any overtime or weekend work that may be required.

RE: Minutes of Pre Bid Meeting - 12/28/11
Danbury HS Windows and Doors

1.10 CO-ORDINATION:

- A. Window Contractor will follow Abatement Contractor. See suggested schedules and phasing on drawings. Abatement Contractor cannot be more than 40 window units ahead of Window Contractor.
- B. Multiple crews and shifts will be required – refer to detailed scheduled on Drawing S-1.

1.11 CUTTING AND PATCHING:

- A. Each Contractor is responsible for his cutting and patching

1.12 PAYMENTS:

- A. Refer to Section 01200. Payments for package No. 1 will be through Honeywell.

1.13 CONTRACTOR TEMPORARY FACILITIES: REFER TO SECTION 01500

- A. Mobile phone required on site.
- B. Temporary fence required at Temporary entrance and dumpsters.
- C. Dust protection required.
- D. Protection of existing floors in corridors, classrooms, gymnasium, etc.
- E. Temporary power for any specialty equipment, i.e. welding by Contractor.
- F. Waste containers by Contractor.
- G. Temporary weather barriers required by both prime Contractors. Refer to the documents. Removals of temporary barriers by Window Contractor.
- H. Project sign is the responsibility of the Window Contractor.

1.14 SUBSTITUTIONS: REFER TO SECTION 01600

- A. Form included in specifications. Contractor's responsibility for burden of proof.

1.15 PREVAILING WAGES:

- A. Prevailing wage rates must be followed - Attached in Appendix A of the specifications.
- B. Require certified payroll and OSHA ID and certification for all payment requisitions.

1.16 QUALITY CONTROL

- A. Refer to section 01400

1.17 GENERAL DISCUSSION:

- A. Existing security system in building. Access needs to be coordinated with the Owner.

RE: Minutes of Pre Bid Meeting - 12/28/11
Danbury HS Windows and Doors

At the conclusion of meeting a walk thru was conducted for those bidders wishing to avail themselves.

In the event of a discrepancy between these minutes and the contract documents the contract documents shall prevail unless modified by addendum.

It is assumed that these Minutes are a true summary of the meeting. Any corrections or omissions should be brought to the attention of the writer. If not, they will be considered substantially correct.

Submitted by



Frank DiFato, RA

JFF/clb

cc: J. Fuller, Jr., F&D
M. Granville, Brooks

2064

CITY OF DANBURY, CT
Pre-Bid Conference Sign-In Sheet

Bid #09-11-12-01 "Partial Window / Door Replacement and Abatement at the Danbury High School" DATE: Wed., December 28, 2011, 10:00 AM

NAME	COMPANY / ADDRESS	PHONE NUMBER	FAX NUMBER	E-MAIL ADDRESS
Charles Volpe ✓	City of Danbury Purchasing Dept	203-797-4571	203-796-1527	e.volpe@dabury-ct.gov
MIKE ZUBAREV ✓	BROOKS ENVIRONMENTAL	203 853 9792	203 853 0273	BROOKS@BROOKS BROOKS@BROOKS.COM
Dylan Albach ✓	Honeywell	551-580-5297	201 621 4464	dylan.albach@Honeywell.com
JAY MRAZ	CITELUX ALL GLASS	203-483-1717	203-483-9657	JMRAZ@CITELUXALLGLASS.COM
Ed Stack	Oscar's Abatement	860-296-7450	860-296-7417	estack@oscarabatement.com
Jay Rainville	MS Construction	888-286-3760	203-568-0334	Mr.rainville@msmail.com
Bob Gomez	Binswanger Glass Bristol, CT	860-583-1345	860-583-6062	rgomez@binswangerglass.com
Farid Khouri ✓	City	203 797 4641		F.Khouri@Danbury-ct.gov
DAN PETRONICH ✓	CITY	203 797 4641		D.Petronich@Danbury-ct.gov
DAN ROBERT ✓	C.I.O.D.	203-796-8069		D.ROBERT@DANBURY-CT.GOV

3064

CITY OF DANBURY, CT
Pre-Bid Conference Sign-In Sheet

Bid #09-11-12-01 "Partial Window / Door Replacement and Abatement at the Danbury High School" DATE: Wed., December 28, 2011, 10:00 AM

NAME	COMPANY / ADDRESS	PHONE NUMBER	FAX NUMBER	E-MAIL ADDRESS
DAVID LABIG	ARCHITECTURAL WINDOW MANUF CORP.	201-939-2200	201-939-2201	DAVIDL@ARCHITECTURALWINDOW.COM
DRACI KAY BENINARO	EXCER INDUSTRIAL WINDOW	973-835-6100	973-835-6101	EXCER@INDUSTRIALWINDOW.COM
FRANK DIFATO	INDUSTRIAL WINDOWS 5500 STATE RD BRIDGEPLIFFMANAOK	914-983-1800	914-983-6028	RAREINDUSTRIALWINDOW.COM
ROY BLUM	FULLER E DANGER ARCHITECTS GREENBARD ENT. INC	914-592-4144	914-592-1717	FRANK@FULLERDANGELO.COM
DIM FREEMAN	HONEYWELL	201-315-2862	973 604-4184	ROYBLUM@GREENBARDENTERPRISELLC.COM
			845-818-3869	Dim.Freeman@honeywell.com

