



## City of Norwich

Department of Finance – Purchasing Agent  
100 Broadway, Room No. 105  
Norwich, CT 06360

Phone: (860)823-3706  
Fax: (860)823-3812  
E-mail: [whathaway@cityofnorwich.org](mailto:whathaway@cityofnorwich.org)

### INVITATION FOR BIDS

**Bid No.:** 7576

**Due Date and Time:** March 28, 2018 at 2:00 P.M.

**Title:** 2018 ADA Sidewalk Ramps Project

**Special Instructions:**

The following information must appear in the lower left hand corner of the envelope:

Sealed Bid No.: 7576

Not to be opened until March 28, 2018 at 2:00 P.M.

**Return Bids to:**

William R. Hathaway, Purchasing Agent  
City of Norwich  
100 Broadway, Room 105  
Norwich, CT 06360-4431

## TABLE OF CONTENTS

Bid No. 7576

	No. of Pages
<b>Introductory Information</b>	
Title Page	1
Table of Contents	1
Invitation for Bids	1
Acknowledgement of Receipt of Bid Documents	1
<b>Bidding Requirements</b>	
Instructions to Bidders	8
General Conditions	10
City of Norwich Standard Bid and Contract Terms and Conditions	5
Supplementary CDBG Provisions	4
Federal Contract Provisions	49
Davis-Bacon Wage Rates	9
<b>Contract Forms</b>	
City of Norwich – Contract for Services	9
Performance and Payment Bonds	4
<b>Specifications</b>	
Project Description	2
Site Construction Notes	1
Technical Specifications	34
<b>Bid Forms</b>	
Bid Form	2
Bid Bond Form	3
Site Visit Verification form	1
Non-Collusion Affidavit of the Prime Bidder	1
Non-Collusion Affidavit of the Sub-Contractor	1
Statement of Bidder’s Qualifications	2
Affirmative Action/Equal Opportunity Employment Policy Statement	2
Certificate of Bidder Regarding Equal Employment Opportunity	1
Certification of Non-Segregated Facilities	1

**CITY OF NORWICH**  
**Invitation for Bids**

**Bid No. 7576**

Sealed bids for the **2018 ADA Sidewalk Ramps Project** will be received in the office of the Purchasing Agent, City of Norwich, 100 Broadway, Room 105, Norwich, CT 06360-4431, until 2:00 P.M. prevailing time on **March 28, 2018**. All bids will then be publicly opened and read aloud.

The bid documents may be downloaded from the following websites:

City of Norwich	<a href="http://www.norwichct.org">http://www.norwichct.org</a>
State of Connecticut	<a href="http://das.ct.gov">http://das.ct.gov</a>

Addenda, if any, will be posted on the websites listed above. All bidders, prior to submitting their bids, should check the websites to ensure they have received all issued addenda.

Requests for information (RFIs) must be submitted in writing no later than 12:00 P.M. on **March 16, 2018**. RFIs must be sent to William R. Hathaway, Purchasing Agent via fax to (860)823-3812, e-mail to [whathaway@cityofnorwich.org](mailto:whathaway@cityofnorwich.org) or U.S. Postal Service to City Hall, 100 Broadway, Room 105, Norwich, CT 06360-4431.

Bid surety in the form of a bid bond, certified or bank check in the amount equal to five per cent (5%) of the total bid amount is required at the time of bid.

The City of Norwich reserves the right to reject and all bids, in whole or in part, to waive minor irregularities in the bidding and to award the bid to other than the low bidder if deemed in the best interest of the City of Norwich.

This project is funded with Community Development Block Grant funds and is subject to Davis-Bacon Wage Rates.

The City of Norwich is an Equal Opportunity/Affirmative Action Employer. Minority/Women's Business Enterprises are encouraged to apply. This contract is subject to state set-aside and contract compliance requirements.

William R. Hathaway  
Purchasing Agent



**RETURN THIS FORM IMMEDIATELY**

**City of Norwich, CT  
Acknowledgement of Receipt of Bid Documents**

**Bid No.:** 7576  
**Title:** 2018 ADA Sidewalk Ramps

Please take a moment to acknowledge receipt of the attached documents. Your compliance with this request will help the City of Norwich to maintain proper follow-up procedures and will ensure that your firm will receive any addendum that may be issued.

Date Issued: 03/08/2018  
Date Documents Received: \_\_\_\_\_/\_\_\_\_\_/\_\_\_\_\_  
Do you plan to submit a response? \_\_\_\_\_ Yes \_\_\_\_\_ No

Company Name: \_\_\_\_\_

Address: \_\_\_\_\_  
\_\_\_\_\_

Telephone: \_\_\_\_\_ Fax: \_\_\_\_\_

E-mail Address: \_\_\_\_\_

Received by: \_\_\_\_\_

**Note: Faxed or e-mailed acknowledgements are requested.**

**Fax No.:** (860)823-3812

**E-mail:** [whathaway@cityofnorwich.org](mailto:whathaway@cityofnorwich.org)

**Fax or e-mail this sheet only. A cover sheet is not required.**

**DO NOT FAX OR E-MAIL YOUR RESPONSE TO THIS RFP**

**INSTRUCTIONS TO BIDDERS  
CITY OF NORWICH, CT 06360**

**Bid Number: 7576**

The following instructions and specifications shall be observed by all bidders:

**1. Time and Place of Bid Opening**

Bids will be received on **March 28, 2018 at 2:00 P.M.** at the Purchasing Agent's Office, 100 Broadway, Room 105, Norwich, CT 06360. Any bid received after the time and date of bid opening shall not be accepted.

**2. Availability of Bid Documents**

Bidders are advised that all bid documents relative to this project are only available online at the following web addresses:

<http://www.norwichct.org>

<http://das.ct.gov>

**3. Bid Addenda**

If additional information becomes available or changes are made to the bid documents, an addendum will be issued not later than 3 days prior to the bid opening date. All addenda shall become part of the Contract Documents.

All addenda will be sent via e-mail to those bidders that complete and return the Receipt Acknowledgement for to the Purchasing Department. It is incumbent on the bidder to ensure that it has received all issued addenda by checking the websites listed above. Failure of any bidder to receive any such addendum shall not relieve it of the obligations under its bid as submitted. Certification of receipt of addenda shall be made by the bidder on the proposal.

Notice of any addendum will be posted on the following websites:

<http://www.norwichct.org>

<http://das.ct.gov>

**4. Bid Surety Requirements**

A Bid Surety in the amount of 5 percent (5%) of the total amount bid is required at the time of bid. Bid Surety shall be in the form of a Bid Bond provided by a surety licensed to do business in the State of Connecticut, Certified Check or Bank Check.

**FAILURE OF A BIDDER TO PROVIDE THE REQUIRED BID SURETY SHALL RESULT IN REJECTION OF ITS BID.**

**5. Bid Instructions**

Bids must be enclosed in a sealed envelope, addressed to the City of Norwich and clearly identified with the bid number and name as shown on the face of these bid documents.

Bids must be made on the attached forms with complete information as requested of the bid forms. Bids submitted on forms other than those included within this document shall not be considered.

**6. Examination of Site Conditions**

Bidders must satisfy themselves by personal examination of the site and location of the proposed work as to the actual conditions and requirements of the work and inform themselves fully of the conditions relating to the construction and labor under which the work will be performed. No claim because of lack of knowledge by the contractor regarding the site, the proposed work or content of the specifications and drawings will be allowed. At the date established for the opening of bids, it will be presumed that each bidder has made an examination of the location and site of the work to be done under this contract and has satisfied itself as to the actual conditions and requirements.

**7. Prevailing Wage Rates**

This project shall be subject to prevailing wages rates issued by the United States Department of Labor, which are included within these specifications. Each bidder shall include any additional costs associated with prevailing wage rates as a part of its bid.

**8. Sales and Use Tax**

Bidders are reminded that the Connecticut State Sales and Use Tax and associated Federal taxes are not applicable under this contract, and therefore these taxes are not to be included in the bid price(s).

Under the terms of Connecticut Agencies Regulations §12-426-18, Contractors and Subcontractors, the contractor may purchase materials and supplies as are to be installed or placed in projects being performed under these contracts and will remain in such projects after completion, including tangible personal property that remains tangible personal property after its installation or placement, without payment of the tax and shall not charge any such exempt organization or agency any sales or use tax thereon.

**9. Definitions**

For the purposes of these documents:

The word "City" means the City of Norwich, CT.

The words "City Manager" mean the City Manager of the City of Norwich, CT.

The word "Director" means the Director of Public Works for the City of Norwich, CT.

The word "Engineer" refers to the City Engineer of the City of Norwich, CT.

The word "Bidder" refers to the party or parties submitting a bid to perform the work to be done or materials to be furnished under the Contract; the legal representatives of such party or parties.

The word "Contractor" refers to the party or parties contracting to perform the work to be done or materials to be furnished under the Contract; the legal representatives of such party or parties.

**10. Subcontractors**

The Contractor shall not sublet any portion of the work without written permission from the City. In no case may it sublet more than forty-nine percent (49%) of the monetary value of the Contract (i.e. the major units of the work of the Contract shall be performed by the Contractor). If the Contractor sublets any part of the work, this does not relieve it or the bonding company of liabilities and obligations to the City. There is no contractual relationship between any subcontractor and the City; the Engineer deals only with the Contractor. For the purposes of this section, costs attributable directly to equipment purchase costs shall neither be attributable to the Contractor nor the subcontractor.

The Contractor must not assign or dispose of his Contract in any way without the written consent of the Engineer in conjunction with that of the City Manager. Disposal must be for cause only.

**11. Project Location**

The work for this project will be performed at the locations identified in the specification..

**12. Intent**

The intent of these specifications is to obtain a Contractor that will furnish all labor, supervision, tools, materials and equipment necessary to install curbing, sidewalks and other associated work on the designated street(s) within Norwich, CT as detailed within these specifications.

**13. Work Schedule**

The Contractor shall contact the Engineering Department at (860)823-3798 prior to the start of any work associated with this Contract.

No work will be performed at night or on Sundays or legal holidays, except in case of emergency and only to the extent to make the work site safe. The normal work day shall be considered as any eight (8) hour period falling between 7:00 A.M. and 4:00 P.M., Monday through Friday. Special clearance will be required for work outside these times.

All work under this Contract is to be completed in accordance with the schedule requirements contained in the Site Construction Notes.

**14. Evaluation of Prices Submitted**

Bids will be compared on the basis of the estimated quantities times the unit or lump sum prices stated in Bid. In the event of a discrepancy between prices written in word and figures, the prices written in words shall govern. In the event of a discrepancy between (1) the Total amount of lump sum line items and/or unit prices as recorded on the bid form by the bidder and (2) the Total amount of the bids as recorded on the bid form by the bidder and tabulated by the Purchasing Agent, the latter shall prevail.

It is the intent of the City to make award to the lowest, responsible qualified bidder (Ref. C. G. S. §4a-59).

**15. Engineer's Estimate of the Work**

The Engineer's estimate of the work and materials by which the bids will be compared are as shown in the Bid and are solely for the purpose of comparing bids received and are approximate only and are not guaranteed.

**16. Contractor Qualifications**

Bidders, if requested, must be able to present satisfactory evidence that they are capable and fully prepared with necessary capital, personnel, materials and equipment to do the work to be contracted under this proposal.

Firms submitting bids must be prequalified by the State of Connecticut Department of Administrative Services (DAS) to perform concrete and/or site work, and shall include with their bid a copy of a current certificate as issued by DAS. Additionally, any subcontractor performing any work on this contract must be pre-qualified with DAS to perform said services and the firms submitting the bid shall include with their bid a copy of the current certificate as issued by DAS for each subcontractor.

Interested bidders are advised that award of contracts are limited to entities registered to do business with the federal government through the System for Award Management (SAM). For further information, please visit the Government Contract Registration Center online via the following link:

<https://www.sam.gov>

**17. Certificate in Good Standing**

Any corporation whose bid is being considered for acceptance by the City may be required, if requested, to provide a "Certificate of Good Standing" from the Office of the Secretary of State for Connecticut.

**18. Acceptance/Rejection of Bids**

The City may reject bids which are incomplete, conditional, obscure, contain additions not called for, erasures or corrections not initialed, or which contain alterations or irregularities of any kind. The City may rightfully waive informalities. The Purchasing Agent reserves the right to reject any or all bids; or the bids for any one or more commodities or contractual services included in any or all bids; and, unless otherwise specified, to buy any part or the whole from one or more bidders when it is in the best interest of the City to do so. The City also reserves the right to reject any or all bids, or to award any bid to other than the low bidder if it is deemed in the best interest of the City to do so.

Determination of the best interest of the City shall include consideration of active or pending civil litigation between the City and any firm (or its subcontractors or suppliers) submitting a bid to the City.

**19. Withdrawal of Bid Submitted**

Any bid may be withdrawn prior to the designated date and time for receipt of bids. Bids may be withdrawn ninety (90) days after the bid opening if no award has been made by the City. If the City does not award a contract within ninety (90) days after opening of bids, all bids will be



null and void, except this time may be extended on mutual agreement of the City and the lowest qualified vendor, as determined by the City.

**20. Contract Execution**

The firm(s) whose bid(s) has/have been accepted by the City will be required to furnish all insurance certificates in the amounts specified, within 5 days from the date of the notice of award. The firm(s) will also be required to furnish all performance and payment bonds to the City prior to contract signing.

The firm(s) whose bid is accepted will be required to execute a contract, in substantially the form included in the bid documents, on a date and time mutually agreed to by all parties. Once the contract is executed, the contractor(s) will be issued a Notice to Proceed.

Contracts valued at less than \$25,000.00 may be executed directly via the issuance of a purchase order, at the discretion of the City.

**21. Inclusion of Contract Provisions**

The bidders' attention is directed to the form of this agreement, which, in addition to the Instructions to Bidders includes the bid proposal forms, general provisions, special provisions, federal/state provisions, specifications, measurement and payment provisions, contract drawings (if applicable) and standard detail drawings.

**22. Contract Related Documents**

The Contractor shall provide the bonds and Certificates of Insurance to the Purchasing Agent. In case of failure or refusal on the part of the bidder to enter into a contract or to furnish the required bonds and/or required certificates of insurance within the set time periods, the bidder shall forfeit to the City of Norwich such part of the bid bond as shall be equal to the difference between the total bid of the defaulting bidder and the total bid of the person or persons with whom the contract is finally executed.

**23. Acceptance of Alternate Materials or Methods**

When alternate bids are asked for, the City at time of the awarding or prior to signing of the contract, through its Engineer, will select which type of material or which method of construction will be used.

**24. Indemnification**

The Contractor shall indemnify and save harmless the City and its officers, agents, servants and employees, from and against any and all claims, demands, suits, proceedings, liabilities, judgments, awards, losses, damages, costs and expenses, including attorneys' fees, on account of bodily injury, sickness, disease or death sustained by any person or persons or injury or damage to or destruction of any property, directly or indirectly arising out of, relating to or in connection with the work, whether or not due to or claimed to be due in whole or in part to the active, passive or concurrent negligence or fault of the Contractor, its officers, agents, servants or employees, any of its subcontractors, the City or any of their respective officers, agents, servants or employees and/or any other person or persons, and whether or not such claims, demands, suits or proceedings are just, unjust, groundless, false or fraudulent; and the Contractor shall and does hereby assume and agrees to pay for the defense of all such claims, demands, suits and proceedings, provided, however, that the Contractor shall not be required to indemnify the City, its officers, agents, servants, or employees, against any such damages occasioned solely by acts or omissions of the City other than supervisory acts or omissions of the City in the work.

## **25. Equal Opportunity Employment and Affirmative Action**

The successful contractor shall comply in all aspects with the Equal Employment Opportunity Act as well as the provision of Title VI of the Civil Rights Act of 1964 and all amendments thereto. Each contractor with 15 or more employees shall be required to have an Affirmative Action Plan which declares that the contractor does not discriminate on the basis of race, color, religion, gender, national origin or age and which specifies the goals and target dates to assure the implementation of equal opportunity employment. Each contractor with fewer than 15 employees shall be required to have a written equal opportunity employment policy statement declaring that it does not discriminate on the basis of race, color, religion, gender, national origin or age. Findings of noncompliance with applicable State and Federal equal opportunity laws and regulations could be sufficient reason for revocation or cancellation of this contract. The contract is also subject to contract compliance requirements mandated by Connecticut General Statutes §§ 4a-60 and 40a-60a.

## **26. Contractor's and Subcontractors' Insurance**

The Contractor shall procure and maintain insurance of the types specified below, and to the limits for this insurance specified in the Standard Bid and Contract Terms and Conditions and the City of Norwich Code of Ordinances, Article IV., §2-71. All insurance shall be obtained from companies satisfactory to the City.

Insurance shall be in such forms as will protect the Contractor from all claims and liability for damages for bodily and personal injury, including accidental death, and for property damage, which may arise from operations under the Contract, whether such operations be by itself, its subcontractors, or by anyone directly or indirectly employed or engaged by it.

The following types of insurance shall be provided before starting and until final completion and acceptance of the Work and expiration of the guarantee period provided for in the Agreement.

- a. Workmen's Compensation and Employer's Liability Insurance.
- b. Bodily Injury Insurance for operations and completed operations and Contractor's Protective Bodily Injury Insurance.
- c. Property Damage Insurance for operations and completed operations and Contractor's Protective Property Damage Insurance, each including coverage for injury to or destruction of wires or pipes and similar property and appurtenant apparatus and the collapse of or structural injury to any building or structure except those on which work under the Contract is being done. Blasting and explosion coverage shall be obtained if there is a need for blasting under the Contract, and no blasting shall be performed until such insurance has been secured.
- d. Bodily Injury Insurance covering the operation of all motor vehicles owned by the Contractor.
- e. Personal Injury Insurance to cover claims for personal injury and including claims brought by employees.
- f. Property Damage Insurance covering the operation of all motor vehicles owned by the Contractor.
- g. Insurance to cover bodily injuries and property damage resulting from the use of motor vehicles not owned by the Contractor, while such vehicles are being operated in connection with the prosecution of the work.

- h. Contractual Liability Insurance covering the liability assumed by the Contractor under the fifth paragraph of that subsection titled "Obligations and Liability of Contractor" of this Agreement.
- i. Owner's Protective Liability and Property Damage Insurance to protect the City and any Engineer against claims for Property damage and for bodily injuries, including accidental death, caused by the operations of the Contractor or its subcontractors on the Work. The policy shall indicate the City and any Engineer as the named insured. A copy of the policy shall be furnished to the City and a Certificate of Insurance shall be furnished to any Engineer.

All policies shall be so written that the City will be notified in writing of cancellation or restrictive amendment at least 30 days prior to the effective date of such cancellation or amendment.

Certificates from the Contractor's insurance carriers stating the coverages provided, the limits of liability, and expiration dates shall be filed in triplicate with the Engineer before operations are begun. Such certificates shall be on the form furnished by the Engineer.

Renewal certificates must be furnished by the Contractor prior to the expiration date of any of the initial insurances.

No insurance required or furnished hereunder shall in any way relieve the Contractor of or diminish any of its responsibilities, obligations and liabilities under the Contract.

## **27. Bond Requirements**

For all contracts in excess of \$25,000.00, the awarded contract shall provide the City with the following bonds in the minimum amounts specified herein.

- a. **Labor and Materials Bond** in the amount equal to 100% of the Total Proposal Price guaranteeing to the City payments for all labor, materials and equipment utilized in the completion of the work under this contract in the amount of the contract award.
- b. **Performance Bond** in the amount equal to 100% of the Total Proposal Price guaranteeing to the City the completion of the Contract.

All bonds shall be issued by a surety that is named in the current list of "Companies Holding Certificates of Authority as Acceptable Sureties on Federal Bonds and as Acceptable Reinsuring Companies" as published in Circular 570 (amended) issued by the U.S. Department of the Treasury, Bureau of the Fiscal Service, Surety Bond Section.

It is distinctly agreed and understood that any changes in the plans and/or specifications for this work, whether such changes decrease or increase the amount thereof, or the manner or time of payment, shall in no way annul, release or affect the liability and surety on the bond given by the contractor.

## **28. Safety**

All work done and all equipment used shall comply with all pertinent OSHA, Federal, State and local regulations, laws and ordinances affecting those employed and any affecting the conduct of the work.

Not later than thirty (30) after the date of contract award, the awarded contractor shall furnish proof to the Commissioner of the State of Connecticut Department of Labor that all employees

performing manual labor on or in such public project, pursuant to such contract, have completed the 10 hour OSHA Construction Safety and Health course, or in the case of telecommunications workers, have completed at least 10 hours of training in accordance with 29 CFR 1910.268.

The State of Connecticut and all political subdivisions have adopted a zero tolerance policy for workplace violence. In accordance with Executive Order No. 16 issued by Governor John G. Rowland, all contractors, subcontractors and vendors must comply with this policy.

**29. Personnel Requirements**

All work under this contract shall be performed by competent and proficient tradesmen employed by the contractor and under its supervision. Apprentices and helpers may be used, but only under the direct supervision of the job foreman.

**30. Subcontractors**

The Contractor shall not sublet any portion of the work without written permission from the City. In no case may it be more than forty-nine percent (49%) of the monetary value of the contract. The major units of the work shall be performed by the Contractor. If the Contractor sublets any part of the work, this does not relieve it or the bonding company of their liabilities and obligations to the City. There is no contractual relationship between any subcontractor and the City. The engineer deals only with the Contractor; subcontractors are recognized as employees of the Contractor.

The Contractor must not assign or dispose of its contract in any way without the consent of the engineer in conjunction with the City Manager. Disposal must be for cause.

**31. Freedom of Information**

All bids will be publicly opened and read and upon award shall be made available for public inspection, in accordance with the provisions of Connecticut General Statutes § 1-210, Freedom of Information. Copies of any information resulting from any bid opening are generally not available until a contract has been formally awarded.

**32. Non-Collusion**

The individual signing this bid hereby declares that no person or persons other than members of its organization are interested in this bid or in the contract proposed to be taken; that it is made without any connection to any other person or persons submitting a bid for the same work and is in all respects fair and without collusion or fraud; that no person acting on behalf of or employed by the City of Norwich is directly or indirectly interested in the supplies or work to which they relate or will receive any part of the profit or any commission therefrom in any manner which is unethical or contrary to the best interests of the City of Norwich.

**INDEX TO GENERAL CONDITIONS**

<b><u>ARTICLE</u></b>	<b><u>TITLE</u></b>
1.	DEFINITIONS
2.	BID FORM
3.	BID SECURITY
4.	WAGE RATES AND LABOR LAWS
5.	CONTRACTOR'S BOND AND INSURANCE
6.	NONRESIDENT CONTRACTOR BOND
7.	INDEMNITY OF CITY BY CONTRACTOR
8.	PERMITS, LICENSES AND LAWS
9.	RIGHT TO REJECT BIDS
10.	BIDDERS TO EXAMINE SPECS & VISIT WORK SITE
11.	REPRESENTATIONS OF CONTRACTOR
12.	COMPETENT HELP TO BE EMPLOYED
13.	PROHIBITING EMPLOYEE DISCRIMINATION BY CONTRACTOR
14.	SCOPE OF WORK
15.	MATERIALS
16.	SUBCONTRACTORS
17.	ASSIGNMENT
18.	SEPARATE CONTRACTS
19.	PARTIAL INVALIDITY
20.	LIGHTS, BARRIERS, FENCES, WATCHMEN AND INDEMNITY
21.	FIRE PRECAUTION
22.	"OR APPROVED EQUAL" CLAUSE
23.	TERMINATION FOR CONVENIENCE
24.	TITLE TO WORK
25.	TIME OF COMPLETION
26.	INSPECTION
27.	SPIRITOUS LIQUORS
28.	WORK CHANGES
29.	CLAIMS FOR EXTRA WORK
30.	DEFAULTS
31.	TAXES
32.	OCCUPATIONAL SAFETY AND HEALTH ACT OF 1970
33.	COMPLIANCE WITH NON-DISCRIMINATION
34.	WORK IN INCLEMENT WEATHER
35.	PROTECTION OF TREES
36.	ARCHEOLOGICAL FINDS
37.	BLASTING
38.	POWER AND WATER
39.	TOILET ACCOMMODATIONS
40.	CLEAN UP
41.	GENERAL GUARANTEE
42.	LIENS
43.	PAYMENTS
44.	PAYMENT TO SUBCONTRACTORS
45.	FINAL INSPECTION AND ACCEPTANCE
46.	FINAL PAYMENT
47.	CORRECTIONS
48.	INTERPRETATION OF DRAWINGS AND SPECS
49.	LOADING
50.	POLLUTION OF WATERS
51.	USE OF "HE", "HIS", OR "HIM"
52.	REFERENCE
53.	SURPLUS MATERIAL

**CITY OF NORWICH**  
**DEPARTMENT OF PUBLIC WORKS**  
**GENERAL CONDITIONS**

**1. DEFINITIONS**

- A. **City** - The City of the project is the City of Norwich acting by the Director of Public Works.
- B. **Contractor** - The term "contractor" as hereinafter used shall refer to the General Contractor for this work or his authorized representative.
- C. **City's Representative** - The term "City's Representative" as hereinafter used shall refer to any representative of the Department of Public Works who is appointed by the Department to supervise the work and shall extend to and include any engineer or inspector whom he shall designate to inspect, test, or oversee the work herein specified.
- D. **Department** - Whenever this term is used in these General Conditions, "Department" shall mean City of Norwich, Department of Public Works.
- E. **City** - Wherever the term "City" is used in these General Conditions, it shall mean the City of Norwich, the City of Norwich Department of Public Works.
- F. **Contract** - Wherever the term "Contract" is used in these General Conditions, it shall mean the actual bid form, specifications, drawings, General Conditions and formal purchase order issued to the successful bidder.

**2. BID FORM**

Attached to these specifications is a bid form which shall be used by the contractor submitting bids on this work.

Bids for this work shall be received at the Office of Purchasing Agent, City of Norwich, City Hall Building, at the time of the date designated on the bid forms, and will be publicly opened and read at the time and place, for this work. One copy of bid is for bidders.

Discrepancies between the indicated product of item unit and unit price and the correct product will be resolved in favor of the unit prices. Discrepancies between the indicated sum of any column of figures and the correct sum thereof will be resolved in favor of the correct sum. Discrepancies between words and figures will be resolved in favor of the words.

**3. BID SECURITY**

Each contractor submitting a bid shall accompany it with bid Surety in the form of cash, certified check or bid bond equal to 5% of the bid. Should the contractor refuse to go through with the work after having been awarded it by the City within the scheduled time, he shall then forfeit the Bid Surety to the City who shall use the surety to offset costs to the next lowest bidder or if the contractor fails to provide satisfactory performance and payment bonds as required. The bonding company must be licensed to do business in the State of Connecticut.

**4. WAGE RATES AND LABOR LAWS**

The wages paid on an hourly basis to any mechanic, laborer or workman employed upon the work herein contracted to be done and the amount of payment or contribution paid or payable on behalf of each such employee to any employee welfare fund, as defined in subsection (h) of section 1. of Public Act No. 93-392 shall be at a rate equal to the rate customary or prevailing for the same work in the same trade or occupation in the town of Norwich. Any contractor who is not obligated by agreement to make payment or contribution on behalf of such employees to any such employee welfare fund shall pay to each employee as part of his wages the amount of payment or contribution for his classification on each pay day.

Please be advised that effective October 1, 1993, Public Act 93-392 requires that all employers on a public works project shall submit weekly to the contracting agency a certified payroll and compliance statement. The certified payroll shall be considered a public record, and every person shall have the right to inspect and copy such records in accordance with the provisions of section 1-15, Connecticut General Statutes.

Upon award of the contract, the contractor shall certify under oath, to the labor commissioner the pay scale to be used by such contractor and any of his subcontractors for work to be performed under the contract.

The provisions of Public Act No. 93-392 shall not apply where the total cost of all work to be performed by all contractors and subcontractors in connection with new construction of any public works project is less than four hundred thousand dollars (\$400,000) or where the total cost of all work to be performed by all contractors and subcontractors in connection with any remodeling, refinishing, refurbishing, rehabilitation, alteration or repair of any public works project is less than one hundred thousand dollars (\$100,000).

All bidders are advised to inform themselves and to comply with the requirements of Federal, State and local laws governing the employment of labor.

5. **CONTRACTOR'S BONDS AND INSURANCE**

Each bidder must be able to enter into contract, covering the work, within 10 days from the acceptance of his proposal.

The successful bidder must, within ten (10) days from the date of acceptance of his proposal, furnish and file with the City of Norwich, a corporate surety bond or equivalent security, guaranteeing completion of the job in accordance with the proposal and a labor and material payment bond guaranteeing payment of all labor and materials furnished to himself or to his subcontractors for use in the prosecution of the work. This bond or equivalent shall be for 100% of the amount of the contract. The cost of the bonds is to be figured as part of the cost of the job. The Surety company must be one licensed to do business in the State of Connecticut and must be satisfactory to the City.

The successful bidder must, within ten (10) days from the date of acceptance of his proposal, file with the City of Norwich, Workmen's Compensation, Comprehensive General Liability, Comprehensive Auto Liability, Certificates of Insurance satisfactory to the City of Norwich, in compliance with the law, and in the following form and amount:

<b>COMPREHENSIVE GENERAL LIABILITY</b>	
Premises - Operations - Products/Completed Operations	
General Aggregate	\$2,000,000.00
Occurrence	\$2,000,000.00
<b>COMPREHENSIVE AUTOMOBILE LIABILITY</b>	
Combined Single Limit	\$1,000,000.00
<b>WORKMEN'S COMPENSATION</b>	Statutory
<b>EMPLOYERS LIABILITY;</b>	\$100,000

Fire and Special Extended Coverage in Builder's Risk policy in the amount of 100% of insurable completed value.

Any additional insurance coverage that may be required for permits issued by other authorities having jurisdiction over the work site shall be provided by the successful bidder.

If subcontractors are employed, same limits as named above shall apply and the certificate of insurance must be filed with the City.

No contract shall be binding upon the City of Norwich until such bond shall have been given and until Comprehensive General Liability, Comprehensive General Auto Liability and Workmen's Compensation policy certificates indicated above have been filed with the City and approved as to form and sufficiency by the City. The insurance policy certificate provided by the successful bidder and all subcontractors shall carry a statement by the insurance company that the City of Norwich will receive at least ten (10) days notice prior to cancellation of any portion of the policies or any modifications in the insurance coverage that may affect the City's interest. The cost of all insurance coverage shall be included in the price of the contract cost.

The insurance company must be licensed to do business in the State of Connecticut and must be satisfactory to the City of Norwich. THE CITY OF NORWICH MUST BE NAMED AS ADDITIONAL INSURED.

6. **NONRESIDENT CONTRACTOR BOND**

Connecticut General Statute Section 12-430(7) requires that when a nonresident contractor enters into a contract they must post a 5% cash or guarantee bond for the total contract amount with the Commissioner of Revenue Services. Bond forms are included at the end of the General Conditions.

7. **INDEMNITY OF CITY BY CONTRACTOR**

The Contractor shall indemnify and save harmless the City against any and all damages to property or injuries to or death of any person or persons, including property and employees or agents of the City, and shall defend, indemnify and save harmless the City from any and all claims, demands, suits, actions or proceedings of any kind of nature including workmen's compensation claims, of or by anyone whomsoever, in any way resulting from or arising out of the operations in connection herewith, including operations of subcontractors and acts or omissions of employees or agents of contractors or his subcontractors. Insurance coverage specified herein and in any special conditions constitutes the minimum requirements and said requirements shall in no way lessen or limit the liability of contractor under the terms of the contract. The contractor shall procure and maintain, at his own cost and expense, any additional kinds and amounts of insurance which in his own judgment, may be necessary for his proper protection in the prosecution of the work. The Contractor agrees to well and truly save and indemnify and keep harmless the City against all liability, judgments, costs and expenses which may in any wise come against the City or which may in any wise result from carelessness, omission or neglect of the Contractor or his agents, employees or workmen in any way arising or resulting from the operation in connection herewith, including all liability to the City resulting from the failure to maintain sufficient railing or fence as required by Section 13a-111, Conn. General Statutes, and against all liability from defects claimed to be in violation of Section 13a-149, Conn. General Statutes. Any additional cost of this save harmless insurance coverage shall be included in the price of the contract.

8. **PERMITS, LICENSES AND LAWS**

The contractor shall obtain all necessary permits or licenses from the proper authorities and shall give all notices required by law or ordinance, and shall pay all fees and charges incident to the due and lawful prosecution of the work and shall comply with all laws, ordinances and regulations relating thereto.

9. **RIGHT TO REJECT BIDS**

The City of Norwich reserves the right to reject any and all bids to waive any technicalities and to make such awards, including awards not to the lowest bidder, as it deems in its opinion to be the best interest of the City of Norwich, awards made by the City of Norwich shall be final and conclusive and without recourse or appeal by any remaining bidders.

10. **BIDDERS TO EXAMINE SPECIFICATIONS AND VISIT SITE OF WORK**

Bidders must carefully examine the specifications, and in addition must use whatever means may be necessary to completely satisfy themselves not only of the quantity of equipment and labor and the extent and requirements of the work, but also of the actual conditions under which the work specified is to be performed. It is therefore pre-requisite that all bidders shall visit the site of the work to determine actual conditions for themselves. No future plea of ignorance of existing conditions shall be considered as a basis for additional compensation.

If bidders fail to fully understand any clause or requirement of the specifications, inquiry must be made of the City's Representative for his interpretation of the specifications in advance of the submission of a bid. Failure on the part of the bidder to acquaint themselves thoroughly with the work to be performed and the conditions under which it will be performed will not be considered as a valid excuse for claims of any kind after the award of the contract. The signature of the bidder upon the bid shall be considered proof of his acceptance of full responsibility in this respect.

11. **REPRESENTATION OF CONTRACTOR**

The contractor represents and warrants that he is financially solvent and that he is experienced and competent to perform the type of work outlined on the specifications and drawings and that he has carefully examined the drawings and specifications along with addendum (or addenda), if any, and the site of the work, and that from his own investigations, he has satisfied himself as to the nature and location of the work, the character, quality and quantity of the surface and subsurface materials likely to be encountered, the character of equipment and other facilities needed for the performance of the work, the general and local conditions and all other materials which may in any way affect the work or its performance and that he is aware of the hazards involved in the work and the danger to life and property both evident and inherent and that he will conduct the work in a careful and safe manner without injury to persons or property. He further warrants that any injury to persons or property resulting from the work shall be the sole responsibility of the contractor.



12. **COMPETENT HELP TO BE EMPLOYED**

The contractor shall employ an experienced superintendent and foremen, craftsmen and other workmen competent in the work in which they are to be engaged. All work shall be accomplished by able, skilled and competent personnel. If any person employed on the work by the Contractor shall appear to be incompetent or unreliable in any way, or guilty of being noisy, profane, or otherwise disruptive to the surrounding working environment, he shall be discharged immediately upon the request of the City and shall not again be employed on the work.

13. **PROHIBITING EMPLOYEE DISCRIMINATION BY CONTRACTOR**

The contractor agrees and warrants that in the performance of this contract he will not discriminate or permit discrimination against any person applicant for employment or group of persons on the grounds of race, color, religion, national origin, sex, or physical disability, including but not limited to, blindness, unless it is shown by the contractor that such disability prevents performance of the work involved in any manner prohibited by the laws of the United States or of the State of Connecticut and further agrees to provide the commission on human rights and opportunities with such information requested by the commission concerning the employment practices and procedures of the contractor as related to the provisions of this section.

14. **SCOPE OF WORK**

The contractor, as promptly and as economically as practicable, shall perform all necessary engineering services, shall procure, order and furnish all of the required materials (unless furnished by the City), labor, equipment, tools, plant, etc. and perform all of the services necessary for the construction, installation and completion of, and shall construct, install and complete all work called for and described in the specifications, drawings and other descriptive data that may be referred to herein. The Department will provide bench marks and control stakes in order to complete the work. The contractor shall protect and maintain these points for the duration of the construction. It is the obligation of the contractor to utilize these bench marks and stakes to determine lines and grades, and to provide his own grade stakes.

15. **MATERIALS**

Unless otherwise specified the Contractor warrants that all materials shall be new and shall be of good quality. The Contractor shall, if required by the City, furnish samples or other satisfactory evidence as to the kind and quality of materials as directed by the City, and all materials there- after furnished by the Contractor shall be in strict accordance with such approved samples.

16. **SUB-CONTRACTS**

The Contractor agrees to obtain the agreement of every subcontractor to be bound to terms and conditions materially and substantially comparable to those contained herein unless otherwise authorized and approved by the City.

17. **ASSIGNMENT**

No assignment or transfer of the contract, or of any money or moneys due or to become due thereunder, or any part of such contract or of such money, will be permitted, until and unless the same shall be approved by the City, nor shall the contractor subcontract any substantial portion of this contract without City's written consent.

18. **SEPARATE CONTRACTS**

The City shall have the right to let other contracts in connection with this work or other work and the Contractor shall afford other Contractors reasonable opportunity for the execution of their work and shall properly connect and coordinate its work with theirs. The Contractor shall be liable for any damage that it, its agents or employees may cause to any other contractor and shall save City harmless therefrom. The City also reserves the right to perform work related to the contract with his own employees.

19. **PARTIAL INVALIDITY**

The City and Contractor agree that they will perform their obligations hereunder in accordance with all applicable laws, rules, regulations and ordinances now and hereafter in effect. If any term or provision of these conditions shall be found to be illegal or unenforceable then, notwithstanding, these conditions shall remain in full force and effect and such term or provision shall be deemed stricken.

20. **LIGHTS, BARRIERS, FENCES, WATCHMEN AND INDEMNITY**

The Contractor shall put up and maintain such barriers, fences, lighting and warning lights, danger warning signals and signs as will absolutely prevent accidents during the construction work and protect the work and insure the safety of personnel and public at all times and places; and the contractor shall defend, indemnify and save harmless the City and its agents in every respect from any injury or damage whatsoever caused by any act, omission or neglect of the contractor or his sub-contractor, or their servants or agents including any claims arising out of failure to erect and maintain sufficient railing or fence as required by Section 13a-111, Connecticut General Statutes. The fact that the City may retain the control of the premises, or that it or its agents may take action to erect or maintain railings or fences shall not relieve the contractor's obligation hereunder.

Contractor shall furnish, maintain and use, and cause all his sub-contractors to furnish, maintain and use all necessary safety devices and safe practices in prosecution of the work and to adopt, follow and maintain such additional safety measures as in the opinion of the City's Representative are conducive to safe operation by the contractor and the sub-contractor. The City's Representative shall have the right to order any and all work suspended where, in the City's Representative's opinion such work is not being carried on in a safe and proper manner, or where persons and property are not being properly protected or safeguarded and such work shall not be resumed until the City's Representative's requirements have been met and the City's Representative has directed that work shall resume. The work required by the preceding paragraph shall be totally at the contractor's expense.

In addition to above, when and as necessary, or when required by the City, the contractor shall post signs and employ watchmen or flagmen for directing of traffic at the site and for excluding at all times unauthorized persons from the work, for which the contractor will not be paid additional compensation.

21. **FIRE PRECAUTION**

The Contractor shall take adequate precaution against fire; keep flammable material at an absolute minimum; and insure that such material is properly handled and stored. The contractor shall not permit fires to be built or open salamanders to be used in any part of the work without the express approval of the City.

22. **"OR APPROVED EQUAL" CLAUSE**

Whenever a particular brand, make of material, device or equipment is shown as required on bid form by using the name of the proprietary product of a particular manufacturer or vendor, it is to be regarded merely as standard. Any brand, make of material, device or equipment which will perform adequately, may be considered equal and satisfactory providing the bidder offering "or equal" brand, make of material, device or equipment will be responsible for furnishing complete data to the City so that he may ascertain if the material is of equal substance and function in his (the City's) opinion. It shall not be purchased or installed without his written permission.

23. **TERMINATION FOR CONVENIENCE**

The City hereby reserves the right to terminate the performance of this contract for any reason the City deems appropriate, upon five (5) days written notice to the contractor. The City will pay all actual costs to date of termination, however the contractor shall not be entitled to any profit on unfinished or unearned work.

24. **TITLE TO WORK**

The title to all work completed or in the course of construction, and all materials on account of which any payment has been made by the City to the Contractor, shall be in the City.

25. **TIME OF COMPLETION**

The contractor shall commence work immediately upon receiving notification from the City's Representative to do so unless otherwise stated in the bid form and shall follow-up the work diligently without interruption until completed in accordance with the specifications, on or before the date set forth in the specifications.

26. **INSPECTION**

The City or persons designated by the City shall have access to and the right to inspect all work in the course of construction.

27. **SPIRITUOUS LIQUORS**

The contractor shall neither permit nor suffer the introduction or use of spirituous liquors upon the work embraced in this contract. Dope or drugs of any kind unless ordered by a physician are prohibited. Any employee found using spirituous liquors, dope or drugs of any kind unless ordered by a physician shall be immediately discharged.

28. **WORK CHANGES**

The City may make changes by altering, adding to or deleting from the work, without invalidating the contract, but all such changes must be mutually agreed upon in writing, after a breakdown of estimated costs and changes in the contract sum attributable thereto and a statement of any necessary changes in time of completion, between the City and the contractor before proceeding with the execution of the work. All such changes in the work shall be authorized on a change order. Charges or credits for work covered by the approved change shall be either (a) an agreed lump sum or (b) actual cost.

29. **CLAIMS FOR EXTRA WORK**

After the contract has been signed, no claims for extra work will be honored, unless authorized in writing by City.

30. **DEFAULTS**

If the contractor shall fail in this prosecution of the work under this contract, to perform any provisions of this contract, the City after a five (5) days written notice to the contractor to remedy said failure, and upon the refusal or neglect of the contractor to remedy such failure, the City, without prejudice to any other remedy the City may have, shall be entitled to remedy such deficiency and any cost thereby incurred by the City shall be paid for the account of the Contractor and deducted from the contract sum then or thereafter due the contractor. Any expense or cost arising out of the contractor's negligence, or that of its agents or employees for replacing defective work, and for the disposal of material wrongly supplied, may be paid by the City for the account of the Contractors and deducted from the contract sum then or thereafter due the contractor.

31. **TAXES**

Purchases made by the City of Norwich, Connecticut, are considered exempt from the payment of Federal excise taxes, Connecticut Sales Taxes, etc. and such taxes shall be identified separately or excluded from the bid prices.

32. **OCCUPATIONAL SAFETY AND HEALTH ACT OF 1970**

The contractor shall also insure that all his operations and those of his sub-contractor abide by the provisions of the William Steiger Occupational Safety and Health Act of 1970, Public Law 91-956 and all subsequent amendments. In the event of any inconsistencies between the above laws and regulations and the provisions of these conditions, the laws and regulations shall prevail. If the City or Representative assigned to the work find the contractor or his sub-contractor are not abiding with this act, the City shall immediately stop all work until the contractor or sub-contractor adhere to the provisions of the act at no additional cost to the City.

33. **COMPLIANCE WITH NON-DISCRIMINATION**

Through the policies and programs set forth in this plan, the City of Norwich undertakes to comply fully with all applicable Federal, State and Local laws relating to equal employment opportunity, affirmative action, and non-discrimination, and of the contractor's obligations thereunder. The City will not enter into any contract in the knowledge or belief that the contractor will discriminate on prohibited grounds in employment.

In addition, the City of Norwich is specifically obligated to comply with the following laws and regulations where applicable.

- Section 109, Housing & Community Development Act
- Titles VI and VII, Civil Rights Act of 1964
- Title VIII, Civil Rights Act of 1968
- Executive Order 11063
- Section 3, Housing & Urban Development Act of 1968
- Davis Bacon Act (40 U.S.C. 276A - 276A-7)

34. **WORK IN INCLEMENT WEATHER**

The City or the City's Representative will determine when conditions are unfavorable for work and may order the work or any portion of it suspended whenever, in his opinion the conditions are not such as will insure first class work. In general, work shall be prosecuted throughout the year and the Contractor will be expected to keep work going and employment of labor as continuous as possible. However, the Contractor shall, and shall cause his sub-contractors to protect carefully his and their work against damage of injury from the weather. If this is not done to the City's satisfaction and any damage to the work occurs, the work shall be removed and replaced at the expense of the contractor.

**35. PROTECTION OF TREES**

The Contractor shall take special care to preserve and protect from injury all trees located along the line of construction and no such trees shall be cut down, trimmed or otherwise cut without permission of the City.

**36. ARCHEOLOGICAL FINDS**

The Contractor for the life of this contract, is herewith required to immediately notify the Engineer in the event that any articles such as "charcoal", "bone", "shell", "cultural objects", "fire cracked stones", or "stone flaking material" or any other such related items of historical significance are discovered.

**37. BLASTING**

The approval of the City shall first be obtained before blasting is permitted. Before any explosive, such as dynamite or detonator caps, are stored or used, the contractor shall contact the Fire Department of the City of Norwich for instructions relative to the regulations for possession and use of explosives in the City of Norwich, Connecticut. The Contractor shall obtain all required permits and licenses for possession and use of explosives to be used on the sites of construction.

The Contractor shall also be responsible for the explosive materials at all times; for keeping of records regarding the explosives open at all times to inspection by the Police and Fire Departments of the City of Norwich, Connecticut; for the storage of explosive materials in a secure manner away from all tools, overnight or for any length of time at the site of construction; for the keeping of only such quantity of explosive material as may be needed for the work underway; for the immediate reporting to the Police and Fire Departments of the City of Norwich, Connecticut, of all unaccounted for explosive materials; for completely, adequately and carefully covering all blasts with suitable blasting mats in such a manner to prevent damage to landscape features, structures, facilities, privately owned and all other properties and surrounding objects and in a manner that will prevent injury to persons.

Unless specifically permitted, no blasting shall be done between the hours of sunset and sunrise on any day and no blasting will be allowed on Sundays or legal holidays.

Receptacles especially constructed for use in the storage of explosives shall be provided for the storage of explosives and they shall be proof against bullets, fire or other conditions which might cause explosions of the contents. When the need for explosives is ended, all such materials remaining on the job shall be promptly removed from the premises.

The Contractor shall be responsible for conducting any visual surveys and documentary photography in the immediate vicinity of the proposed blast site prior to any blasting. The cost of conducting such surveys and photography shall be included in the unit prices for rock removal.

When blasting is not approved by the City, alternate means of rock removal shall be used, such as mechanical splitting or hydraulically splitting. If specified in the contract, the Contractor must perform tests on well water and structures prior to any blasting.

**38. POWER AND WATER**

Should the Contractor require electric power and/or water, he shall make necessary arrangements with the Norwich Public Utilities Department for securing it and bear any expense involved, unless expressly provided for otherwise in the specifications.

**39. TOILET ACCOMMODATIONS**

The Contractor shall provide necessary sanitary toilet accommodations maintained in a sanitary condition for the workmen; chemical toilets will be permitted.

**40. CLEAN-UP**

The Contractor shall regularly and at the completion of the job, clean up all excess backfill materials and debris of every nature in order that the sites worked upon shall be left in a presentable condition as existed at the start of the job. It shall be the responsibility of the contractor to sweep and wash all surfaces and where mortar or grout has been deposited before these materials have an opportunity to bond. In case of dispute, the City may remove the rubbish and charge the cost of such removal to the Contractor.

41. **GENERAL GUARANTEE**

The Contractor shall guarantee his work for a period of one (1) year after the date of the City's Representative's final inspection and acceptance as evidenced by final payment. He shall during that period repair promptly, at his own cost and expense all breaks, failures or defects which develop in his work as a result of a faulty material or workmanship and indemnify and hold harmless the City from and against all loss or damage arising out of or in connection with any such defects.

42. **LIENS**

The final payment for the work will not be made until the City is satisfied that no liens have, or can be placed for material or labor on this work. If required by the City, the contractor shall deliver to the City a complete release of all liens arising out of this contract, or receipts in full covering all material and labor for which a lien could be filed against the City.

43. **PAYMENTS**

Payment for the work will be made when the work outlined in the specifications is completed or in accordance with the terms stated herein. Invoices shall be prepared in prescribed form by the contractor and shall be submitted to the City's Representative for checking and certification. *The City shall retain 5% of invoices until substantial completion of the project is reached. Retainage shall be reduced to 2% upon discretion of the City at that time.*

44. **PAYMENT TO SUB-CONTRACTOR**

The City assumes no obligation to pay or to see to the payment of any sum to the sub-contractor. The City can require a release of all liens for labor. (See Article 41)

45. **FINAL INSPECTION AND ACCEPTANCE**

Upon receipt of written notice from the contractor that his work is completed the City's Representative will make a final inspection and will notify the contractor of all instances in which the work fails to comply with the specifications as well as any defects which he may discover. The contractor shall thereupon immediately rebuild, alter and restore the work so that it will comply with the specifications and he shall remedy any defects at this own cost and expense and to the satisfaction of the City's Representative. Upon the completion of such alterations or repairs, the City's Representative will issue his certificate of final acceptance of work. The issuance of such certificate of final acceptance by the City's Representative shall not prevent the City from recovering damages at any subsequent time for work found to be actually defective during the one year guarantee period that commences after final payment has been made.

46. **FINAL PAYMENT**

The acceptance by the contractor of payment for the final invoice made after the City's Representative's certification of final acceptance as provided for in these General Conditions, shall release the City of Norwich and every agent of the City from all further claims or liabilities to the contractor of whatever nature except for the remaining sum or sums of money withheld under the provisions of the contract.

47. **CORRECTIONS**

Erasures or other changes in the bid must be explained or noted over the signature of the bidder.

48. **INTERPRETATION OF DRAWINGS AND SPECIFICATIONS**

The contractor shall keep at the site of the work at least one copy of the drawings and specifications, and shall at all times give the City and his representatives access thereto. Anything shown on the Drawings and not mentioned in the Specifications, or mentioned in the Specifications and not shown on the Drawings, shall have the same effect as if shown or mentioned on both.

49. **LOADING**

No part of the materials involved in this contract shall be loaded during construction with a load greater than that it can carry with safety. Should any accidents or damages occur through any violation of this requirement, the contractor will be held responsible under his contract and bond.

50. **POLLUTION OF WATERS**

Special care shall be taken to prevent contamination or muddying up or interfering in any way with the stream flows along the line of work. No Waste matter of any kind will be allowed to discharge into the stream flows or impounded waters of any ponds or other bodies of water.

**51. USE OF "HE", "HIS" OR "HIM"**

Whenever in these General Conditions the masculine words, "he", "his" or "him" are used pertaining to the contractor or buyer, it shall be for brevity and in no way is any sexual discrimination intended.

**52. REFERENCE**

Any reference to sections or articles shall be construed as pertaining to Connecticut State Highway Standard Specifications Form 816.

**53. SURPLUS MATERIAL**

The surplus material, if requested by the Engineer, shall be placed in designated areas, provided the haul does not exceed 1.5 miles. Should no area be designated, the Contractor shall dispose of the material beyond the limits of this project and in both instances this work will be done at no cost to the city.



## City of Norwich Connecticut

Department of Finance/Purchasing  
100 Broadway, Room 105  
Norwich, CT 06360-4431

Telephone Number:  
(860)823-3706

Fax Number:  
(860)823-3812

<http://www.norwichct.org>

### Standard Bid and Contract Terms and Conditions

All Invitations for Bids issued by the City of Norwich ("City") will bind Bidders to the terms and conditions listed below, unless specified otherwise in any individual Invitation for Bids.

The contractor agrees to comply with the statutes and regulations as they exist on the date of this contract and as they may be adopted or amended from time to time during the term of this contract and any amendments thereto.

#### Submission of Bids

1. Bids must be submitted on forms supplied by the City Purchasing Department. Telephone or facsimile Bids will not be accepted in response to an Invitation for Bids.
2. Bidders shall bear any and all costs associated with response to this invitation to Bid, including the costs for any presentation and/or demonstrations (if applicable).
3. The time and date Bids are to be opened is given in each Bid issued. Bids received after the specified time and date of Bid opening given in each Bid shall not be considered. **Bid envelopes must clearly indicate the Bid number** as well as the date and time of the opening of the Bid. The name and address of the Bidders shall appear in the upper left hand corner of the envelope.
4. If it becomes necessary to revise any part of this request or if additional data is necessary to enable interpretation of provisions of this document, revisions or addenda will be provided to all prospective firms who receive this document; such revisions or addenda will additionally be posted on the following websites:  
<http://www.norwichct.org>  
<http://das.ct.gov>
5. This document includes an acknowledgement page; this page must be faxed back to the Purchasing Department, to ensure proper notification of changes to the published documents. The City of Norwich does not assume responsibility for any vendor that does not receive revisions or addenda, where the vendor has not acknowledged receipt of any portion thereof.
6. Incomplete Bid forms may result in the rejection of The Bid. Amendments to Bids received by the City after the time specified for opening of Bids, shall not be considered. Bids shall be computer prepared, typewritten or handwritten in ink. All Bids shall be signed by a person duly authorized to sign Bids on behalf of the Bidders. Unsigned Bids shall be rejected. Errors, alterations or corrections on both the original and copy of the Bid schedule to be returned must be initialed by the person signing the Bid or their authorized designee. In the event an authorized designee initials the correction, there must be written authorization from the person signing the Bid to the person initialing the erasure, alterations, or correction. Failure to do so shall result in rejection of Bid for those items erased, altered or corrected and not initialed.
7. The City of Norwich reserves the right to accept or reject any and all Bid responses, in whole or in part, to waive technical defects, irregularities and omissions if, in its judgment, the best interests of the City will be served. Determination of the best interests of the City shall include consideration of pending civil litigation between the City and any firm submitting a Bid to the City or its subcontractor or supplier. The City also reserves the right to make multiple awards.
8. Conditional Bids are subject to rejection in whole or In part. A conditional Bid is defined as one which limits, modifies, expands or supplements any of the terms and conditions and/or specifications of the invitation for Bids.
9. Alternate Bids will not be considered, unless specifically authorized in the invitation to Bid. An alternate Bid is defined as one which is submitted in addition to the Bidders primary response to the invitation for Bids.
10. Prices should be extended in decimal, not fraction, to be net, and shall include transportation and delivery charges fully prepaid by the Contractor to the destination specified in the Bid, and subject only to cash discount. In the event of a



## City of Norwich Connecticut

Department of Finance/Purchasing  
100 Broadway, Room 105  
Norwich, CT 06360-4431

Telephone Number:  
(860)823-3706

Fax Number:  
(860)823-3812

<http://www.norwichct.org>

### Standard Bid and Contract Terms and Conditions

discrepancy between the unit price and the extension, the unit price shall govern.

11. Pursuant to Section 12-412 of the Connecticut General Statutes, municipalities are exempt from the payment of excise, transportation and sales taxes imposed by the Federal Government and/or the State. Such taxes must not be included in Bid prices.
12. By its submission the Bidder represents that the Bid is not made in connection with any other Bidders submitting a Bid for the same commodity or commodities and is in all respects fair and without collusion or fraud.
13. All Bids will be opened and read publicly and upon award are subject to public inspection, subject to the provisions of Section 1-210 of the Connecticut General Statutes (Freedom of Information). Copies of information resulting from any Bid opening are generally not available until a contract has been formally awarded.
14. Bid and or performance bonds may be required, if specifically required within the specifications. Bonds must meet the following requirements:

**Corporation** - must be signed by an official of the corporation above their official title and the corporate seal must be affixed over the signature; **Firm or Partnership** - must be signed by all the partners and indicate they are "doing business as"; **Individual** - must be signed by the owner and indicated as "Owner". The surety company executing the bond or countersigning must be licensed in Connecticut and the bond must be signed by an official of the surety company with the corporate seal affixed over their signature. Signatures of two witnesses for both the principal and the surety must appear on the bond. Power of attorney for the official signing the bond for the surety company must be submitted with the bond.

15. The City requires the Contractor to carry commercial general liability insurance to protect it from loss. The following minimum limits shall be met:  
**Bodily Injury and Property Damage:** \$1,000,000 each occurrence; \$2,000,000 aggregate  
**Products or Completed Operations:** \$1,000,000 each occurrence; \$2,000,000 aggregate and be written with a per project aggregate.  
**Professional Liability (Errors and Omissions):** \$2,000,000 each occurrence  
**Commercial Automobile Coverage including owned, non-owned, leased and hired vehicles (if used on City property):** \$1,000,000 combined single limit for each accident  
**Workers' Compensation:** Shall be in accordance with State of Connecticut requirements at the time of Bid.  
**Umbrella/Excess Liability:** \$2,000,000 each occurrence; \$2,000,000 aggregate and providing coverage over the Commercial General Liability, Commercial Automobile Liability and the Employer Liability section of the Workers Compensation coverage..

The City of Norwich, its officers (both elected and appointed), employees, and agents shall be named as additional insured on all policies, except Professional Liability and Workers Compensation, on a primary and non-contributory basis.

All policies, except Professional Liability, shall contain a waiver of subrogation in favor of the City of Norwich, executed by the insurance company.

Thirty (30) days' notice of cancellation is required and must be provided to the City of Norwich via certified mail.

#### Samples

16. Accepted Bid samples do not supersede the Specifications for quality unless sample is superior in quality. All deliveries shall have at least the same quality as the accepted Bid sample. Samples are furnished free of charge. Samples may be held for comparison with deliveries.





## City of Norwich Connecticut

Department of Finance/Purchasing  
100 Broadway, Room 105  
Norwich, CT 06360-4431

Telephone Number:  
(860)823-3706

Fax Number:  
(860)823-3812

<http://www.norwichct.org>

### Standard Bid and Contract Terms and Conditions

#### Award

17. Award will be based on quality of the articles or services to be supplied, their conformance with specifications, delivery terms, price, administrative costs, past performance, and financial responsibility. The Purchasing Department may correct inaccurate awards resulting from clerical or administrative errors.
18. The Purchasing Department may reject any Bidders in default of any prior contract or guilty of misrepresentation or any Bidders with a member of its firm in default or guilty of misrepresentation.

#### Delinquent Tax Set Off

19. In accordance with §7-46 of the City of Norwich Code of Ordinances, the award of any contract for the performance of any work, or the furnishing of any services and/or materials or equipment, any vendor or successful bidder shall agree that any taxes, landfill fees or special assessments due from the vendor or successful bidder to the City of Norwich, unless previously paid, may be set off against any monies that may be due from the City of Norwich to the vendor or successful bidder for the performance of work or the furnishing of services and/or materials or equipment under said contract.
20. Any person, vendor or successful bidder performing any work or furnishing any services or material or equipment to the City or any department, board or agency thereof, shall, as a condition of doing such or furnishing services or material or equipment, agree that any delinquent taxes, landfill fees or special assessments due from him, her or it to the City, unless previously paid, may be set off against any monies that may be due from the City to such person, vendor or successful bidder for the performance of such work or the furnishing of services or materials or equipment.

#### Contract

21. The existence of the contract shall be determined in accordance with the requirements set forth above. However, the award of the contract is not an order to ship.
22. The Contractor shall not assign or otherwise dispose of their contract or their right, title or interest, or their power to execute such contract to any other person, firm or corporation without the prior written consent of the Purchasing Department.
23. Bidders have ten days after notice of award to refuse acceptance of the award; after ten days the award will be binding on the Contractor. If the Contractor refuses to accept the award within the ten day period, the award will be made to the next lowest responsible qualified Bidders.
24. Failure of a Contractor to deliver commodities or perform services as specified will constitute authority to purchase said commodities or services on the open market. Contractor agrees to promptly reimburse the City for excess cost of these purchases. The purchases will be deducted from the contracted quantities.
25. The Bidders hereinafter referred to as persons requesting the use of city facilities of the City of Norwich, or in contracting with the City of Norwich for goods, services, materials, labor and the like with the City of Norwich and its respective officers, agents, servants and employees agrees to indemnify, defend and save harmless from and against any and all claims, damages, losses, litigation expenses, counsel fees and compensation arising out of any injuries (including death) sustained by, or alleged to have been sustained by, the servants, employees or agents of the City of Norwich and its respective officers, agents, servants and employees, or of the Bidders or of any participant or spectator, and from injuries including death) sustained by, or alleged to have been sustained by, the public or any persons on or near the site or on any other person or damage to property, real or personal, including property of the City of Norwich and their respective officers, agents, servants and employees, caused in whole or in part by the acts or omission of the Bidders or any participant or spectator or anyone directly or indirectly employed or working for the Bidders while engaged in the activity in the City of Norwich.
26. Notwithstanding any provision or language in this contract to the contrary, the purchasing agent may terminate this



## City of Norwich Connecticut

Department of Finance/Purchasing  
100 Broadway, Room 105  
Norwich, CT 06360-4431

Telephone Number:  
(860)823-3706

Fax Number:  
(860)823-3812

<http://www.norwichct.org>

### Standard Bid and Contract Terms and Conditions

contract whenever he/she determines in his/her sole discretion that such termination is in the best interests of the City. Any such termination shall be effected by delivery to the Contractor of a written notice of termination. The notice of termination shall be sent by registered mail to the Contractor address furnished to the City for purposes of correspondence or by hand delivery. Upon receipt of such notice, the Contractor shall both immediately discontinue all services affected (unless the notice directs otherwise) and deliver to the City all data, drawings, specifications, reports, estimates, summaries, and such other information and materials as may have been accumulated by the Contractor in performing his duties under this contract, whether completed or in progress. All such documents, information, and materials shall become the property of the City. In the event of such termination, the Contractor shall be entitled to reasonable compensation as determined by the Office of Corporation Counsel for the City of Norwich, however, no compensation for lost profits shall be allowed.

27. Notwithstanding any provision or language in this contract to the contrary, the purchasing agent may terminate this contract for cause in the event of any default by the Contractor, or if the Contractor fails to comply with any contract terms and conditions, or fails to provide the City, upon request, with adequate assurances of future performance. In the event of termination for cause, the City shall not be liable to the Contractor for any amount of supplies or services not accepted, and the Contractor shall be liable to the City for any and all rights and remedies provided by law. If it is determined that the City improperly terminated this contract for default, such termination shall be deemed a termination for convenience.
28. The individual signing this submittal hereby declares that no person or persons other than members of his/her own organization are interested in this Project or in the contract proposed to be taken; that it is made without any connection with any other person or persons making a Bid for the same work and is in all respects fair and without collusion or fraud; that no person acting for or employed by the City of Norwich is directly or indirectly interested therein, or in the supplies or works to which it relates or will receive any part of the profit or any commission therefrom in any manner which is unethical or contrary to the best interests of the City of Norwich.

#### Delivery

29. All products and equipment delivered must be new, and shall include any and all manufacturer warranties, unless otherwise stated in the Bid specifications.
30. Delivery will be onto the specified City loading docks by the Contractor unless otherwise stated in the Bid specifications.
31. Payment terms are net 30 days after receipt of goods or properly executed invoice, whichever is later, unless otherwise specified. A contractor may quote payment discount terms which may be considered in making the award.

#### Saving Clause

32. The Contractor shall not be liable for losses or delays in the fulfillment of the terms of the contract due to wars, acts of public enemies, strikes, fires, floods, acts of God or any other acts not within the control of or reasonably prevented by the Contractor. The Contractor will give written notice of the cause and probable duration of any such delay.

#### Advertising

33. Contractors may not reference sales to the City for advertising and promotional purposes without the prior specific approval of the Purchasing Department.

#### Rights

34. Any and all data collected by the contractor relative to either the performance of services or delivery of materials shall remain the sole property of the City of Norwich. Such data includes historic usage of materials and services as collected by the contractor, as it relates to Norwich purchasing activity. The City has sole and exclusive right and title to all printed material produced for the City, whether acceptable or unacceptable, and the contractor shall not copyright any printed matter produced under the contract.



## City of Norwich Connecticut

Department of Finance/Purchasing  
100 Broadway, Room 105  
Norwich, CT 06360-4431

Telephone Number:  
(860)823-3706

Fax Number:  
(860)823-3812

<http://www.norwichct.org>

### Standard Bid and Contract Terms and Conditions

35. The Contractor assigns to the City all rights title and interests in and to all causes of action it may have under Section 4 of the Clayton Act, 15 USC 15, or under Chapter 624 of the general statutes. This assignment occurs when the Contractor is awarded the contract.
35. Contractor agrees that it is in compliance with all applicable federal, state and local laws and regulations, including but not limited to Connecticut General Statutes Sections 4a-60 and 4a-60a, 4a-60g, and 46a-68b through 46a-68f, inclusive, as amended by the June 2015 Special Session Public Act No. 15-5, as well as the provisions of Title VI of the Civil Rights Act of 1964 and all amendments thereto. The Contractor also agrees that it will hold the City harmless and indemnify the City from any action which may arise out of any act by the contractor concerning lack of compliance with these laws and regulations. All purchases will be in compliance with Section 22a-194 to Section 22a-194g of the Connecticut General Statutes related to product packaging.
36. This contract is subject to provisions of Executive Order No. Three of Governor Thomas J. Meskill promulgated June 16, 1971, the provisions of Executive Order No. Seventeen of Governor Thomas J. Meskill promulgated February 15, 1973 and section 16 of Public Act 91-58 nondiscrimination regarding sexual orientation, and the provisions of Executive Order No. Sixteen of Governor John G. Rowland promulgated August 4, 1999 regarding Violence in the Workplace Prevention Policy.

## SUPPLEMENTARY CDBG CONDITIONS

### Federal Requirements for Community Development Block Grant Funded Projects

Applicants are notified that this project is funded through the Department of Housing and Urban Development under the Housing and Community Development Act of 1974 as amended in 1977. Applicants are reminded that not less than the minimum wages and salaries as set forth in the Contract Documents must be paid on this project and that the Contractor must ensure that employees and applicants for employment are not discriminated against because of their race, color, religion, sex, national origin, age or handicapped status.

### Nondiscrimination

The Contractor agrees and warrants that in the performance of this contract he will not discriminate or permit discrimination against any person or group of persons on the grounds of race, color, religious creed, age, marital status, national origin, sex, mental retardation or physical disability, including, but not limited to, blindness, unless it is shown by such contractor that such disability prevents performance of the work involved in any manner prohibited by the laws of the United States or of the State of Connecticut, and further agrees to provide the Commission on Human Rights and Opportunities with such information requested by the Commission concerning the employment practices and procedures of the Contractor as they relate to the provisions of this section.

### Equal Opportunity

During the performance of this Contract, the Contractor agrees as follows:

- (1) The Contractor will not discriminate against any employee or applicant for employment because of race, color, sex, religion, national origin, or age. The Contractor will take affirmative action to insure that applicants are employed and that employees are treated during employment without regard to their race, color, sex, religion, national origin, or age. Such action will include, but not be limited to the following: employment, upgrading, demotion, or transfer; recruitment or recruitment advertising; layoff or termination; rates of pay or other forms of compensation; and selection for training, including apprenticeship. The Contractor agrees to post in conspicuous places, available to employees and applicants for employment, notices to be provided by an appropriate agency of the Federal Government setting forth the requirements of these nondiscrimination provisions.
- (2) The Contractor will state in all solicitations and advertisement for employees placed by or on behalf of the contractor that all qualified applicants will receive consideration for employment without regard to race, color, sex, religion, national origin, or age.
- (3) The Contractor will send a notice provided by the Owner to each labor union or representative or workers with which he has a collective bargaining agreement or other contract or understanding advising the labor union or workers' representative of the Contractor's commitments under Section 202 of Executive Order No. 11246 of September 24, 1965, as amended, and will post copies of the notice in conspicuous places available to employees and applicants for employment.

(4) The Contractor will comply with all provisions of Executive Order No. 11246, and of the rules, regulations, and relevant orders by the Secretary of Labor.

(5) The Contractor will furnish all information and reports required by Executive Order No. 11246, and by the rules, regulations, and orders of the Secretary of Labor or pursuant thereto, and will permit access to his books, records and accounts by an appropriate agency of the Federal Government and by the Secretary of Labor for purposes of investigation to ascertain compliance with such rules, regulations and orders.

(6) In the event of the Contractor's noncompliance with equal opportunity conditions or with any such rules, regulations or orders, the Contract may be cancelled, terminated, or suspended in whole or in part, and the Contractor may be declared ineligible for further government contracts or federally assisted contracts in accordance with procedures authorized in Executive Order No. 11246, and such other sanctions may be imposed and remedies invoked as provided in the Executive Order, or by rule, regulation, or order of the Secretary of Labor, or as otherwise provided by law.

(7) The Contractor will include all Paragraphs (1)-(7) in every subcontract or purchase order the Contractor enters into unless exempted by rules, regulations, or orders of the Secretary of Labor issued pursuant of Section 202 or Executive Order No. 11246, so such provisions will be binding upon each subcontractor or vendor. The Contractor will take such action with respect to any subcontractor or vendor as the appropriate agency of the Federal Government may direct as a means of enforcing such provisions, including sanctions for noncompliance, provided, however, that in the event the Contractor becomes involved in, or is threatened by the appropriate agency of the Federal Government, the Contractor may request the United States to enter into such litigation to protect the interest of the United States.

#### Compliance with Federal Environmental Laws

In compliance with requirements of the Clean Air Act, as amended, 42 USC 1857 et seq., the Federal Water Pollution Control Act, as amended, 33 USC 1251 et seq. and the regulations of the Environmental Protection Agency with respect thereto, at 40 CFR Part 15, as amended:

(1) The contractor and any subcontractor stipulate that any facility to be utilized in the performance of any non-exempt contract or subcontract is not listed on the List of Violating Facilities issued by the Environmental Protection Agency (EPA).

(2) The contractor agrees to comply with all the requirements of section 114 of the Clean Air Act, as amended (42 USC 1857c-8) and section 308 of the Federal Water Pollution Control Act as amended (33USC-1318) relating to inspection monitoring, entry, reports and information, as well as all other requirements specified in said section 114 and section 308, and all regulations and guidelines issued thereunder.

(3) The contractor will give the City prompt notice of any notification received from the Director, Office of Federal Activities, EPA, indicating that a facility utilized or to be utilized for the contract is under consideration to be listed on the EPA List of Violating Facilities.

(4) The contractor will include or cause to be included the criteria and requirements in paragraph (1) through (4) of this section in every nonexempt subcontract and the contractor will take such action as the Governor may direct as a means of enforcing such provisions.

(5) Funded program recipients must comply with all state and Federal waste disposal laws, when conducting demolition. When properties are approved for demolition, program recipients must ensure that the demolition waste is properly disposed of at a permitted/licensed sanitary or demolition landfill.

#### Access to Contractor's Books, Documents, Papers and Records

The City of Norwich, the Department of Housing and Urban Development, the Comptroller General of the United States, or any of their duly authorized representatives, shall have access to any books, documents, papers and records of the contractor which are directly pertinent to the C.D. Block Grant Program for the purpose of making audit, examination, excerpts and transcriptions.

#### Wages

The wages paid to any mechanic, laborer or worker employed upon the work herein contracted to be done shall be at a rate equal to the rate of wages prevailing for the same work in the same trade or occupation in the Norwich area as determined by the Wage Requirements Office of the Department of Housing and Urban Development and shall comply with the Davis-Bacon Act. If a conflict between minimum Federal and State wage scales should occur, the higher of the two shall apply to this project.

In compliance with the Davis-Bacon Act, "For contracts exceeding \$2,000.00 each contractor or subcontractor shall furnish the recipient government within seven (7) days after the regular payment date of weekly payroll period, a Statement with respect to wages paid to each of the contractor's employees." The statement may be contained on Form WH-348 - "Statement of Compliance", or an identical form on the back of WH-347 "Payroll". Form WH-347 "Payroll" is to be submitted to the Office of Community Development, 23 Union Street, Norwich, Connecticut 06360 within seven (7) days following the end of the weekly payroll period.

#### Safety and Health Regulations

This project is subject to all of the safety and health regulations as promulgated by the United States Department of Labor. Contractors are urged to become familiar with the requirements of these regulations.

#### Prohibition and Elimination of Lead Based Paint Hazard

Notwithstanding any other provision, the Contractor agrees to comply with the regulations issued by the Secretary of Housing and Urban Development set forth in 24 CFR Part 35 and all applicable rules and orders issued there under which prohibit the use of lead-based paint in residential structures undergoing Federally assisted construction or rehabilitation and require the elimination of lead-based paint hazards.

### Conflict of Interest

No member, officer, or employee of the City of Norwich, or its designees or agents, no member of the governing body of the locality in which the program is situated, and no other public official of such locality or localities who exercise any function or responsibilities with respect to the program during his tenure or for one year thereafter, shall have any interest, direct or indirect, in this contract or the proceeds thereof.

### Federal Contract Provisions

- (1) Administrative, contractual, or legal remedies in instances where contractors violate or breach contract terms, and provide for such sanctions and penalties as may be appropriate. (Contracts more than the simplified acquisition threshold)
- (2) Termination for cause and for convenience by the grantee or subgrantee including the manner by which it will be effected and the basis for settlement. (All contracts in excess of \$10,000)
- (3) Compliance with Executive Order 11246 of September 24, 1965, entitled "Equal Employment Opportunity," as amended by Executive Order 11375 of October 13, 1967, and as supplemented in Department of Labor regulations (41 CFR chapter 60). (All construction contracts awarded in excess of \$10,000 by grantees and their contractors or subgrantees)
- (4) Compliance with the Copeland "Anti-Kickback" Act (18 U.S.C. 874) as supplemented in Department of Labor regulations (29 CFR part 3). (All contracts and subgrants for construction or repair)
- (5) Compliance with the Davis-Bacon Act (40 U.S.C. 276a to 276a-7) as supplemented by Department of Labor regulations (29 CFR part 5). (Construction contracts in excess of \$2000 awarded by grantees and subgrantees when required by Federal grant program legislation)
- (6) Compliance with Sections 103 and 107 of the Contract Work Hours and Safety Standards Act (40 U.S.C. 327A 330) as supplemented by Department of Labor regulations (29 CFR part 5). (Construction contracts awarded by grantees and subgrantees in excess of \$2000, and in excess of \$2500 for other contracts which involve the employment of mechanics or laborers)
- (7) Notice of awarding agency requirements and regulations pertaining to reporting.
- (8) Notice of awarding agency requirements and regulations pertaining to patent rights with respect to any discovery or invention which arises or is developed in the course of or under such contract.
- (9) Awarding agency requirements and regulations pertaining to copyrights and rights in data.
- (10) Access by the grantee, the subgrantee, the Federal grantor agency, the Comptroller General of the United States, or any of their duly authorized representatives to any books, documents, papers, and records of the contractor which are directly pertinent to that specific contract for the purpose of making audit, examination, excerpts, and transcriptions.
- (11) Retention of all required records for three years after grantees or subgrantees make final payments and all other pending matters are closed.
- (12) Compliance with all applicable standards, orders, or requirements issued under section 306 of the Clean Air Act (42 U.S.C. 1857 (h)), section 508 of the Clean Water Act (33 U.S.C. 1368),



Executive Order 11738, and Environmental Protection Agency regulations (40 CFR part 15). (Contracts, subcontracts, and subgrants of amounts in excess of \$100,000).

- (13) Mandatory standards and policies relating to energy efficiency which are contained in the state energy conservation plan issued in compliance with the Energy Policy and Conservation Act (Pub. L. 94A 163, 89 Stat. 871).
- (14) A contract award (see 2 CFR 180.220) must not be made to parties listed on the government-wide Excluded Parties List System in the System for Award Management (SAM), in accordance with the OMB guidelines at 2 CFR 180 that implement Executive Orders 12549 (3 CFR Part 1986 Comp., p. 189) and 12689 (3 CFR Part 1989 Comp., p. 235), "Debarment and Suspension." The Excluded Parties List in SAM contains the names of parties debarred, suspended, or otherwise excluded by agencies, as well as parties declared ineligible under statutory or regulatory authority other than Executive Order 12549.
- (15) Byrd Anti-Lobbying Amendment (31 U.S.C. 1352) – Contractors that apply or bid for an award of \$100,000 or more must file the required certification. Each tier certifies to the tier above that it will not and has not used Federal appropriated funds to pay any person or organization for influencing or attempting to influence an officer or employee of any agency, member of Congress, officer or employee of Congress, or an employee of a member of Congress in connection with obtaining any Federal contract, grant or any other award covered by 31 U.S.C. 1352. Each tier must also disclose any lobbying with non-Federal funds that takes place in connection with obtaining any Federal award. Such disclosures are forwarded from tier to tier up to the non-Federal award.

## **Executive Order 11246 — Equal Employment Opportunity**

SOURCE: The provisions of Executive Order 11246 of Sept. 24, 1965, appear at 30 FR 12319, 12935, 3 CFR, 1964-1965 Comp., p.339, unless otherwise noted.

Under and by virtue of the authority vested in me as President of the United States by the Constitution and statutes of the United States, it is ordered as follows:

### **Part I — Nondiscrimination in Government Employment**

[Part I superseded by EO 11478 of Aug. 8, 1969, 34 FR 12985, 3 CFR, 1966-1970 Comp., p. 803]

### **Part II - Nondiscrimination in Employment by Government Contractors and Subcontractors**

#### **Subpart A - Duties of the Secretary of Labor**

**SEC. 201.** The Secretary of Labor shall be responsible for the administration and enforcement of Parts II and III of this Order. The Secretary shall adopt such rules and regulations and issue such orders as are deemed necessary and appropriate to achieve the purposes of Parts II and III of this Order.

[Sec. 201 amended by EO 12086 of Oct. 5, 1978, 43 FR 46501, 3 CFR, 1978 Comp., p. 230]

#### **Subpart B - Contractors' Agreements**

**SEC. 202.** Except in contracts exempted in accordance with Section 204 of this Order, all Government contracting agencies shall include in every Government contract hereafter entered into the following provisions:

During the performance of this contract, the contractor agrees as follows:

1. The contractor will not discriminate against any employee or applicant for employment because of race, color, religion, sex, sexual orientation, gender identity, or national origin. The contractor will take affirmative action to ensure that applicants are employed, and that employees are treated during employment, without regard to their race, color, religion, sex, sexual orientation, gender identity, or national origin. Such action shall include, but not be limited to the following: employment, upgrading, demotion, or transfer; recruitment or recruitment advertising; layoff or termination; rates of pay or other forms of compensation; and selection for training, including apprenticeship. The contractor agrees to post in conspicuous places, available to employees and applicants for employment, notices to be provided by the contracting officer setting forth the provisions of this nondiscrimination clause.
2. The contractor will, in all solicitations or advancements for employees placed by or on behalf of the contractor, state that all qualified applicants will receive consideration for employment without regard to race, color, religion, sex, sexual orientation, gender identity, or national origin.
3. The contractor will not discharge or in any other manner discriminate against any employee or applicant for employment because such employee or applicant has inquired about, discussed, or disclosed the compensation of the employee or applicant or another employee or applicant. This provision shall not apply to instances in which an employee who has access to the compensation information of other employees or applicants as a part of such employee's essential job functions discloses the compensation of such other employees or applicants to individuals who do not otherwise have access to such information, unless such disclosure is in response to a formal complaint or charge, in furtherance of an investigation, proceeding, hearing, or action, including an investigation conducted by the employer, or is consistent with the contractor's legal duty to furnish information.
4. The contractor will send to each labor union or representative of workers with which he has a collective bargaining agreement or other contract or understanding, a notice, to be provided by the agency contracting

officer, advising the labor union or workers' representative of the contractor's commitments under Section 202 of Executive Order No. 11246 of September 24, 1965, and shall post copies of the notice in conspicuous places available to employees and applicants for employment.

5. The contractor will comply with all provisions of Executive Order No. 11246 of Sept. 24, 1965, and of the rules, regulations, and relevant orders of the Secretary of Labor.
6. The contractor will furnish all information and reports required by Executive Order No. 11246 of September 24, 1965, and by the rules, regulations, and orders of the Secretary of Labor, or pursuant thereto, and will permit access to his books, records, and accounts by the contracting agency and the Secretary of Labor for purposes of investigation to ascertain compliance with such rules, regulations, and orders.
7. In the event of the contractor's noncompliance with the nondiscrimination clauses of this contract or with any of such rules, regulations, or orders, this contract may be cancelled, terminated, or suspended in whole or in part and the contractor may be declared ineligible for further Government contracts in accordance with procedures authorized in Executive Order No. 11246 of Sept. 24, 1965, and such other sanctions may be imposed and remedies invoked as provided in Executive Order No. 11246 of September 24, 1965, or by rule, regulation, or order of the Secretary of Labor, or as otherwise provided by law.
8. The contractor will include the provisions of paragraphs (1) through (8) in every subcontract or purchase order unless exempted by rules, regulations, or orders of the Secretary of Labor issued pursuant to Section 204 of Executive Order No. 11246 of September 24, 1965, so that such provisions will be binding upon each subcontractor or vendor. The contractor will take such action with respect to any subcontract or purchase order as may be directed by the Secretary of Labor as a means of enforcing such provisions including sanctions for noncompliance: Provided, however, that in the event the contractor becomes involved in, or is threatened with, litigation with a subcontractor or vendor as a result of such direction, the contractor may request the United States to enter into such litigation to protect the interests of the United States." [Sec. 202 amended by EO 11375 of Oct. 13, 1967, 32 FR 14303, 3 CFR, 1966-1970 Comp., p. 684, EO 12086 of Oct. 5, 1978, 43 FR 46501, 3 CFR, 1978 Comp., p. 230, EO 13665 of April 8, 2014, 79 FR 20749, EO 13672 of July 21, 2014, 79 FR 42971]

### **SEC. 203.**

- a. Each contractor having a contract containing the provisions prescribed in Section 202 shall file, and shall cause each of his subcontractors to file, Compliance Reports with the contracting agency or the Secretary of Labor as may be directed. Compliance Reports shall be filed within such times and shall contain such information as to the practices, policies, programs, and employment policies, programs, and employment statistics of the contractor and each subcontractor, and shall be in such form, as the Secretary of Labor may prescribe.
- b. Bidders or prospective contractors or subcontractors may be required to state whether they have participated in any previous contract subject to the provisions of this Order, or any preceding similar Executive order, and in that event to submit, on behalf of themselves and their proposed subcontractors, Compliance Reports prior to or as an initial part of their bid or negotiation of a contract.
- c. Whenever the contractor or subcontractor has a collective bargaining agreement or other contract or understanding with a labor union or an agency referring workers or providing or supervising apprenticeship or training for such workers, the Compliance Report shall include such information as to such labor union's or agency's practices and policies affecting compliance as the Secretary of Labor may prescribe: Provided, That to the extent such information is within the exclusive possession of a labor union or an agency referring workers or providing or supervising apprenticeship or training and such labor union or agency shall refuse to furnish such information to the contractor, the contractor shall so certify to the Secretary of Labor as part of its Compliance Report and shall set forth what efforts he has made to obtain such information.
- d. The Secretary of Labor may direct that any bidder or prospective contractor or subcontractor shall submit, as part of his Compliance Report, a statement in writing, signed by an authorized officer or agent on behalf of any labor union or any agency referring workers or providing or supervising apprenticeship or other training, with which the bidder or prospective contractor deals, with supporting information, to the effect that the signer's practices and policies do not discriminate on the grounds of race, color, religion, sex, sexual orientation, gender identity, or national origin, and that the signer either will affirmatively cooperate in the implementation of the policy and provisions of this Order or that it consents and agrees that recruitment, employment, and the terms and conditions of employment under the proposed contract shall be in accordance with the purposes and

provisions of the order. In the event that the union, or the agency shall refuse to execute such a statement, the Compliance Report shall so certify and set forth what efforts have been made to secure such a statement and such additional factual material as the Secretary of Labor may require.

[Sec. 203 amended by EO 11375 of Oct. 13, 1967, 32 FR 14303, 3 CFR, 1966-1970 Comp., p. 684; EO 12086 of Oct. 5, 1978, 43 FR 46501, 3 CFR, 1978 Comp., p. 230, EO 13672 of July 21, 2104, 79 FR 42971]

#### **SEC. 204**

- a. The Secretary of Labor may, when the Secretary deems that special circumstances in the national interest so require, exempt a contracting agency from the requirement of including any or all of the provisions of Section 202 of this **Order** in any specific contract, subcontract, or purchase **order**.
- b. The Secretary of Labor may, by rule or regulation, exempt certain classes of contracts, subcontracts, or purchase orders (1) whenever work is to be or has been performed outside the United States and no recruitment of workers within the limits of the United States is involved; (2) for standard commercial supplies or raw materials; (3) involving less than specified amounts of money or specified numbers of workers; or (4) to the extent that they involve subcontracts below a specified tier.
- c. Section 202 of this **Order** shall not apply to a Government contractor or subcontractor that is a religious corporation, association, educational institution, or society, with respect to the employment of individuals of a particular religion to perform work connected with the carrying on by such corporation, association, educational institution, or society of its activities. Such contractors and subcontractors are not exempted or excused from complying with the other requirements contained in this **Order**.
- d. The Secretary of Labor may also provide, by rule, regulation, or order, for the exemption of facilities of a contractor that are in all respects separate and distinct from activities of the contractor related to the performance of the contract: provided, that such an exemption will not interfere with or impede the effectuation of the purposes of this **Order**: and provided further, that in the absence of such an exemption all facilities shall be covered by the provisions of this **Order**."

[Sec. 204 amended by EO 13279 of Dec. 16, 2002, 67 FR 77141, 3 CFR, 2002 Comp., p. 77141 - 77144]

#### **Subpart C - Powers and Duties of the Secretary of Labor and the Contracting Agencies**

**SEC. 205.** The Secretary of Labor shall be responsible for securing compliance by all Government contractors and subcontractors with this Order and any implementing rules or regulations. All contracting agencies shall comply with the terms of this Order and any implementing rules, regulations, or orders of the Secretary of Labor. Contracting agencies shall cooperate with the Secretary of Labor and shall furnish such information and assistance as the Secretary may require.

[Sec. 205 amended by EO 12086 of Oct. 5, 1978, 43 FR 46501, 3 CFR, 1978 Comp., p. 230]

#### **SEC. 206.**

- a. The Secretary of Labor may investigate the employment practices of any Government contractor or subcontractor to determine whether or not the contractual provisions specified in Section 202 of this Order have been violated. Such investigation shall be conducted in accordance with the procedures established by the Secretary of Labor.
- b. The Secretary of Labor may receive and investigate complaints by employees or prospective employees of a Government contractor or subcontractor which allege discrimination contrary to the contractual provisions specified in Section 202 of this Order.

[Sec. 206 amended by EO 12086 of Oct. 5, 1978, 43 FR 46501, 3 CFR, 1978 Comp., p. 230]

**SEC. 207.** The Secretary of Labor shall use his/her best efforts, directly and through interested Federal, State, and local agencies, contractors, and all other available instrumentalities to cause any labor union engaged in work under Government contracts or any agency referring workers or providing or supervising apprenticeship or training for or in the course of such work to cooperate in the implementation of the purposes of this Order. The Secretary of Labor shall, in appropriate cases, notify the Equal Employment Opportunity Commission, the Department of Justice, or other appropriate Federal agencies whenever it has reason to believe that the practices of any such labor organization or agency violate Title VI or Title VII of the Civil Rights Act of 1964 or other provision of Federal law.

[Sec. 207 amended by EO 12086 of Oct. 5, 1978, 43 FR 46501, 3 CFR, 1978 Comp., p. 230]

**SEC. 208.**

- a. The Secretary of Labor, or any agency, officer, or employee in the executive branch of the Government designated by rule, regulation, or order of the Secretary, may hold such hearings, public or private, as the Secretary may deem advisable for compliance, enforcement, or educational purposes.
- b. The Secretary of Labor may hold, or cause to be held, hearings in accordance with Subsection of this Section prior to imposing, ordering, or recommending the imposition of penalties and sanctions under this Order. No order for debarment of any contractor from further Government contracts under Section 209(6) shall be made without affording the contractor an opportunity for a hearing.

**Subpart D - Sanctions and Penalties**

**SEC. 209.** In accordance with such rules, regulations, or orders as the Secretary of Labor may issue or adopt, the Secretary may:

1. Publish, or cause to be published, the names of contractors or unions which it has concluded have complied or have failed to comply with the provisions of this Order or of the rules, regulations, and orders of the Secretary of Labor.
2. Recommend to the Department of Justice that, in cases in which there is substantial or material violation or the threat of substantial or material violation of the contractual provisions set forth in Section 202 of this Order, appropriate proceedings be brought to enforce those provisions, including the enjoining, within the limitations of applicable law, of organizations, individuals, or groups who prevent directly or indirectly, or seek to prevent directly or indirectly, compliance with the provisions of this Order.
3. Recommend to the Equal Employment Opportunity Commission or the Department of Justice that appropriate proceedings be instituted under Title VII of the Civil Rights Act of 1964.
4. Recommend to the Department of Justice that criminal proceedings be brought for the furnishing of false information to any contracting agency or to the Secretary of Labor as the case may be.
5. After consulting with the contracting agency, direct the contracting agency to cancel, terminate, suspend, or cause to be cancelled, terminated, or suspended, any contract, or any portion or portions thereof, for failure of the contractor or subcontractor to comply with equal employment opportunity provisions of the contract. Contracts may be cancelled, terminated, or suspended absolutely or continuance of contracts may be conditioned upon a program for future compliance approved by the Secretary of Labor.
6. Provide that any contracting agency shall refrain from entering into further contracts, or extensions or other modifications of existing contracts, with any noncomplying contractor, until such contractor has satisfied the Secretary of Labor that such contractor has established and will carry out personnel and employment policies in compliance with the provisions of this Order.

(b) Pursuant to rules and regulations prescribed by the Secretary of Labor, the Secretary shall make reasonable efforts, within a reasonable time limitation, to secure compliance with the contract provisions of this Order by methods of conference, conciliation, mediation, and persuasion before proceedings shall be instituted under subsection (a)(2) of this Section, or before a contract shall be cancelled or terminated in whole or in part under subsection (a)(5) of this Section.

[Sec. 209 amended by EO 12086 of Oct. 5, 1978, 43 FR 46501, 3 CFR, 1978 Comp., p. 230]

**SEC. 210.** Whenever the Secretary of Labor makes a determination under Section 209, the Secretary shall promptly notify the appropriate agency. The agency shall take the action directed by the Secretary and shall report the results of the action it has taken to the Secretary of Labor within such time as the Secretary shall specify. If the contracting agency fails to take the action directed within thirty days, the Secretary may take the action directly.

[Sec. 210 amended by EO 12086 of Oct. 5, 1978, 43 FR 46501, 3 CFR, 1978 Comp., p. 230]

**SEC. 211.** If the Secretary shall so direct, contracting agencies shall not enter into contracts with any bidder or prospective contractor unless the bidder or prospective contractor has satisfactorily complied with the provisions of this Order or submits a program for compliance acceptable to the Secretary of Labor.

[Sec. 211 amended by EO 12086 of Oct. 5, 1978, 43 FR 46501, 3 CFR, 1978 Comp., p. 230]

**SEC. 212.** When a contract has been cancelled or terminated under Section 209(a)(5) or a contractor has been debarred from further Government contracts under Section 209(a)(6) of this Order, because of noncompliance with the contract provisions specified in Section 202 of this Order, the Secretary of Labor shall promptly notify the Comptroller General of the United States.

[Sec. 212 amended by EO 12086 of Oct. 5, 1978, 43 FR 46501, 3 CFR, 1978 Comp., p. 230]

#### **Subpart E - Certificates of Merit**

**SEC. 213.** The Secretary of Labor may provide for issuance of a United States Government Certificate of Merit to employers or labor unions, or other agencies which are or may hereafter be engaged in work under Government contracts, if the Secretary is satisfied that the personnel and employment practices of the employer, or that the personnel, training, apprenticeship, membership, grievance and representation, upgrading, and other practices and policies of the labor union or other agency conform to the purposes and provisions of this Order.

**SEC. 214.** Any Certificate of Merit may at any time be suspended or revoked by the Secretary of Labor if the holder thereof, in the judgment of the Secretary, has failed to comply with the provisions of this Order.

**SEC. 215.** The Secretary of Labor may provide for the exemption of any employer, labor union, or other agency from any reporting requirements imposed under or pursuant to this Order if such employer, labor union, or other agency has been awarded a Certificate of Merit which has not been suspended or revoked.

#### **Part III - Nondiscrimination Provisions in Federally Assisted Construction Contracts**

**SEC. 301.** Each executive department and agency, which administers a program involving Federal financial assistance shall require as a condition for the approval of any grant, contract, loan, insurance, or guarantee thereunder, which may involve a construction contract, that the applicant for Federal assistance undertake and agree to incorporate, or cause to be incorporated, into all construction contracts paid for in whole or in part with funds obtained from the Federal Government or borrowed on the credit of the Federal Government pursuant to such grant, contract, loan, insurance, or guarantee, or undertaken pursuant to any Federal program involving such grant, contract, loan, insurance, or guarantee, the provisions prescribed for Government contracts by Section 202 of this Order or such modification thereof, preserving in substance the contractor's obligations thereunder, as may be approved by the Secretary of Labor, together with such additional provisions as the Secretary deems appropriate to establish and protect the interest of the United States in the enforcement of those obligations. Each such applicant shall also undertake and agree (1) to assist and cooperate actively with the Secretary of Labor in obtaining the compliance of contractors and

subcontractors with those contract provisions and with the rules, regulations and relevant orders of the Secretary, (2) to obtain and to furnish to the Secretary of Labor such information as the Secretary may require for the supervision of such compliance, (3) to carry out sanctions and penalties for violation of such obligations imposed upon contractors and subcontractors by the Secretary of Labor pursuant to Part II, Subpart D, of this Order, and (4) to refrain from entering into any contract subject to this Order, or extension or other modification of such a contract with a contractor debarred from Government contracts under Part II, Subpart D, of this Order.

[Sec. 301 amended by EO 12086 of Oct. 5, 1978, 43 FR 46501, 3 CFR, 1978 Comp., p. 230]

#### **SEC. 302.**

- a. "Construction contract" as used in this Order means any contract for the construction, rehabilitation, alteration, conversion, extension, or repair of buildings, highways, or other improvements to real property.
- b. The provisions of Part II of this Order shall apply to such construction contracts, and for purposes of such application the administering department or agency shall be considered the contracting agency referred to therein.
- c. The term "applicant" as used in this Order means an applicant for Federal assistance or, as determined by agency regulation, other program participant, with respect to whom an application for any grant, contract, loan, insurance, or guarantee is not finally acted upon prior to the effective date of this Part, and it includes such an applicant after he/she becomes a recipient of such Federal assistance.

#### **SEC. 303.**

- a. The Secretary of Labor shall be responsible for obtaining the compliance of such applicants with their undertakings under this Order. Each administering department and agency is directed to cooperate with the Secretary of Labor and to furnish the Secretary such information and assistance as the Secretary may require in the performance of the Secretary's functions under this Order.
- b. In the event an applicant fails and refuses to comply with the applicant's undertakings pursuant to this Order, the Secretary of Labor may, after consulting with the administering department or agency, take any or all of the following actions: (1) direct any administering department or agency to cancel, terminate, or suspend in whole or in part the agreement, contract or other arrangement with such applicant with respect to which the failure or refusal occurred; (2) direct any administering department or agency to refrain from extending any further assistance to the applicant under the program with respect to which the failure or refusal occurred until satisfactory assurance of future compliance has been received by the Secretary of Labor from such applicant; and (3) refer the case to the Department of Justice or the Equal Employment Opportunity Commission for appropriate law enforcement or other proceedings.
- c. In no case shall action be taken with respect to an applicant pursuant to clause (1) or (2) of subsection (b) without notice and opportunity for hearing.

[Sec. 303 amended by EO 12086 of Oct. 5, 1978, 43 FR 46501, 3 CFR, 1978 Comp., p. 230]

**SEC. 304.** Any executive department or agency which imposes by rule, regulation, or order requirements of nondiscrimination in employment, other than requirements imposed pursuant to this Order, may delegate to the Secretary of Labor by agreement such responsibilities with respect to compliance standards, reports, and procedures as would tend to bring the administration of such requirements into conformity with the administration of requirements imposed under this Order: Provided, That actions to effect compliance by recipients of Federal financial assistance with requirements imposed pursuant to Title VI of the Civil Rights Act of 1964 shall be taken in conformity with the procedures and limitations prescribed in Section 602 thereof and the regulations of the administering department or agency issued thereunder.

#### **Part IV - Miscellaneous**

**SEC. 401.** The Secretary of Labor may delegate to any officer, agency, or employee in the Executive branch of the Government, any function or duty of the Secretary under Parts II and III of this Order.

[Sec. 401 amended by EO 12086 of Oct. 5, 1978, 43 FR 46501, 3 CFR, 1978 Comp., p. 230]

**SEC. 402.** The Secretary of Labor shall provide administrative support for the execution of the program known as the "Plans for Progress."

**SEC. 403.**

- a. Executive Orders Nos. 10590 (January 19, 1955), 10722 (August 5, 1957), 10925 (March 6, 1961), 11114 (June 22, 1963), and 11162 (July 28, 1964), are hereby superseded and the President's Committee on Equal Employment Opportunity established by Executive Order No. 10925 is hereby abolished. All records and property in the custody of the Committee shall be transferred to the Office of Personnel Management and the Secretary of Labor, as appropriate.
- b. Nothing in this Order shall be deemed to relieve any person of any obligation assumed or imposed under or pursuant to any Executive Order superseded by this Order. All rules, regulations, orders, instructions, designations, and other directives issued by the President's Committee on Equal Employment Opportunity and those issued by the heads of various departments or agencies under or pursuant to any of the Executive orders superseded by this Order, shall, to the extent that they are not inconsistent with this Order, remain in full force and effect unless and until revoked or superseded by appropriate authority. References in such directives to provisions of the superseded orders shall be deemed to be references to the comparable provisions of this Order.

[Sec. 403 amended by EO 12107 of Dec. 28, 1978, 44 FR 1055, 3 CFR, 1978 Comp., p. 264]

**SEC. 404.** The General Services Administration shall take appropriate action to revise the standard Government contract forms to accord with the provisions of this Order and of the rules and regulations of the Secretary of Labor.

**SEC. 405.** This Order shall become effective thirty days after the date of this Order.



**41 CFR 60-1.4(B)**  
**Equal Opportunity Clause**

(b) *Federally assisted construction contracts.* (1) Except as otherwise provided, each administering agency shall require the inclusion of the following language as a condition of any grant, contract, loan, insurance, or guarantee involving federally assisted construction which is not exempt from the requirements of the equal opportunity clause:

The applicant hereby agrees that it will incorporate or cause to be incorporated into any contract for construction work, or modification thereof, as defined in the regulations of the Secretary of Labor at 41 CFR Chapter 60, which is paid for in whole or in part with funds obtained from the Federal Government or borrowed on the credit of the Federal Government pursuant to a grant, contract, loan, insurance, or guarantee, or undertaken pursuant to any Federal program involving such grant, contract, loan, insurance, or guarantee, the following equal opportunity clause:

During the performance of this contract, the contractor agrees as follows:

(1) The contractor will not discriminate against any employee or applicant for employment because of race, color, religion, sex, sexual orientation, gender identity, or national origin. The contractor will take affirmative action to ensure that applicants are employed, and that employees are treated during employment without regard to their race, color, religion, sex, sexual orientation, gender identity, or national origin. Such action shall include, but not be limited to the following:

Employment, upgrading, demotion, or transfer; recruitment or recruitment advertising; layoff or termination; rates of pay or other forms of compensation; and selection for training, including apprenticeship. The contractor agrees to post in conspicuous places, available to employees and applicants for employment, notices to be provided setting forth the provisions of this nondiscrimination clause.

(2) The contractor will, in all solicitations or advertisements for employees placed by or on behalf of the contractor, state that all qualified applicants will receive consideration for employment without regard to race, color, religion, sex, sexual orientation, gender identity, or national origin.

(3) The contractor will not discharge or in any other manner discriminate against any employee or applicant for employment because such employee or applicant has inquired about, discussed, or disclosed the compensation of the employee or applicant or another employee or applicant. This provision shall not apply to instances in which an employee who has access to the compensation information of other employees or applicants as a part of such employee's essential job functions discloses the compensation of such other employees or applicants to individuals who do not otherwise have access to such information, unless such disclosure is in response to a formal complaint or charge, in furtherance of an investigation, proceeding, hearing, or action, including an investigation conducted by the employer, or is consistent with the contractor's legal duty to furnish information.

(4) The contractor will send to each labor union or representative of workers with which he has a collective bargaining agreement or other contract or understanding, a notice to be provided advising the said labor union or workers' representatives of the contractor's commitments under this section, and shall post copies of the notice in conspicuous places available to employees and applicants for employment.

(5) The contractor will comply with all provisions of Executive Order 11246 of September 24, 1965, and of the rules, regulations, and relevant orders of the Secretary of Labor.

(6) The contractor will furnish all information and reports required by Executive Order 11246 of September 24, 1965, and by rules, regulations, and orders of the Secretary of Labor, or pursuant thereto, and will permit access to his books, records, and accounts by the administering agency and the Secretary of Labor for purposes of investigation to ascertain compliance with such rules, regulations, and orders.

(7) In the event of the contractor's noncompliance with the nondiscrimination clauses of this contract or with any of the said rules, regulations, or orders, this contract may be canceled, terminated, or suspended in whole or in part and the contractor may be declared ineligible for further Government contracts or federally assisted construction

contracts in accordance with procedures authorized in Executive Order 11246 of September 24, 1965, and such other sanctions may be imposed and remedies invoked as provided in Executive Order 11246 of September 24, 1965, or by rule, regulation, or order of the Secretary of Labor, or as otherwise provided by law.

(8) The contractor will include the portion of the sentence immediately preceding paragraph (1) and the provisions of paragraphs (1) through (8) in every subcontract or purchase order unless exempted by rules, regulations, or orders of the Secretary of Labor issued pursuant to section 204 of Executive Order 11246 of September 24, 1965, so that such provisions will be binding upon each subcontractor or vendor. The contractor will take such action with respect to any subcontract or purchase order as the administering agency may direct as a means of enforcing such provisions, including sanctions for noncompliance:

Provided, however, that in the event a contractor becomes involved in, or is threatened with, litigation with a subcontractor or vendor as a result of such direction by the administering agency, the contractor may request the United States to enter into such litigation to protect the interests of the United States.

The applicant further agrees that it will be bound by the above equal opportunity clause with respect to its own employment practices when it participates in federally assisted construction work: *Provided*, That if the applicant so participating is a State or local government, the above equal opportunity clause is not applicable to any agency, instrumentality or subdivision of such government which does not participate in work on or under the contract.

The applicant agrees that it will assist and cooperate actively with the administering agency and the Secretary of Labor in obtaining the compliance of contractors and subcontractors with the equal opportunity clause and the rules, regulations, and relevant orders of the Secretary of Labor, that it will furnish the administering agency and the Secretary of Labor such information as they may require for the supervision of such compliance, and that it will otherwise assist the administering agency in the discharge of the agency's primary responsibility for securing compliance.

The applicant further agrees that it will refrain from entering into any contract or contract modification subject to Executive Order 11246 of September 24, 1965, with a contractor debarred from, or who has not demonstrated eligibility for, Government contracts and federally assisted construction contracts pursuant to the Executive Order and will carry out such sanctions and penalties for violation of the equal opportunity clause as may be imposed upon contractors and subcontractors by the administering agency or the Secretary of Labor pursuant to Part II, Subpart D of the Executive Order. In addition, the applicant agrees that if it fails or refuses to comply with these undertakings, the administering agency may take any or all of the following actions: Cancel, terminate, or suspend in whole or in part this grant (contract, loan, insurance, guarantee); refrain from extending any further assistance to the applicant under the program with respect to which the failure or refund occurred until satisfactory assurance of future compliance has been received from such applicant; and refer the case to the Department of Justice for appropriate legal proceedings.

(2) [Reserved]

## 41 CFR 60-4.3

### STANDARD FEDERAL EQUAL OPPORTUNITY CONSTRUCTION CONTRACT SPECIFICATIONS

(a) The equal opportunity clause published at 41 CFR 60-1.4(a) of this chapter is required to be included in, and is part of, all nonexempt Federal contracts and subcontracts, including construction contracts and subcontracts. The equal opportunity clause published at 41 CFR 60-1.4(b) is required to be included in, and is a part of, all nonexempt federally assisted construction contracts and subcontracts. In addition to the clauses described above, all Federal contracting officers, all applicants and all nonconstruction contractors, as applicable, shall include the specifications set forth in this section in all Federal and federally assisted construction contracts in excess of \$10,000 to be performed in geographical areas designated by the Director pursuant to §60-4.6 of this part and in construction subcontracts in excess of \$10,000 necessary in whole or in part to the performance of nonconstruction Federal contracts and subcontracts covered under the Executive order.

### STANDARD FEDERAL EQUAL EMPLOYMENT OPPORTUNITY CONSTRUCTION CONTRACT SPECIFICATIONS (EXECUTIVE ORDER 11246)

1. As used in these specifications:

a. "Covered area" means the geographical area described in the solicitation from which this contract resulted;

b. "Director" means Director, Office of Federal Contract Compliance Programs, United States Department of Labor, or any person to whom the Director delegates authority;

c. "Employer identification number" means the Federal Social Security number used on the Employer's Quarterly Federal Tax Return, U.S. Treasury Department Form 941.

d. "Minority" includes:

(i) Black (all persons having origins in any of the Black African racial groups not of Hispanic origin);

(ii) Hispanic (all persons of Mexican, Puerto Rican, Cuban, Central or South American or other Spanish Culture or origin, regardless of race);

(iii) Asian and Pacific Islander (all persons having origins in any of the original peoples of the Far East, Southeast Asia, the Indian Subcontinent, or the Pacific Islands); and

(iv) American Indian or Alaskan Native (all persons having origins in any of the original peoples of North America and maintaining identifiable tribal affiliations through membership and participation or community identification).

2. Whenever the Contractor, or any Subcontractor at any tier, subcontracts a portion of the work involving any construction trade, it shall physically include in each subcontract in excess of \$10,000 the provisions of these specifications and the Notice which contains the applicable goals for minority and female participation and which is set forth in the solicitations from which this contract resulted.

3. If the Contractor is participating (pursuant to 41 CFR 60-4.5) in a Hometown Plan approved by the U.S. Department of Labor in the covered area either individually or through an association, its affirmative action obligations on all work in the Plan area (including goals and timetables) shall be in accordance with that Plan for those trades which have unions participating in the Plan. Contractors must be able to demonstrate their participation in and compliance with the provisions of any such Hometown Plan. Each Contractor or Subcontractor participating in an approved Plan is individually required to comply with its obligations under the EEO clause, and to make a good faith effort to achieve each goal under the Plan in each trade in which it has employees. The overall good faith

performance by other Contractors or Subcontractors toward a goal in an approved Plan does not excuse any covered Contractor's or Subcontractor's failure to take good faith efforts to achieve the Plan goals and timetables.

4. The Contractor shall implement the specific affirmative action standards provided in paragraphs 7 a through p of these specifications. The goals set forth in the solicitation from which this contract resulted are expressed as percentages of the total hours of employment and training of minority and female utilization the Contractor should reasonably be able to achieve in each construction trade in which it has employees in the covered area. Covered Construction contractors performing construction work in geographical areas where they do not have a Federal or federally assisted construction contract shall apply the minority and female goals established for the geographical area where the work is being performed. Goals are published periodically in the FEDERAL REGISTER in notice form, and such notices may be obtained from any Office of Federal Contract Compliance Programs office or from Federal procurement contracting officers. The Contractor is expected to make substantially uniform progress in meeting its goals in each craft during the period specified.

5. Neither the provisions of any collective bargaining agreement, nor the failure by a union with whom the Contractor has a collective bargaining agreement, to refer either minorities or women shall excuse the Contractor's obligations under these specifications, Executive Order 11246, or the regulations promulgated pursuant thereto.

6. In order for the nonworking training hours of apprentices and trainees to be counted in meeting the goals, such apprentices and trainees must be employed by the Contractor during the training period, and the Contractor must have made a commitment to employ the apprentices and trainees at the completion of their training, subject to the availability of employment opportunities. Trainees must be trained pursuant to training programs approved by the U.S. Department of Labor.

7. The Contractor shall take specific affirmative actions to ensure equal employment opportunity. The evaluation of the Contractor's compliance with these specifications shall be based upon its effort to achieve maximum results from its actions. The Contractor shall document these efforts fully, and shall implement affirmative action steps at least as extensive as the following:

a. Ensure and maintain a working environment free of harassment, intimidation, and coercion at all sites, and in all facilities at which the Contractor's employees are assigned to work. The Contractor, where possible, will assign two or more women to each construction project. The Contractor shall specifically ensure that all foremen, superintendents, and other on-site supervisory personnel are aware of and carry out the Contractor's obligation to maintain such a working environment, with specific attention to minority or female individuals working at such sites or in such facilities.

b. Establish and maintain a current list of minority and female recruitment sources, provide written notification to minority and female recruitment sources and to community organizations when the Contractor or its unions have employment opportunities available, and maintain a record of the organizations' responses.

c. Maintain a current file of the names, addresses and telephone numbers of each minority and female off-the-street applicant and minority or female referral from a union, a recruitment source or community organization and of what action was taken with respect to each such individual. If such individual was sent to the union hiring hall for referral and was not referred back to the Contractor by the union or, if referred, not employed by the Contractor, this shall be documented in the file with the reason therefor, along with whatever additional actions the Contractor may have taken.

d. Provide immediate written notification to the Director when the union or unions with which the Contractor has a collective bargaining agreement has not referred to the Contractor a minority person or woman sent by the Contractor, or when the Contractor has other information that the union referral process has impeded the Contractor's efforts to meet its obligations.

e. Develop on-the-job training opportunities and/or participate in training programs for the area which expressly include minorities and women, including upgrading programs and apprenticeship and trainee programs relevant to the Contractor's employment needs, especially those programs funded or approved by the Department of Labor. The Contractor shall provide notice of these programs to the sources compiled under 7b above.

f. Disseminate the Contractor's EEO policy by providing notice of the policy to unions and training programs and requesting their cooperation in assisting the Contractor in meeting its EEO obligations; by including it in any

policy manual and collective bargaining agreement; by publicizing it in the company newspaper, annual report, etc.; by specific review of the policy with all management personnel and with all minority and female employees at least once a year; and by posting the company EEO policy on bulletin boards accessible to all employees at each location where construction work is performed.

g. Review, at least annually, the company's EEO policy and affirmative action obligations under these specifications with all employees having any responsibility for hiring, assignment, layoff, termination or other employment decisions including specific review of these items with onsite supervisory personnel such as Superintendents, General Foremen, etc., prior to the initiation of construction work at any job site. A written record shall be made and maintained identifying the time and place of these meetings, persons attending, subject matter discussed, and disposition of the subject matter.

h. Disseminate the Contractor's EEO policy externally by including it in any advertising in the news media, specifically including minority and female news media, and providing written notification to and discussing the Contractor's EEO policy with other Contractors and Subcontractors with whom the Contractor does or anticipates doing business.

i. Direct its recruitment efforts, both oral and written, to minority, female and community organizations, to schools with minority and female students and to minority and female recruitment and training organizations serving the Contractor's recruitment area and employment needs. Not later than one month prior to the date for the acceptance of applications for apprenticeship or other training by any recruitment source, the Contractor shall send written notification to organizations such as the above, describing the openings, screening procedures, and tests to be used in the selection process.

j. Encourage present minority and female employees to recruit other minority persons and women and, where reasonable, provide after school, summer and vacation employment to minority and female youth both on the site and in other areas of a Contractor's work force.

k. Validate all tests and other selection requirements where there is an obligation to do so under 41 CFR part 60-3.

l. Conduct, at least annually, an inventory and evaluation at least of all minority and female personnel for promotional opportunities and encourage these employees to seek or to prepare for, through appropriate training, etc., such opportunities.

m. Ensure that seniority practices, job classifications, work assignments and other personnel practices, do not have a discriminatory effect by continually monitoring all personnel and employment related activities to ensure that the EEO policy and the Contractor's obligations under these specifications are being carried out.

n. Ensure that all facilities and company activities are nonsegregated except that separate or single-user toilet and necessary changing facilities shall be provided to assure privacy between the sexes.

o. Document and maintain a record of all solicitations of offers for subcontracts from minority and female construction contractors and suppliers, including circulation of solicitations to minority and female contractor associations and other business associations.

p. Conduct a review, at least annually, of all supervisors' adherence to and performance under the Contractor's EEO policies and affirmative action obligations.

8. Contractors are encouraged to participate in voluntary associations which assist in fulfilling one or more of their affirmative action obligations (7a through p). The efforts of a contractor association, joint contractor-union, contractor-community, or other similar group of which the contractor is a member and participant, may be asserted as fulfilling any one or more of its obligations under 7a through p of these Specifications provided that the contractor actively participates in the group, makes every effort to assure that the group has a positive impact on the employment of minorities and women in the industry, ensures that the concrete benefits of the program are reflected in the Contractor's minority and female workforce participation, makes a good faith effort to meet its individual goals and timetables, and can provide access to documentation which demonstrates the effectiveness of actions taken on

behalf of the Contractor. The obligation to comply, however, is the Contractor's and failure of such a group to fulfill an obligation shall not be a defense for the Contractor's noncompliance.

9. A single goal for minorities and a separate single goal for women have been established. The Contractor, however, is required to provide equal employment opportunity and to take affirmative action for all minority groups, both male and female, and all women, both minority and non-minority. Consequently, the Contractor may be in violation of the Executive Order if a particular group is employed in a substantially disparate manner (for example, even though the Contractor has achieved its goals for women generally, the Contractor may be in violation of the Executive Order if a specific minority group of women is underutilized).

10. The Contractor shall not use the goals and timetables or affirmative action standards to discriminate against any person because of race, color, religion, sex, sexual orientation, gender identity, or national origin.

11. The Contractor shall not enter into any Subcontract with any person or firm debarred from Government contracts pursuant to Executive Order 11246.

12. The Contractor shall carry out such sanctions and penalties for violation of these specifications and of the Equal Opportunity Clause, including suspension, termination and cancellation of existing subcontracts as may be imposed or ordered pursuant to Executive Order 11246, as amended, and its implementing regulations, by the Office of Federal Contract Compliance Programs. Any Contractor who fails to carry out such sanctions and penalties shall be in violation of these specifications and Executive Order 11246, as amended.

13. The Contractor, in fulfilling its obligations under these specifications, shall implement specific affirmative action steps, at least as extensive as those standards prescribed in paragraph 7 of these specifications, so as to achieve maximum results from its efforts to ensure equal employment opportunity. If the Contractor fails to comply with the requirements of the Executive Order, the implementing regulations, or these specifications, the Director shall proceed in accordance with 41 CFR 60-4.8.

14. The Contractor shall designate a responsible official to monitor all employment related activity to ensure that the company EEO policy is being carried out, to submit reports relating to the provisions hereof as may be required by the Government and to keep records. Records shall at least include for each employee the name, address, telephone numbers, construction trade, union affiliation if any, employee identification number when assigned, social security number, race, sex, status (e.g., mechanic, apprentice trainee, helper, or laborer), dates of changes in status, hours worked per week in the indicated trade, rate of pay, and locations at which the work was performed. Records shall be maintained in an easily understandable and retrievable form; however, to the degree that existing records satisfy this requirement, contractors shall not be required to maintain separate records.

15. Nothing herein provided shall be construed as a limitation upon the application of other laws which establish different standards of compliance or upon the application of requirements for the hiring of local or other area residents (e.g., those under the Public Works Employment Act of 1977 and the Community Development Block Grant Program).

(b) The notice set forth in 41 CFR 60-4.2 and the specifications set forth in 41 CFR 60-4.3 replace the New Form for Federal Equal Employment Opportunity Bid Conditions for Federal and Federally Assisted Construction published at 41 FR 32482 and commonly known as the Model Federal EEO Bid Conditions, and the New Form shall not be used after the regulations in 41 CFR part 60-4 become effective.

[43 FR 49254, Oct. 20, 1978; 43 FR 51401, Nov. 3, 1978, as amended at 45 FR 65978, Oct. 3, 1980; 79 FR 72995, Dec. 9, 2014]

NOTICE OF REQUIREMENT FOR AFFIRMATIVE ACTION TO ENSURE  
EQUAL EMPLOYMENT OPPORTUNITY  
Executive Order 11246:41CFR Part 60-2

1. The Offeror's or Bidder's attention is called to the "Equal Opportunity Clause" and the "Standard Federal Equal Employment Specifications" set forth herein.

2. The goals and timetables for minority and female participation, expressed in percentage terms for the Contractor's aggregate workforce in each trade on all construction work in the covered area, are as follows:

<b>Time- tables</b>	<b>Goals for minority participation for each trade</b>	<b>Goals for female participation in each trade</b>
	4.5%	6.9%

These goals are applicable to all the Contractor's construction work (whether or not it is Federal or federally assisted) performed in the covered area. If the contractor performs construction work in a geographical area located outside of the covered area, it shall apply the goals established for such geographical area where the work is actually performed. With regard to this second area, the contractor also is subject to the goals for both its federally involved and non-federally involved construction.

The Contractor's compliance with the Executive Order and the regulations in 41 CFR part 60-4 shall be based on its implementation of the Equal Opportunity Clause, specific affirmative action obligations required by the specifications set forth in 41 CFR 60-4.3(a), and its efforts to meet the goals. The hours of minority and female employment and training must be substantially uniform throughout the length of the contract, and in each trade, and the contractor shall make a good faith effort to employ minorities and women evenly on each of its projects. The transfer of minority or female employees or trainees from Contractor to Contractor or from project to project for the sole purpose of meeting the Contractor's goals shall be a violation of the contract, the Executive Order and the regulations in 41 CFR part 60-4. Compliance with the goals will be measured against the total work hours performed.

3. The Contractor shall provide written notification to the Director of the Office of Federal Contract Compliance Programs within 10 working days of award of any construction subcontract in excess of \$10,000 at any tier for construction work under the contract resulting from this solicitation. The notification shall list the name, address and telephone number of the subcontractor; employer identification number of the subcontractor; estimated dollar amount of the subcontract; estimated starting and completion dates of the subcontract; and the geographical area in which the subcontract is to be performed.

4. As used in this Notice, and in the contract resulting from this solicitation, the "covered area" is (insert description of the geographical areas where the contract is to be performed giving the state, county and city, if any).

## Wage and Hour Division (WHD)

### **Copeland "Anti-kickback" Act**

#### **TITLE 18, U.S.C.**

##### **Sec. 874. Kickbacks from public works employees**

Whoever, by force, intimidation, or threat of procuring dismissal from employment, or by any other manner whatsoever induces any person employed in the construction, prosecution, completion or repair of any public building, public work, or building or work financed in whole or in part by loans or grants from the United States, to give up any part of the compensation to which he is entitled under his contract of employment, shall be fined under this title or imprisoned not more than five years, or both.

[18 U.S.C. 874 (June 25, 1948, ch. 645, Sec. 1, 62 Stat. 740 and 862, eff. Sept. 1, 1948) replaced the former sec. 1 of the Copeland Act of June 13, 1934 (48 Stat. 948). Prior to 1948, Section 1 of the Copeland Act was codified as 40 U.S.C. 276b. P.L. 103-322, (Sept. 13, 1994, 108 Stat. 2147), substituted "fined under this title" for "fined not more than \$5,000".]

#### **TITLE 40, U.S.C.**

##### **Sec. 3145. Regulations governing contractors and subcontractors**

(a) In General.—The Secretary of Labor shall prescribe reasonable regulations for contractors and subcontractors engaged in constructing, carrying out, completing, or repairing public buildings, public works, or buildings or works that at least partly are financed by a loan or grant from the Federal Government. The regulations shall include a provision that each contractor and subcontractor each week must furnish a statement on the wages paid each employee during the prior week.

(b) Application.—Section 1001 of title 18 applies to the statements.

[Section 2 of the original Act of June 13, 1934, as amended prior to 2002, and codified as 40 U.S.C. 276c, was repealed, revised and codified as 40 U.S.C. 3145 by P.L. 107-217 (Aug. 21, 2002, 116 Stat. 1152, 1304, 1309, 1313, 1315).]

*See also:* [Reorganization Plan No. 14 of 1950](#) (15 F.R. 3176, 64 Stat. 1267, 5 U.S.C. 133z note)

Deduction request letters may now be submitted electronically. Simply scan a copy of the signed request and email your request to [dbadeductions@dol.gov](mailto:dbadeductions@dol.gov). The email address may also be used to request the status of current deduction requests as well as to ask technical assistance questions regarding Copeland Act deductions.



## 29 CFR Part 3

### PART 3—CONTRACTORS AND SUBCONTRACTORS ON PUBLIC BUILDING OR PUBLIC WORK FINANCED IN WHOLE OR IN PART BY LOANS OR GRANTS FROM THE UNITED STATES

#### §3.1 Purpose and scope.

This part prescribes “anti-kickback” regulations under section 2 of the Act of June 13, 1934, as amended (40 U.S.C. 276c), popularly known as the Copeland Act. This part applies to any contract which is subject to Federal wage standards and which is for the construction, prosecution, completion, or repair of public buildings, public works or buildings or works financed in whole or in part by loans or grants from the United States. The part is intended to aid in the enforcement of the minimum wage provisions of the Davis-Bacon Act and the various statutes dealing with federally assisted construction that contain similar minimum wage provisions, including those provisions which are not subject to Reorganization Plan No. 14 (e.g., the College Housing Act of 1950, the Federal Water Pollution Control Act, and the Housing Act of 1959), and in the enforcement of the overtime provisions of the Contract Work Hours Standards Act whenever they are applicable to construction work. The part details the obligation of contractors and subcontractors relative to the weekly submission of statements regarding the wages paid on work covered thereby; sets forth the circumstances and procedures governing the making of payroll deductions from the wages of those employed on such work; and delineates the methods of payment permissible on such work.

#### §3.2 Definitions.

As used in the regulations in this part:

(a) The terms *building* or *work* generally include construction activity as distinguished from manufacturing, furnishing of materials, or servicing and maintenance work. The terms include, without limitation, buildings, structures, and improvements of all types, such as bridges, dams, plants, highways, parkways, streets, subways, tunnels, sewers, mains, powerlines, pumping stations, railways, airports, terminals, docks, piers, wharves, ways, lighthouses, buoys, jetties, breakwaters, levees, and canals; dredging, shoring, scaffolding, drilling, blasting, excavating, clearing, and landscaping. Unless conducted in connection with and at the site of such a building or work as is described in the foregoing sentence, the manufacture or furnishing of materials, articles, supplies, or equipment (whether or not a Federal or State agency acquires title to such materials, articles, supplies, or equipment during the course of the manufacture or furnishing, or owns the materials from which they are manufactured or furnished) is not a *building* or *work* within the meaning of the regulations in this part.

(b) The terms *construction*, *prosecution*, *completion*, or *repair* mean all types of work done on a particular building or work at the site thereof, including, without limitation, altering, remodeling, painting and decorating, the transporting of materials and supplies to or from the building or work by the employees of the construction contractor or construction subcontractor, and the manufacturing or furnishing of materials, articles, supplies, or equipment on the site of the building or work, by persons employed at the site by the contractor or subcontractor.

(c) The terms *public building* or *public work* include building or work for whose construction, prosecution, completion, or repair, as defined above, a Federal agency is a contracting party, regardless of whether title thereof is in a Federal agency.

(d) The term *building or work financed in whole or in part by loans or grants from the United States* includes building or work for whose construction, prosecution, completion, or repair, as defined above, payment or part payment is made directly or indirectly from funds provided by loans or grants by a Federal agency. The term includes building or work for which the Federal assistance granted is in the form of loan guarantees or insurance.

(e) Every person paid by a contractor or subcontractor in any manner for his labor in the construction, prosecution, completion, or repair of a public building or public work or building or work financed in whole or in part by loans or grants from the United States is *employed* and receiving *wages*, regardless of any contractual relationship alleged to exist between him and the real employer.

(f) The term *any affiliated person* includes a spouse, child, parent, or other close relative of the contractor or subcontractor; a partner or officer of the contractor or subcontractor; a corporation closely connected with the contractor or subcontractor as parent, subsidiary, or otherwise, and an officer or agent of such corporation.

(g) The term *Federal agency* means the United States, the District of Columbia, and all executive departments, independent establishments, administrative agencies, and instrumentalities of the United States and of the District of Columbia, including corporations, all or substantially all of the stock of which is beneficially owned by the United States, by the District of Columbia, or any of the foregoing departments, establishments, agencies, and instrumentalities.

[29 FR 97, Jan. 4, 1964, as amended at 38 FR 32575, Nov. 27, 1973]

 [Back to Top](#)

### **§3.3 Weekly statement with respect to payment of wages.**

(a) As used in this section, the term *employee* shall not apply to persons in classifications higher than that of laborer or mechanic and those who are the immediate supervisors of such employees.

(b) Each contractor or subcontractor engaged in the construction, prosecution, completion, or repair of any public building or public work, or building or work financed in whole or in part by loans or grants from the United States, shall furnish each week a statement with respect to the wages paid each of its employees engaged on work covered by this part 3 and part 5 of this title during the preceding weekly payroll period. This statement shall be executed by the contractor or subcontractor or by an authorized officer or employee of the contractor or subcontractor who supervises the payment of wages, and shall be on the back of Form WH 347, "Payroll (For Contractors Optional Use)" or on any form with identical wording. Copies of Form WH 347 may be obtained from the Government contracting or sponsoring agency or from the Wage and Hour Division Web site at <http://www.dol.gov/esa/whd/forms/wh347instr.htm> or its successor site.

(c) The requirements of this section shall not apply to any contract of \$2,000 or less.

(d) Upon a written finding by the head of a Federal agency, the Secretary of Labor may provide reasonable limitations, variations, tolerances, and exemptions from the requirements of this section subject to such conditions as the Secretary of Labor may specify.

[29 FR 97, Jan. 4, 1964, as amended at 33 FR 10186, July 17, 1968; 47 FR 23679, May 28, 1982; 73 FR 77511, Dec. 19, 2008]

### **§3.4 Submission of weekly statements and the preservation and inspection of weekly payroll records.**

(a) Each weekly statement required under §3.3 shall be delivered by the contractor or subcontractor, within seven days after the regular payment date of the payroll period, to a representative of a Federal or State agency in charge at the site of the building or work, or, if there is no representative of a Federal or State agency at the site of the building or work, the statement shall be mailed by the contractor or subcontractor, within such time, to a Federal or State agency contracting for or financing the building or work. After such examination and check as may be made, such statement, or a copy thereof, shall be kept available, or shall be transmitted together with a report of any violation, in accordance with applicable procedures prescribed by the United States Department of Labor.

(b) Each contractor or subcontractor shall preserve his weekly payroll records for a period of three years from date of completion of the contract. The payroll records shall set out accurately and completely the name and address of each laborer and mechanic, his correct classification, rate of pay, daily and weekly number of hours worked, deductions made, and actual wages paid. Such payroll records shall be made available at all times for inspection by the contracting officer or his authorized representative, and by authorized representatives of the Department of Labor.

(Reporting and recordkeeping requirements in paragraph (b) have been approved by the Office of Management and Budget under control number 1215-0017)

[29 FR 97, Jan. 4, 1964, as amended at 47 FR 145, Jan. 5, 1982]

### **§3.5 Payroll deductions permissible without application to or approval of the Secretary of Labor.**

Deductions made under the circumstances or in the situations described in the paragraphs of this section may be made without application to and approval of the Secretary of Labor:

(a) Any deduction made in compliance with the requirements of Federal, State, or local law, such as Federal or State withholding income taxes and Federal social security taxes.

(b) Any deduction of sums previously paid to the employee as a bona fide prepayment of wages when such prepayment is made without discount or interest. A *bona fide prepayment of wages* is considered to have been made only when cash or its equivalent has been advanced to the person employed in such manner as to give him complete freedom of disposition of the advanced funds.

(c) Any deduction of amounts required by court process to be paid to another, unless the deduction is in favor of the contractor, subcontractor, or any affiliated person, or when collusion or collaboration exists.

(d) Any deduction constituting a contribution on behalf of the person employed to funds established by the employer or representatives of employees, or both, for the purpose of providing either from principal or income, or both, medical or hospital care, pensions or annuities on retirement, death benefits, compensation for injuries, illness, accidents, sickness, or disability, or for insurance to provide any of the foregoing, or unemployment benefits, vacation pay, savings accounts, or similar payments for the benefit of employees, their families and dependents: *Provided, however,* That the following standards are met:

(1) The deduction is not otherwise prohibited by law;

(2) It is either:

(i) Voluntarily consented to by the employee in writing and in advance of the period in which the work is to be done and such consent is not a condition either for the obtaining of or for the continuation of employment, or

(ii) provided for in a bona fide collective bargaining agreement between the contractor or subcontractor and representatives of its employees;

(3) No profit or other benefit is otherwise obtained, directly or indirectly, by the contractor or subcontractor or any affiliated person in the form of commission, dividend, or otherwise; and

(4) The deductions shall serve the convenience and interest of the employee.

(e) Any deduction contributing toward the purchase of United States Defense Stamps and Bonds when voluntarily authorized by the employee.

(f) Any deduction requested by the employee to enable him to repay loans to or to purchase shares in credit unions organized and operated in accordance with Federal and State credit union statutes.

(g) Any deduction voluntarily authorized by the employee for the making of contributions to governmental or quasi-governmental agencies, such as the American Red Cross.

(h) Any deduction voluntarily authorized by the employee for the making of contributions to Community Chests, United Givers Funds, and similar charitable organizations.

(i) Any deductions to pay regular union initiation fees and membership dues, not including fines or special assessments: *Provided, however,* That a collective bargaining agreement between the contractor or subcontractor and representatives of its employees provides for such deductions and the deductions are not otherwise prohibited by law.

(j) Any deduction not more than for the "reasonable cost" of board, lodging, or other facilities meeting the requirements of section 3(m) of the Fair Labor Standards Act of 1938, as amended, and part 531 of this title. When such a deduction is made the additional records required under §516.25(a) of this title shall be kept.

(k) Any deduction for the cost of safety equipment of nominal value purchased by the employee as his own property for his personal protection in his work, such as safety shoes, safety glasses, safety gloves, and hard hats, if such equipment is not required by law to be furnished by the employer, if such deduction is not violative of the Fair Labor Standards Act or prohibited by other law, if the cost on which the deduction is based does not exceed the actual cost to the employer where the equipment is purchased from him and does not include any direct or indirect monetary return to the employer where the equipment is purchased from a third person, and if the deduction is either

(1) Voluntarily consented to by the employee in writing and in advance of the period in which the work is to be done and such consent is not a condition either for the obtaining of employment or its continuance; or

(2) Provided for in a bona fide collective bargaining agreement between the contractor or subcontractor and representatives of its employees.

[29 FR 97, Jan. 4, 1964, as amended at 36 FR 9770, May 28, 1971]

### **§3.6 Payroll deductions permissible with the approval of the Secretary of Labor.**

Any contractor or subcontractor may apply to the Secretary of Labor for permission to make any deduction not permitted under §3.5. The Secretary may grant permission whenever he finds that:

(a) The contractor, subcontractor, or any affiliated person does not make a profit or benefit directly or indirectly from the deduction either in the form of a commission, dividend, or otherwise;

(b) The deduction is not otherwise prohibited by law;

(c) The deduction is either (1) voluntarily consented to by the employee in writing and in advance of the period in which the work is to be done and such consent is not a condition either for the obtaining of employment or its continuance, or (2) provided for in a bona fide collective bargaining agreement between the contractor or subcontractor and representatives of its employees; and

(d) The deduction serves the convenience and interest of the employee.

### **§3.7 Applications for the approval of the Secretary of Labor.**

Any application for the making of payroll deductions under §3.6 shall comply with the requirements prescribed in the following paragraphs of this section:

(a) The application shall be in writing and shall be addressed to the Secretary of Labor.

(b) The application need not identify the contract or contracts under which the work in question is to be performed. Permission will be given for deductions on all current and future contracts of the applicant for a period of 1 year. A renewal of permission to make such payroll deduction will be granted upon the submission of an application which makes reference to the original application, recites the date of the Secretary of Labor's approval of such deductions, states affirmatively that there is continued compliance with the standards set forth in the provisions of §3.6, and specifies any conditions which have changed in regard to the payroll deductions.

(c) The application shall state affirmatively that there is compliance with the standards set forth in the provisions of §3.6. The affirmation shall be accompanied by a full statement of the facts indicating such compliance.

(d) The application shall include a description of the proposed deduction, the purpose to be served thereby, and the classes of laborers or mechanics from whose wages the proposed deduction would be made.

(e) The application shall state the name and business of any third person to whom any funds obtained from the proposed deductions are to be transmitted and the affiliation of such person, if any, with the applicant.

[29 FR 97, Jan. 4, 1964, as amended at 36 FR 9771, May 28, 1971]

### **§3.8 Action by the Secretary of Labor upon applications.**

The Secretary of Labor shall decide whether or not the requested deduction is permissible under provisions of §3.6; and shall notify the applicant in writing of his decision.

### **§3.9 Prohibited payroll deductions.**

Deductions not elsewhere provided for by this part and which are not found to be permissible under §3.6 are prohibited.

### **§3.10 Methods of payment of wages.**

The payment of wages shall be by cash, negotiable instruments payable on demand, or the additional forms of compensation for which deductions are permissible under this part. No other methods of payment shall be recognized on work subject to the Copeland Act.

**§3.11 Regulations part of contract.**

All contracts made with respect to the construction, prosecution, completion, or repair of any public building or public work or building or work financed in whole or in part by loans or grants from the United States covered by the regulations in this part shall expressly bind the contractor or subcontractor to comply with such of the regulations in this part as may be applicable. In this regard, see §5.5(a) of this subtitle.

# The Davis-Bacon Act, as Amended

---



U.S. Department of Labor  
Wage and Hour Division

WH Publication 1246  
(Revised April 2009)

Materials contained in this publication is in the public domain and may be reproduced, fully or partially, without permission of the federal Government. Source credit is requested but not required. Permission is required only to reproduce any copyrighted material contained herein.

This material will be made available to Sensory impaired individuals upon request.  
Voice phone: 202-693-0675  
TDD\* phone: 202-523-9530



An Act

To revise, codify, and enact without substantive change certain general and permanent laws, related to public buildings, property, and works, as title 40, United States Code, “Public Buildings, Property, and Works”.

*Be it enacted by the Senate and House of Representatives of the United States of America in Congress assembled,*

**SECTION 1. TITLE 40, UNITED STATES CODE.**

Certain general and permanent laws of the United States, related to public buildings, property, and works, are revised, codified, and enacted as title 40, United States Code, “Public Buildings, Property, and Works”, as follows:

**TITLE 40—PUBLIC BUILDINGS, PROPERTY, AND WORKS**

\* \* \* \*

**SUBTITLE II—PUBLIC BUILDINGS AND WORKS**

\* \* \* \*

**PART A—GENERAL**

\* \* \* \*

**CHAPTER 31 – GENERAL**

\* \* \* \*

**SUBCHAPTER IV - WAGE RATE REQUIREMENTS**

**Sec. 3141. Definition**

In this subchapter, the following definitions apply:

(1) Federal government.— The term “Federal Government” has the same meaning that the term “United States” had in the Act of March 3, 1931 (ch. 411, 46 Stat. 1494) (known as the Davis-Bacon Act).<sup>2</sup>

(2) Wages, scale of wages, wage rates, minimum wages, and prevailing wages.— The terms “wages”, “scale of wages”, “wage rates”, “minimum wages”, and “prevailing wages” include—

(A) the basic hourly rate of pay; and

<sup>1</sup>Pub. L. 109-284 Sec. 6(11), (12), and (13) made three minor technical corrections in Secs 3141(1), and 3142(d) and (e). (Sept. 27, 2006, 120 Stat.1213.)

<sup>2</sup>The Davis-Bacon Act, referred to in par. (1), is act of Mar. 3, 1931, ch. 411, 46 Stat. 1494, as amended, which was classified generally to sections 276a to 276a-5 of former Title 40, Public Buildings, Property, and Works, and was repealed and reenacted as sections 3141-3144, 3146, and 3147 of this title by Pub. L. 107-217, Secs. 1, 6(b), Aug. 21, 2002, 116 Stat. 1062, 1304.

(B) for medical or hospital care, pensions on retirement or death, compensation for injuries or illness resulting from occupational activity, or insurance to provide any of the foregoing, for unemployment benefits, life insurance, disability and sickness insurance, or accident insurance, for vacation and holiday pay, for defraying the costs of apprenticeship or other similar programs, or for other bona fide fringe benefits, but only where the contractor or subcontractor is not required by other federal, state, or local law to provide any of those benefits, the amount of—

(i) the rate of contribution irrevocably made by a contractor or subcontractor to a trustee or to a third person under a fund, plan, or program; and

(ii) the rate of costs to the contractor or subcontractor that may be reasonably anticipated in providing benefits to laborers and mechanics pursuant to an enforceable commitment to carry out a financially responsible plan or program which was communicated in writing to the laborers and mechanics affected.

### **Sec. 3142. Rate of wages for laborers and mechanics**

(a) Application.— The advertised specifications for every contract in excess of \$2,000, to which the Federal Government or the District of Columbia is a party, for construction, alteration, or repair, including painting and decorating, of public buildings and public works of the Government or the District of Columbia that are located in a State or the District of Columbia and which requires or involves the employment of mechanics or laborers shall contain a provision stating the minimum wages to be paid various classes of laborers and mechanics.

(b) Based on Prevailing Wage.— The minimum wages shall be based on the wages the Secretary of Labor determines to be prevailing for the corresponding classes of laborers and mechanics employed on projects of a character similar to the contract work in the civil subdivision of the State in which the work is to be performed, or in the District of Columbia if the work is to be performed there.

(c) Stipulations Required in Contract.— Every contract based upon the specifications referred to in subsection (a) must contain stipulations that—

(1) the contractor or subcontractor shall pay all mechanics and laborers employed directly on the site of the work, unconditionally and at least once a week, and without subsequent deduction or rebate on any account, the full amounts accrued at time of payment, computed at wage rates not less than those stated in the advertised specifications, regardless of any contractual relationship which may be alleged to exist between the contractor or subcontractor and the laborers and mechanics;

(2) the contractor will post the scale of wages to be paid in a prominent and easily accessible place at the site of the work; and

(3) there may be withheld from the contractor so much of accrued payments as the contracting officer considers necessary to pay to laborers and mechanics employed by the contractor or any subcontractor on the work the difference between the rates of wages required by the contract to be paid laborers and mechanics on the work and the rates of wages received by the laborers and mechanics and not refunded to the contractor or subcontractors or their agents.

(d) Discharge of Obligation.— The obligation of a contractor or subcontractor to make payment in accordance with the prevailing wage determinations of the Secretary of Labor, under this subchapter and other laws incorporating this subchapter by reference, may be discharged by making payments in cash, by making contributions described in section 3141(2)(B)(i) of this title, by assuming an enforceable commitment to bear the costs of a plan or program referred to in section 3141(2)(B)(ii) of this title, or by any combination of payment, contribution, and assumption, where the aggregate of the payments, contributions, and costs is not less than the basic hourly rate of pay plus the amount referred to in section 3141(2)(B) of this title.

(e) Overtime Pay.— In determining the overtime pay to which a laborer or mechanic is entitled under any federal law, the regular or basic hourly rate of pay (or other alternative rate on which premium rate of overtime compensation is computed) of the laborer or mechanic is deemed to be the rate computed under section 3141(2)(A) of this title, except that where the amount of payments, contributions, or costs incurred with respect to the laborer or mechanic exceeds the applicable prevailing wage, the regular or basic hourly rate of pay (or other alternative rate) is the amount of payments, contributions, or costs actually incurred with respect to the laborer or mechanic minus the greater of the amount of contributions or costs of the types described in section 3141(2)(B) of this title actually incurred with respect to the laborer or mechanic or the amount determined under section 3141(2)(B) of this title but not actually paid.

### **Sec. 3143.**

Every contract within the scope of this subchapter shall contain a provision that if the contracting officer finds that any laborer or mechanic employed by the contractor or any subcontractor directly on the site of the work covered by the contract has been or is being paid a rate of wages less than the rate of wages required by the contract to be paid, the Federal Government by written notice to the contractor may terminate the contractor's right to proceed with the work or the part of the work as to which there has been a failure to pay the required wages. The Government may have the work completed, by contract or otherwise, and the contractor and the contractor's sureties shall be liable to the Government for any excess costs the Government incurs.

### **Sec. 3144. Authority of Comptroller General to pay wages and list contractors violating contracts**

(a) Payment of Wages.—

(1) In general.— The Comptroller General shall pay directly to laborers and mechanics from any accrued payments withheld under the terms of a contract any wages found to be due laborers and mechanics under this subchapter.

(2) Right of action.— If the accrued payments withheld under the terms of the contract are insufficient to reimburse all the laborers and mechanics who have not been paid the wages required under this subchapter, the laborers and mechanics have the same right to bring a civil action and intervene against the contractor and the contractor's sureties as is conferred by law on persons furnishing labor or materials. In those proceedings it is not a

defense that the laborers and mechanics accepted or agreed to accept less than the required rate of wages or voluntarily made refunds.

(b) List of Contractors Violating Contracts.—

(1) In general.— The Comptroller General shall distribute to all departments of the Federal Government a list of the names of persons whom the Comptroller General has found to have disregarded their obligations to employees and subcontractors.

(2) Restriction on awarding contracts.— No contract shall be awarded to persons appearing on the list or to any firm, corporation, partnership, or association in which the persons have an interest until three years have elapsed from the date of publication of the list.

\* \* \* \*

**Sec. 3146. Effect on other federal laws**

This subchapter does not supersede or impair any authority otherwise granted by federal law to provide for the establishment of specific wage rates.

**Sec. 3147. Suspension of this subchapter during a national emergency**

The President may suspend the provisions of this subchapter during a national emergency.

**Sec. 3148. Application of this subchapter to certain contracts**

This subchapter applies to a contract authorized by law that is made without regard to section 3709 of the Revised Statutes (41 U.S.C. 5), or on a cost-plus-a-fixed-fee basis or otherwise without advertising for proposals, if this subchapter otherwise would apply to the contract.

# Contract Work Hours and, Safety Standards Act, as Amended

---



U.S. Department of Labor  
Employment Standards Administration  
Wage and Hour Division

WH Publication 1432  
(Revised April 2009)

Materials contained in this publication is in the public domain and may be reproduced, fully or partially, without permission of the federal Government. Source credit is requested but not required. Permission is required only to reproduce any copyrighted material contained herein.

This material will be made available to Sensory impaired individuals upon request.  
Voice phone: 202-693-0675  
TDD\* phone: 202-523-9530

An Act

To revise, codify, and enact without substantive change certain general and permanent laws, related to public buildings, property, and works, as title 40, United States Code, “Public Buildings, Property, and Works”.

*Be it enacted by the Senate and House of Representatives of the United States of America in Congress assembled,*

**SECTION 1. TITLE 40, UNITED STATES CODE.**

Certain general and permanent laws of the United States, related to public buildings, property, and works, are revised, codified, and enacted as title 40, United States Code, “Public Buildings, Property, and Works”, as follows:

**TITLE 40—PUBLIC BUILDINGS, PROPERTY, AND WORKS**

\* \* \* \*

**SUBTITLE II—PUBLIC BUILDINGS AND WORKS**

**PART A—GENERAL**

\* \* \* \*

**CHAPTER 37 – CONTRACT WORK HOURS AND SAFETY STANDARDS**

\* \* \* \*

**Sec. 3141. Definitions**

(a) Definition.— In this chapter, the term “Federal Government” has the same meaning that the term “United States” had in the Contract Work Hours and Safety Standards Act (Public Law 87-581, 76 Stat. 357).

(b) Application.—

(1) Contracts.— This chapter applies to—

<sup>1</sup>Pub. L. 109-284 Sec. 6(14), (15), (16), and (17) made minor technical corrections in Secs 3701, 3702, and 3704 (Sept. 27, 2006, 120 Stat.1213.)

<sup>2</sup>The Contract Work Hours and Safety Standards Act, referred to in subsec. (a), is title I of Pub. L. 87-581, Aug. 13, 1962, 76 Stat. 357, as amended, which was classified generally to subchapter II (Sec. 327 et seq.) of chapter 5 of former Title 40, Public Buildings, Property, and Works, prior to repeal and reenactment as this chapter by Pub. L. 107-217, Secs. 1, 6 (b), Aug. 21, 2002, 116 Stat. 1062, 1304. Section 101 of title I of Pub. L. 87-581 was classified to section 327 of former Title 40 and was repealed and not reenacted by Pub. L. 107-217.

(A) any contract that may require or involve the employment of laborers or mechanics on a public work of the Federal Government, a territory of the United States,

or the District of Columbia; and

(B) any other contract that may require or involve the employment of laborers or mechanics if the contract is one—

(i) to which the Government, an agency or instrumentality of the Government, a territory, or the District of Columbia is a party;

(ii) which is made for or on behalf of the Government, an agency or instrumentality, a territory, or the District of Columbia; or

(iii) which is a contract for work financed at least in part by loans or grants from, or loans insured or guaranteed by, the Government or an agency or instrumentality under any federal law providing wage standards for the work.

(2) Laborers and mechanics.— This chapter applies to all laborers and mechanics employed by a contractor or subcontractor in the performance of any part of the work under the contract—

(A) including watchmen, guards, and workers performing services in connection with dredging or rock excavation in any river or harbor of the United States, a territory,

or the District of Columbia; but

(B) not including an employee employed as a seaman.

(3) Exceptions.—

(A) This chapter.— This chapter does not apply to—

(i) a contract for—

(I) transportation by land, air, or water;

(II) the transmission of intelligence; or

(III) the purchase of supplies or materials or articles ordinarily available in the open market;

(ii) any work required to be done in accordance with the provisions of the Walsh-Healey Act (41 U.S.C. 35 et seq.); and

(iii) a contract in an amount that is not greater than \$100,000.

(B) Section 3702.— Section 3702 of this title does not apply to work where the assistance described in paragraph (1)(B)(iii) from the Government or an agency or instrumentality is only a loan guarantee or insurance.

### **3702. Work hours.**

(a) Standard Workweek.— The wages of every laborer and mechanic employed by any contractor or subcontractor in the performance of work on a contract described in section 3701 of this title shall be computed on the basis of a standard workweek of 40 hours. Work in excess of the standard workweek is permitted subject to this section. For each workweek in which the laborer or mechanic is so employed, wages include compensation, at a rate not less than one and one-half times the basic rate of pay, for all hours worked in excess of 40 hours in the workweek.



(b) Contract Requirements.— A contract described in section 3701 of this title, and any obligation of the Federal Government, a territory of the United States, or the District of Columbia in connection with that contract, must provide that—

(1) a contractor or subcontractor contracting for any part of the contract work which may require or involve the employment of laborers or mechanics shall not require or permit any laborer or mechanic, in any workweek in which the laborer or mechanic is employed on that work, to work more than 40 hours in that workweek, except as provided in this chapter; and

(2) when a violation of clause (1) occurs, the contractor and any subcontractor responsible for the violation are liable—

(A) to the affected employee for the employee's unpaid wages; and

(B) to the Government, the District of Columbia, or a territory for liquidated damages as provided in the contract.

(c) Liquidated Damages.— Liquidated damages under subsection (b)(2)(B) shall be computed for each individual employed as a laborer or mechanic in violation of this chapter and shall be equal to \$10 for each calendar day on which the individual was required or permitted to work in excess of the standard workweek without payment of the overtime wages required by this chapter.

(d) Amounts Withheld to Satisfy Liabilities.— Subject to section 3703 of this title, the governmental agency for which the contract work is done or which is providing financial assistance for the work may withhold, or have withheld, from money payable because of work performed by a contractor or subcontractor, amounts administratively determined to be necessary to satisfy the liabilities of the contractor or subcontractor for unpaid wages and liquidated damages as provided in this section.

### **3703. Report of violations and withholding of amounts for unpaid wages and liquidated damages.**

(a) Reports of Inspectors.— An officer or individual designated as an inspector of the work to be performed under a contract described in section 3701 of this title, or to aid in the enforcement or fulfillment of the contract, on observation or after investigation immediately shall report to the proper officer of the Federal Government, a territory of the United States, or the District of Columbia all violations of this chapter occurring in the performance of the work, together with the name of each laborer or mechanic who was required or permitted to work in violation of this chapter and the day the violation occurred.

(b) Withholding Amounts.—

(1) Determining amount.— The amount of unpaid wages and liquidated damages owing under this chapter shall be determined administratively.

(2) Amount directed to be withheld.— The officer or individual whose duty it is to approve the payment of money by the Government, territory, or District of Columbia in connection with the performance of the contract work shall direct the amount of—

(A) liquidated damages to be withheld for the use and benefit of the Government, territory, or District; and

(B) unpaid wages to be withheld for the use and benefit of the laborers and mechanics who were not compensated as required under this chapter.

(3) Payment.— The Comptroller General shall pay the amount administratively determined to be due directly to the laborers and mechanics from amounts withheld on account of underpayments of wages if the amount withheld is adequate. If the amount withheld is not adequate, the Comptroller General shall pay an equitable proportion of the amount due.

(c) Right of Action and Intervention Against Contractors and Sureties.— If the accrued payments withheld under the terms of the contract are insufficient to reimburse all the laborers and mechanics who have not been paid the wages required under this chapter, the laborers and mechanics, in the case of a department or agency of the Government, have the same right of action and intervention against the contractor and the contractor's sureties as is conferred by law on persons furnishing labor or materials. In those proceedings it is not a defense that the laborers and mechanics accepted or agreed to accept less than the required rate of wages or voluntarily made refunds.

(d) Review Process.—

(1) Time limit for appeal.— Within 60 days after an amount is withheld as liquidated damages, any contractor or subcontractor aggrieved by the withholding may appeal to the head of the agency of the Government or territory for which the contract work is done or which is providing financial assistance for the work, or to the Mayor of the District of Columbia in the case of liquidated damages withheld for the use and benefit of the District.

(2) Review by agency head or mayor.— The agency head or Mayor may review the administrative determination of liquidated damages. The agency head or Mayor may issue a final order affirming the determination or may recommend to the Secretary of Labor that an appropriate adjustment in liquidated damages be made, or that the contractor or subcontractor be relieved of liability for the liquidated damages, if it is found that the amount is incorrect or that the contractor or subcontractor violated this chapter inadvertently, notwithstanding the exercise of due care by the contractor or subcontractor and the agents of the contractor or subcontractor.

(3) Review by secretary.— The Secretary shall review all pertinent facts in the matter and may conduct any investigation the Secretary considers necessary in order to affirm or reject the recommendation. The decision of the Secretary is final.

(4) Judicial action.— A contractor or subcontractor aggrieved by a final order for the withholding of liquidated damages may file a claim in the United States Court of Federal Claims within 60 days after the final order. A final order of the agency head, Mayor, or Secretary is conclusive with respect to findings of fact if supported by substantial evidence.

(e) Applicability of Other Laws.—

(1) Reorganization plan.— Reorganization Plan Numbered 14 of 1950 (eff. May 24, 1950, 64 Stat. 1267) applies to this chapter.

(2) Section 3145.— Section 3145 of this title applies to contractors and subcontractors referred to in section 3145 who are engaged in the performance of contracts subject to this chapter.

**3704. Health and safety standards in building trades and construction industry.**

(a) Condition of Contracts.—

(1) In general.— Each contract in an amount greater than \$100,000 that is entered into under legislation subject to Reorganization Plan Numbered 14 of 1950 (eff. May 24, 1950, 64 Stat. 1267) and is for construction, alteration, and repair, including painting and decorating, must provide that no contractor or subcontractor contracting for any part of the contract work shall require any laborer or mechanic employed in the performance of the contract to work in surroundings or under working conditions that are unsanitary, hazardous, or dangerous to health or safety, as established under construction safety and health standards the Secretary of Labor prescribes by regulation based on proceedings pursuant to section 553 of title 5, provided that the proceedings include a hearing similar in nature to that authorized by section 553 of title 5.

(2) Consultation.— In formulating standards under this section, the Secretary shall consult with the Advisory Committee created by subsection (d).

(b) Compliance.—

(1) Actions to gain compliance.— The Secretary may make inspections, hold hearings, issue orders, and make decisions based on findings of fact as the Secretary considers necessary to gain compliance with this section and any health and safety standard the Secretary prescribes under subsection (a). For those purposes the Secretary and the United States district courts have the authority and jurisdiction provided by sections 4 and 5 of the Walsh-Healey Act (41 U.S.C. 38, 39).

(2) Remedy when noncompliance found.— When the Secretary, after an opportunity for an adjudicatory hearing by the Secretary, establishes noncompliance under this section of any condition of a contract described in—

(A) section 3701 (b)(1)(B)(i) or (ii) of this title, the governmental agency for which the contract work is done may cancel the contract and make other contracts for the completion of the contract work, charging any additional cost to the original contractor; or

(B) section 3701 (b)(1)(B)(iii) of this title, the governmental agency which is providing the financial guarantee, assistance, or insurance for the contract work may withhold the guarantee, assistance, or insurance attributable to the performance of the contract.

(3) Nonapplicability.— Section 3703 of this title does not apply to the enforcement of this section.

(c) Repeated Violations.—

(1) Transmittal of names of repeat violators to comptroller general.— When the Secretary, after an opportunity for an agency hearing, decides on the record that, by repeated willful or grossly negligent violations of this chapter, a contractor or subcontractor has demonstrated that subsection (b) is not effective to protect the safety and health of the employees of the contractor or subcontractor, the Secretary shall make a finding to that effect and, not sooner than 30 days after giving notice of the finding to all interested persons, shall transmit the name of the contractor or subcontractor to the Comptroller General.

(2) Ban on awarding contracts.— The Comptroller General shall distribute each name transmitted under paragraph (1) to all agencies of the Federal Government. Unless the Secretary otherwise recommends, the contractor, subcontractor, or any person in which the contractor or subcontractor has a substantial interest may not be awarded a contract subject to this section until three years have elapsed from the date the name is transmitted to the Comptroller General. The Secretary shall terminate the ban if, before the end of the three-year period, the Secretary, after affording interested persons due notice and an opportunity for a hearing, is satisfied that a contractor or subcontractor whose name was transmitted to the Comptroller General will comply responsibly with the requirements of this section. The Comptroller General shall inform all Government agencies after being informed of the Secretary's action.

(3) Judicial review.— A person aggrieved by the Secretary's action under this subsection or subsection (b) may file with the appropriate United States court of appeals a petition for review of the Secretary's action within 60 days after receiving notice of the Secretary's action. The clerk of the court immediately shall send a copy of the petition to the Secretary. The Secretary then shall file with the court the record on which the action is based. The findings of fact by the Secretary, if supported by substantial evidence, are final. The court may enter a decree enforcing, modifying, modifying and enforcing, or setting aside any part of, the order of the Secretary or the appropriate Government agency. The judgment of the court may be reviewed by the Supreme Court as provided in section 1254 of title 28.

(d) Advisory Committee on Construction Safety and Health.—

(1) Establishment.— There is an Advisory Committee on Construction Safety and Health in the Department of Labor.

(2) Composition.— The Committee is composed of nine members appointed by the Secretary, without regard to chapter 33 of title 5, as follows:

(A) Three members shall be individuals representative of contractors to whom this section applies.

(B) Three members shall be individuals representative of employees primarily in the building trades and construction industry engaged in carrying out contracts to which this section applies.

(C) Three members shall be public representatives who shall be selected on the basis of their professional and technical competence and experience in the construction health and safety field.

(3) Chairman.— The Secretary shall appoint one member as Chairman.

(4) Duties.— The Committee shall advise the Secretary—

(A) in formulating construction safety and health standards and other regulations; and

(B) on policy matters arising in carrying out this section.

(5) Experts and Consultants.— The Secretary may appoint special advisory and technical experts or consultants as may be necessary to carry out the functions of the Committee.

(6) Compensation and expenses.— Committee members are entitled to receive compensation at rates the Secretary fixes, but not more than \$100 a day, including traveltime, when performing Committee business, and expenses under section 5703 of title 5.

### **3705. Safety programs.**

The Secretary of Labor shall—

- (1) provide for the establishment and supervision of programs for the education and training of employers and employees in the recognition, avoidance, and prevention of unsafe working conditions in employment covered by this chapter; and
- (2) collect reports and data and consult with and advise employers as to the best means of preventing injuries.

### **3706. Limitations, variations, tolerances, and exemptions.**

The Secretary of Labor may provide reasonable limitations to, and may prescribe regulations allowing reasonable variations to, tolerances from, and exemptions from, this chapter that the Secretary may find necessary and proper in the public interest to prevent injustice or undue hardship or to avoid serious impairment of the conduct of Federal Government business.

### **3707. Contractor certification or contract clause in acquisition of commercial items not required.**

In a contract to acquire a commercial item (as defined in section 4 of the Office of Federal Procurement Policy Act (41 U.S.C. 403)), a certification by a contractor or a contract clause may not be required to implement a prohibition or requirement in this chapter.

### **3708. Criminal penalties.**

A contractor or subcontractor having a duty to employ, direct, or control a laborer or mechanic employed in the performance of work contemplated by a contract to which this chapter applies that intentionally violates this chapter shall be fined under title 18, imprisoned for not more than six months, or both.

## Applicability

The Project or Program to which the construction work covered by this contract pertains is being assisted by the United States of America and the following Federal Labor Standards Provisions are included in this Contract pursuant to the provisions applicable to such Federal assistance.

**A. 1. (i) Minimum Wages.** All laborers and mechanics employed or working upon the site of the work, will be paid unconditionally and not less often than once a week, and without subsequent deduction or rebate on any account (except such payroll deductions as are permitted by regulations issued by the Secretary of Labor under the Copeland Act (29 CFR Part 3), the full amount of wages and bona fide fringe benefits (or cash equivalents thereof) due at time of payment computed at rates not less than those contained in the wage determination of the Secretary of Labor which is attached hereto and made a part hereof, regardless of any contractual relationship which may be alleged to exist between the contractor and such laborers and mechanics. Contributions made or costs reasonably anticipated for bona fide fringe benefits under Section I(b)(2) of the Davis-Bacon Act on behalf of laborers or mechanics are considered wages paid to such laborers or mechanics, subject to the provisions of 29 CFR 5.5(a)(1)(iv); also, regular contributions made or costs incurred for more than a weekly period (but not less often than quarterly) under plans, funds, or programs, which cover the particular weekly period, are deemed to be constructively made or incurred during such weekly period.

Such laborers and mechanics shall be paid the appropriate wage rate and fringe benefits on the wage determination for the classification of work actually performed, without regard to skill, except as provided in 29 CFR 5.5(a)(4). Laborers or mechanics performing work in more than one classification may be compensated at the rate specified for each classification for the time actually worked therein: Provided, That the employer's payroll records accurately set forth the time spent in each classification in which work is performed. The wage determination (including any additional classification and wage rates conformed under 29 CFR 5.5(a)(1)(ii) and the Davis-Bacon poster (WH-1321) shall be posted at all times by the contractor and its subcontractors at the site of the work in a prominent and accessible, place where it can be easily seen by the workers.

**(ii) (a)** Any class of laborers or mechanics which is not listed in the wage determination and which is to be employed under the contract shall be classified in conformance with the wage determination. HUD shall approve an additional classification and wage rate and fringe benefits therefor only when the following criteria have been met:

**(1)** The work to be performed by the classification requested is not performed by a classification in the wage determination; and

**(2)** The classification is utilized in the area by the construction industry; and

**(3)** The proposed wage rate, including any bona fide fringe benefits, bears a reasonable relationship to the wage rates contained in the wage determination.

**(b)** If the contractor and the laborers and mechanics to be employed in the classification (if known), or their representatives, and HUD or its designee agree on the classification and wage rate (including the amount designated for fringe benefits where appropriate), a report of the action taken shall be sent by HUD or its designee to the Administrator of the Wage and Hour Division, Employment Standards Administration, U.S. Department of Labor, Washington, D.C. 20210. The Administrator, or an authorized representative, will approve, modify, or disapprove every additional classification action within 30 days of receipt and so advise HUD or its designee or will notify HUD or its designee within the 30-day period that additional time is necessary. (Approved by the Office of Management and Budget under OMB control number 1215-0140.)

**(c)** In the event the contractor, the laborers or mechanics to be employed in the classification or their representatives, and HUD or its designee do not agree on the proposed classification and wage rate (including the amount designated for fringe benefits, where appropriate), HUD or its designee shall refer the questions, including the views of all interested parties and the recommendation of HUD or its designee, to the Administrator for determination. The Administrator, or an authorized representative, will issue a determination within 30 days of receipt and so advise HUD or its designee or will notify HUD or its designee within the 30-day period that additional time is necessary. (Approved by the Office of Management and Budget under OMB Control Number 1215-0140.)

**(d)** The wage rate (including fringe benefits where appropriate) determined pursuant to subparagraphs (1)(ii)(b) or (c) of this paragraph, shall be paid to all workers performing work in the classification under this contract from the first day on which work is performed in the classification.

**(iii)** Whenever the minimum wage rate prescribed in the contract for a class of laborers or mechanics includes a fringe benefit which is not expressed as an hourly rate, the contractor shall either pay the benefit as stated in the wage determination or shall pay another bona fide fringe benefit or an hourly cash equivalent thereof.

**(iv)** If the contractor does not make payments to a trustee or other third person, the contractor may consider as part

of the wages of any laborer or mechanic the amount of any costs reasonably anticipated in providing bona fide fringe benefits under a plan or program, Provided, That the Secretary of Labor has found, upon the written request of the contractor, that the applicable standards of the Davis-Bacon Act have been met. The Secretary of Labor may require the contractor to set aside in a separate account assets for the meeting of obligations under the plan or program. (Approved by the Office of Management and Budget under OMB Control Number 1215-0140.)

**2. Withholding.** HUD or its designee shall upon its own action or upon written request of an authorized representative of the Department of Labor withhold or cause to be withheld from the contractor under this contract or any other Federal contract with the same prime contractor, or any other Federally-assisted contract subject to Davis-Bacon prevailing wage requirements, which is held by the same prime contractor so much of the accrued payments or advances as may be considered necessary to pay laborers and mechanics, including apprentices, trainees and helpers, employed by the contractor or any subcontractor the full amount of wages required by the contract. In the event of failure to pay any laborer or mechanic, including any apprentice, trainee or helper, employed or working on the site of the work, all or part of the wages required by the contract, HUD or its designee may, after written notice to the contractor, sponsor, applicant, or owner, take such action as may be necessary to cause the suspension of any further payment, advance, or guarantee of funds until such violations have ceased. HUD or its designee may, after written notice to the contractor, disburse such amounts withheld for and on account of the contractor or subcontractor to the respective employees to whom they are due. The Comptroller General shall make such disbursements in the case of direct Davis-Bacon Act contracts.

**3. (i) Payrolls and basic records.** Payrolls and basic records relating thereto shall be maintained by the contractor during the course of the work preserved for a period of three years thereafter for all laborers and mechanics working at the site of the work. Such records shall contain the name, address, and social security number of each such worker, his or her correct classification, hourly rates of wages paid (including rates of contributions or costs anticipated for bona fide fringe benefits or cash equivalents thereof of the types described in Section 1(b)(2)(B) of the Davis-bacon Act), daily and weekly number of hours worked, deductions made and actual wages paid. Whenever the Secretary of Labor has found under 29 CFR 5.5 (a)(1)(iv) that the wages of any laborer or mechanic include the amount of any costs reasonably anticipated in providing benefits under a plan or program described in Section 1(b)(2)(B) of the Davis-Bacon Act, the contractor shall maintain records which show that the commitment to provide such benefits is enforceable, that the plan or program is financially responsible, and that the plan or program has been

communicated in writing to the laborers or mechanics affected, and records which show the costs anticipated or the actual cost incurred in providing such benefits. Contractors employing apprentices or trainees under approved programs shall maintain written evidence of the registration of apprenticeship programs and certification of trainee programs, the registration of the apprentices and trainees, and the ratios and wage rates prescribed in the applicable programs. (Approved by the Office of Management and Budget under OMB Control Numbers 1215-0140 and 1215-0017.)

**(ii) (a)** The contractor shall submit weekly for each week in which any contract work is performed a copy of all payrolls to HUD or its designee if the agency is a party to the contract, but if the agency is not such a party, the contractor will submit the payrolls to the applicant sponsor, or owner, as the case may be, for transmission to HUD or its designee. The payrolls submitted shall set out accurately and completely all of the information required to be maintained under 29 CFR 5.5(a)(3)(i) except that full social security numbers and home addresses shall not be included on weekly transmittals. Instead the payrolls shall only need to include an individually identifying number for each employee (e.g., the last four digits of the employee's social security number). The required weekly payroll information may be submitted in any form desired. Optional Form WH-347 is available for this purpose from the Wage and Hour Division Web site at <http://www.dol.gov/esa/whd/forms/wh347instr.htm> or its successor site. The prime contractor is responsible for the submission of copies of payrolls by all subcontractors. Contractors and subcontractors shall maintain the full social security number and current address of each covered worker, and shall provide them upon request to HUD or its designee if the agency is a party to the contract, but if the agency is not such a party, the contractor will submit the payrolls to the applicant sponsor, or owner, as the case may be, for transmission to HUD or its designee, the contractor, or the Wage and Hour Division of the Department of Labor for purposes of an investigation or audit of compliance with prevailing wage requirements. It is not a violation of this subparagraph for a prime contractor to require a subcontractor to provide addresses and social security numbers to the prime contractor for its own records, without weekly submission to HUD or its designee. (Approved by the Office of Management and Budget under OMB Control Number 1215-0149.)

**(b)** Each payroll submitted shall be accompanied by a "Statement of Compliance," signed by the contractor or subcontractor or his or her agent who pays or supervises the payment of the persons employed under the contract and shall certify the following:

**(1)** That the payroll for the payroll period contains the information required to be provided under 29 CFR 5.5 (a)(3)(ii), the appropriate information is being maintained under 29 CFR 5.5(a)(3)(i), and that such information is correct and complete;

(2) That each laborer or mechanic (including each helper, apprentice, and trainee) employed on the contract during the payroll period has been paid the full weekly wages earned, without rebate, either directly or indirectly, and that no deductions have been made either directly or indirectly from the full wages earned, other than permissible deductions as set forth in 29 CFR Part 3;

(3) That each laborer or mechanic has been paid not less than the applicable wage rates and fringe benefits or cash equivalents for the classification of work performed, as specified in the applicable wage determination incorporated into the contract.

(c) The weekly submission of a properly executed certification set forth on the reverse side of Optional Form WH-347 shall satisfy the requirement for submission of the "Statement of Compliance" required by subparagraph A.3.(ii)(b).

(d) The falsification of any of the above certifications may subject the contractor or subcontractor to civil or criminal prosecution under Section 1001 of Title 18 and Section 231 of Title 31 of the United States Code.

(iii) The contractor or subcontractor shall make the records required under subparagraph A.3.(i) available for inspection, copying, or transcription by authorized representatives of HUD or its designee or the Department of Labor, and shall permit such representatives to interview employees during working hours on the job. If the contractor or subcontractor fails to submit the required records or to make them available, HUD or its designee may, after written notice to the contractor, sponsor, applicant or owner, take such action as may be necessary to cause the suspension of any further payment, advance, or guarantee of funds. Furthermore, failure to submit the required records upon request or to make such records available may be grounds for debarment action pursuant to 29 CFR 5.12.

#### 4. Apprentices and Trainees.

(i) **Apprentices.** Apprentices will be permitted to work at less than the predetermined rate for the work they performed when they are employed pursuant to and individually registered in a bona fide apprenticeship program registered with the U.S. Department of Labor, Employment and Training Administration, Office of Apprenticeship Training, Employer and Labor Services, or with a State Apprenticeship Agency recognized by the Office, or if a person is employed in his or her first 90 days of probationary employment as an apprentice in such an apprenticeship program, who is not individually registered in the program, but who has been certified by the Office of Apprenticeship Training, Employer and Labor Services or a State Apprenticeship Agency (where appropriate) to be eligible for probationary employment as an apprentice. The allowable ratio of apprentices to journeymen on the job site in any craft classification shall not be greater than the ratio permitted to the contractor as to the entire work force under the registered program. Any worker listed on a payroll at an apprentice wage rate, who

is not registered or otherwise employed as stated above, shall be paid not less than the applicable wage rate on the wage determination for the classification of work actually performed. In addition, any apprentice performing work on the job site in excess of the ratio permitted under the registered program shall be paid not less than the applicable wage rate on the wage determination for the work actually performed. Where a contractor is performing construction on a project in a locality other than that in which its program is registered, the ratios and wage rates (expressed in percentages of the journeyman's hourly rate) specified in the contractor's or subcontractor's registered program shall be observed. Every apprentice must be paid at not less than the rate specified in the registered program for the apprentice's level of progress, expressed as a percentage of the journeymen hourly rate specified in the applicable wage determination. Apprentices shall be paid fringe benefits in accordance with the provisions of the apprenticeship program. If the apprenticeship program does not specify fringe benefits, apprentices must be paid the full amount of fringe benefits listed on the wage determination for the applicable classification. If the Administrator determines that a different practice prevails for the applicable apprentice classification, fringes shall be paid in accordance with that determination. In the event the Office of Apprenticeship Training, Employer and Labor Services, or a State Apprenticeship Agency recognized by the Office, withdraws approval of an apprenticeship program, the contractor will no longer be permitted to utilize apprentices at less than the applicable predetermined rate for the work performed until an acceptable program is approved.

(ii) **Trainees.** Except as provided in 29 CFR 5.16, trainees will not be permitted to work at less than the predetermined rate for the work performed unless they are employed pursuant to and individually registered in a program which has received prior approval, evidenced by formal certification by the U.S. Department of Labor, Employment and Training Administration. The ratio of trainees to journeymen on the job site shall not be greater than permitted under the plan approved by the Employment and Training Administration. Every trainee must be paid at not less than the rate specified in the approved program for the trainee's level of progress, expressed as a percentage of the journeyman hourly rate specified in the applicable wage determination. Trainees shall be paid fringe benefits in accordance with the provisions of the trainee program. If the trainee program does not mention fringe benefits, trainees shall be paid the full amount of fringe benefits listed on the wage determination unless the Administrator of the Wage and Hour Division determines that there is an apprenticeship program associated with the corresponding journeyman wage rate on the wage determination which provides for less than full fringe benefits for apprentices. Any employee listed on the payroll at a trainee rate who is not registered and participating in a training plan approved by



the Employment and Training Administration shall be paid not less than the applicable wage rate on the wage determination for the work actually performed. In addition, any trainee performing work on the job site in excess of the ratio permitted under the registered program shall be paid not less than the applicable wage rate on the wage determination for the work actually performed. In the event the Employment and Training Administration withdraws approval of a training program, the contractor will no longer be permitted to utilize trainees at less than the applicable predetermined rate for the work performed until an acceptable program is approved.

**(iii) Equal employment opportunity.** The utilization of apprentices, trainees and journeymen under 29 CFR Part 5 shall be in conformity with the equal employment opportunity requirements of Executive Order 11246, as amended, and 29 CFR Part 30.

**5. Compliance with Copeland Act requirements.** The contractor shall comply with the requirements of 29 CFR Part 3 which are incorporated by reference in this contract

**6. Subcontracts.** The contractor or subcontractor will insert in any subcontracts the clauses contained in subparagraphs 1 through 11 in this paragraph A and such other clauses as HUD or its designee may by appropriate instructions require, and a copy of the applicable prevailing wage decision, and also a clause requiring the subcontractors to include these clauses in any lower tier subcontracts. The prime contractor shall be responsible for the compliance by any subcontractor or lower tier subcontractor with all the contract clauses in this paragraph.

**7. Contract termination; debarment.** A breach of the contract clauses in 29 CFR 5.5 may be grounds for termination of the contract and for debarment as a contractor and a subcontractor as provided in 29 CFR 5.12.

**8. Compliance with Davis-Bacon and Related Act Requirements.** All rulings and interpretations of the Davis-Bacon and Related Acts contained in 29 CFR Parts 1, 3, and 5 are herein incorporated by reference in this contract

**9. Disputes concerning labor standards.** Disputes arising out of the labor standards provisions of this contract shall not be subject to the general disputes clause of this contract. Such disputes shall be resolved in accordance with the procedures of the Department of Labor set forth in 29 CFR Parts 5, 6, and 7. Disputes within the meaning of this clause include disputes between the contractor (or any of its subcontractors) and HUD or its designee, the U.S. Department of Labor, or the employees or their representatives.

**10. (i) Certification of Eligibility.** By entering into this contract the contractor certifies that neither it (nor he or she) nor any person or firm who has an interest in the contractor's firm is a person or firm ineligible to be awarded Government contracts by virtue of Section 3(a) of the Davis-Bacon Act or 29 CFR 5.12(a)(1) or to be

awarded HUD contracts or participate in HUD programs pursuant to 24 CFR Part 24.

**(ii)** No part of this contract shall be subcontracted to any person or firm ineligible for award of a Government contract by virtue of Section 3(a) of the Davis-Bacon Act or 29 CFR 5.12(a)(1) or to be awarded HUD contracts or participate in HUD programs pursuant to 24 CFR Part 24.

**(iii)** The penalty for making false statements is prescribed in the U.S. Criminal Code, 18 U.S.C. 1001. Additionally, U.S. Criminal Code, Section 1 01 0, Title 18, U.S.C., "Federal Housing Administration transactions", provides in part: "Whoever, for the purpose of . . . influencing in any way the action of such Administration..... makes, utters or publishes any statement knowing the same to be false..... shall be fined not more than \$5,000 or imprisoned not more than two years, or both."

**11. Complaints, Proceedings, or Testimony by Employees.** No laborer or mechanic to whom the wage, salary, or other labor standards provisions of this Contract are applicable shall be discharged or in any other manner discriminated against by the Contractor or any subcontractor because such employee has filed any complaint or instituted or caused to be instituted any proceeding or has testified or is about to testify in any proceeding under or relating to the labor standards applicable under this Contract to his employer.

**B. Contract Work Hours and Safety Standards Act.** The provisions of this paragraph B are applicable where the amount of the prime contract exceeds \$100,000. As used in this paragraph, the terms "laborers" and "mechanics" include watchmen and guards.

**(1) Overtime requirements.** No contractor or subcontractor contracting for any part of the contract work which may require or involve the employment of laborers or mechanics shall require or permit any such laborer or mechanic in any workweek in which the individual is employed on such work to work in excess of 40 hours in such workweek unless such laborer or mechanic receives compensation at a rate not less than one and one-half times the basic rate of pay for all hours worked in excess of 40 hours in such workweek.

**(2) Violation; liability for unpaid wages; liquidated damages.** In the event of any violation of the clause set forth in subparagraph (1) of this paragraph, the contractor and any subcontractor responsible therefor shall be liable for the unpaid wages. In addition, such contractor and subcontractor shall be liable to the United States (in the case of work done under contract for the District of Columbia or a territory, to such District or to such territory), for liquidated damages. Such liquidated damages shall be computed with respect to each individual laborer or mechanic, including watchmen and guards, employed in violation of the clause set forth in subparagraph (1) of this paragraph, in the sum of \$10 for each calendar day on which such individual was required or permitted to work in excess of the standard workweek of 40 hours without payment of the overtime wages required by the clause set forth in subparagraph (1) of this paragraph.

---

**(3) Withholding for unpaid wages and liquidated damages.** HUD or its designee shall upon its own action or upon written request of an authorized representative of the Department of Labor withhold or cause to be withheld, from any moneys payable on account of work performed by the contractor or subcontractor under any such contract or any other Federal contract with the same prime contract, or any other Federally-assisted contract subject to the Contract Work Hours and Safety Standards Act which is held by the same prime contractor such sums as may be determined to be necessary to satisfy any liabilities of such contractor or subcontractor for unpaid wages and liquidated damages as provided in the clause set forth in subparagraph (2) of this paragraph.

**(4) Subcontracts.** The contractor or subcontractor shall insert in any subcontracts the clauses set forth in subparagraph (1) through (4) of this paragraph and also a clause requiring the subcontractors to include these clauses in any lower tier subcontracts. The prime contractor shall be responsible for compliance by any subcontractor or lower tier subcontractor with the clauses set forth in subparagraphs (1) through (4) of this paragraph.

**C. Health and Safety.** The provisions of this paragraph C are applicable where the amount of the prime contract exceeds \$100,000.

**(1)** No laborer or mechanic shall be required to work in surroundings or under working conditions which are unsanitary, hazardous, or dangerous to his health and safety as determined under construction safety and health standards promulgated by the Secretary of Labor by regulation.

**(2)** The Contractor shall comply with all regulations issued by the Secretary of Labor pursuant to Title 29 Part 1926 and failure to comply may result in imposition of sanctions pursuant to the Contract Work Hours and Safety Standards Act, (Public Law 91-54, 83 Stat 96). 40 USC 3701 et seq.

**(3)** The contractor shall include the provisions of this paragraph in every subcontract so that such provisions will be binding on each subcontractor. The contractor shall take such action with respect to any subcontractor as the Secretary of Housing and Urban Development or the Secretary of Labor shall direct as a means of enforcing such provisions.

**ATTACHMENT TO FEDERAL LABOR STANDARDS PROVISIONS**

**SO-CALLED "ANTI-KICKBACK ACT" AND REGULATIONS PROMULGATED  
PURSUANT THERETO BY THE SECRETARY OF LABOR,  
UNITED STATES DEPARTMENT OF LABOR**

**TITLE 18. U.S.C., Section 874**

(Replaces Section 1 of the Act of June 13, 1934 (48 Stat. 948, 40 U.S.C., sec. 276b) pursuant to the Act of June 25, 1948, 62 Stat. 862)

**KICKBACKS FROM PUBLIC WORKS EMPLOYEES.**

Whoever by force, intimidation, or threat of procuring dismissal from employment, or by any other manner whatsoever induces any person employed in the construction, prosecution, completion or repair of any public building, public work, or building or work financed in whole or in part by loans or grants from the United States, to give up any part of the compensation to which he is entitled under his contract of employment, shall be fined not more than \$5,000 or imprisoned not more than five years, or both.

**SECTION 2 OF THE ACT OF JUNE 13, 1934" AS AMENDED**  
(48 Stat. 948, 62 Stat. 862.63 Stat. 108, 72 Stat. 967, 40 U.S.C., sec. 276c)

The Secretary of Labor shall make reasonable regulations for contractors and subcontractors engaged in the construction, prosecution, completion or repair of public buildings, public works or buildings or works financed in whole or in part by loans or grants from the United States, including a provision that each contractor and subcontractor shall furnish weekly a statement with respect to wages paid each employee during the preceding week.

Section 1001 of Title 18 (United States Code) shall apply to such statements.

XXX

Pursuant to the aforesaid Anti-Kickback Act, the Secretary of Labor, United States Department of Labor, has promulgated the regulations hereinafter set forth, which regulations are found in Title 29, Subtitle A, Code of Federal Regulations, Part 3. The term "this part," as used in the regulations hereinafter set forth, refers to Part 3 last above mentioned. Said regulations are as follows:

**TITLE 29 - LABOR**

**Subtitle A - Office of the Secretary of Labor**

**PART 3 - CONTRACTORS AND SUBCONTRACTORS ON PUBLIC BUILDING OR PUBLIC WORK FINANCED IN WHOLE OR IN PART .BY LOANS OR GRANTS FROM THE UNITED STATES**

**Section 3.1 Purpose and scope.**

This part prescribes "anti-kickback" regulations under section 2 of the Act of June 13, 1934, as amended (40 U.S.C. 276c) popularly known as the Copeland Act. This part applies to any contract which is subject to Federal wage standards and which is for the construction, prosecution, completion, or repair of public buildings, public works or buildings or works financed in whole or in part by loans or grants from the United States. The part is intended to aid in the enforcement of the minimum wage provisions of the Davis-Bacon Act and the various statutes dealing with Federally-assisted construction that contain similar minimum wage provisions, including

those provisions which are not subject to Reorganization Plan No. 14 (e.g., the College Housing Act of 1959), and in the enforcement of the overtime provisions of the Contract Work Hours Standards Act whenever they are applicable to construction work. The part details the obligation of contractors and subcontractors relative to the weekly submission of statements regarding the wages paid on work covered thereby; sets for the circumstances and procedures governing the making of payroll deductions from the wages of those employed on such work; and delineates the methods of payment permissible on such work.

### Section 3.2 Definitions

As used in the regulations in this part:

(a) The terms "building" or "work" generally include construction activity as distinguished from manufacturing, furnishing of materials, or servicing and maintenance work. The terms include, without limitation, buildings, structures, and improvements of all types, such as bridges, dams, plants, highways, parkways, streets, subways, tunnels, sewers, mains, power lines, pumping stations, railways, airports, terminals, docks, piers, wharves, ways, lighthouses, buoys, jetties, breakwaters, levees, and canals; dredging, shoring, scaffolding, drilling, blasting, excavating, clearing, and landscaping, unless conducted in connection with and at the site of such a building or work as is described in the foregoing sentence, the manufacturing or furnishing of materials, articles, supplies, or equipment (whether or not a Federal or State agency acquires title to such materials, articles, supplies, or equipment during the course of the manufacture or furnishing, or owns the materials from which they are manufactured or furnished) is not a "building" or "work" within the meaning of the regulations in this part.

(b) The terms "construction," "prosecution," "completion," or "repair" mean all the types of work done on a particular building or work at the site thereof, including, without limitation, altering, remodeling, painting and decorating, the transportation of materials and supplies to or from the building or work by the employees of the construction contractor or construction subcontractor, and the manufacturing or furnishing of materials, articles, supplies, or equipment on the site of the building or work, by persons employed at the site by the contractor or subcontractor.

(c) The terms "public building" or "public work" include building or work for whose construction, prosecution, completion, or repair, as defined above, a Federal agency is a contracting party, regardless of whether title thereof is in a Federal agency.

(d) The term "Building or work financed in whole or in part by loans or grants from the United States" included building or work for whose construction, prosecution, completion, or repair, as defined above, payment or part payment is made directly or indirectly from funds provided by loans or grants by a Federal agency. The term does not include building or work for which Federal assistance is limited solely to loan guarantees or insurance.

(e) Every person paid by a contractor or subcontractor in any manner for his labor in the construction, prosecution, completion, or repair of a public building or public work or building or work financed in whole or in part by loans or grants from the United States is "employed" and receiving "wages," regardless of any contractual relationship alleged to exist between him and the real employer.

(f) The term "any affiliated person" includes a spouse, child, parent, or other close relative of the contractor or subcontractor, a partner or officer of the contractor or subcontractor closely connected with the contractor subcontractor as parent, subsidiary or otherwise, and an officer or agent of such corporation.

(g) The term "Federal agency" means the United States, the District of Columbia, and all executive departments, independent establishments, administrative agencies, and instrumentalities of the United States and of the District of Columbia, or any of the foregoing departments, establishments, agencies, and instrumentalities.

**Section 3.3 Weekly statement with respect to payment of wages.**

(a) As used in this section, the term "employee" shall not apply to persons in classifications higher than that of laborer or mechanic and those who are the immediate supervisors of such employees.

(b) Each "contractor or subcontractor engaged in the construction, prosecution, completion, or repair of any public building or public work, or building, or work financed in whole or in part by loans or grants from the United States, shall furnish each week a statement with respect to the wages paid each of its employees engaged on work covered by 29 CFR Parts 3 and 5 during the proceeding weekly payroll period. This statement shall be executed by the contractor or subcontractor or by an authorized officer or employee of the contractor or subcontractor who supervises the payment of wages, and shall be on form WH 348. "Statement of Compliance", or on an identical form on the back of WH 347. "Payroll (For Contractors Optional Use)" or on any form with identical wording. Sample copies of WH 347 and WH 348 may be obtained from the Government contracting or sponsoring agency, and copies of these forms may be purchased at the Government Printing Office.

(c) The requirements of this section shall not apply to any contract of \$2,000 or less.

(d) Upon a written finding by the head of a Federal agency, the Secretary of Labor may provide reasonable limitations, variations, tolerances, and exemptions from the requirements of this section subject to such conditions as the Secretary of Labor may specify.

(29 F. R. 95, Jan. 4, 1964, as amended at 33 F. R. 10186, July 17, 1968)

**Section 3.4 Submission of weekly statements and the preservation and inspection of weekly payroll records.**

(a) Each weekly statement required under Sec. 3.3 shall be delivered by the contractor or subcontractor, within seven days after the regular payment date of the payroll period, to a representative of a Federal or State agency in charge at the site of the building or work, or, if there is no representative of a Federal or State agency at the site of the building or work, the statement shall be mailed by the contractor or subcontractor, within such time, to a Federal or State agency contracting for or financing the building or work. After such examination and check as maybe made, such statement, or a copy thereof, shall be kept available, or shall be transmitted together with a report of any violation, in accordance with applicable procedures prescribed by the United States Department of Labor.

**Section 3.5 Payroll deductions permissible without application to or approval of the Secretary of Labor.**

Deductions made under the circumstances or in the situations described in the paragraphs of this section may be made without application to and approval of the Secretary of Labor.

(a) Any deduction made in compliance with the requirements of Federal, State, or local law, such as Federal or State withholding income taxes and Federal social security taxes.

(b) Any deduction of sums previously paid to the employee as a bona fide prepayment of wages when such prepayment is made without discount or interest. A "bone fide prepayment of wages" is considered to have been made only when cash or, its equivalent has been advanced to the person employed in such manner as to give him complete freedom of disposition of the advanced funds.

(c) Any deduction of amounts required by court process to be paid to another, unless the deduction is in favor of the contractor, subcontractor or any affiliated person, or when collusion or collaboration exists.

(d) Any deduction constituting a contribution on behalf of the person employed to funds established by the employer or representatives of employees, or both, for the purpose of providing either from principal or income, or both, medical or hospital care, pensions or annuities on retirement, death, benefits, compensation for injuries, illness, accidents, sickness, or disability, or for insurance to provide any of the foregoing, or unemployment benefits, vacation pay, savings accounts, or similar payments for the benefit of employees, their families or dependents: Provided, however, that the following standards are met: (1) The deduction is not otherwise prohibited by law: (2) it is either:

(i) Voluntarily consented to by the employee in writing and in advance of the period in which the work is to be done and such consent is not a condition either for the obtaining of or for the continuation of employment, or (ii) provided for in a bona fide collective bargaining agreement between the contractor or subcontractor and representatives of its employees; (3) no profit or other benefit is otherwise obtained, directly or indirectly, by the contractor or subcontractor or any affiliated person in the form of commission, dividend, or otherwise: and (4) the deductions shall serve the convenience and interest of the employee.

(e) Any deduction contributing toward the purchase of United States Defense Stamps and Bonds when voluntarily authorized by the employee.

(f) Any deduction requested by the employee to enable him to repay loans to or to purchase shares in credit union statutes.

(g) Any deduction voluntarily authorized by the employee for the making of contributions to governmental or quasi-governmental agencies, such as the American Red Cross.

(h) Any deduction voluntarily authorized by the employee for the making of contributions to Community Chests, United Givers Funds, and similar charitable organizations.

(i) Any deductions to pay regular union initiation fees and membership dues, not including fines or special assessments: Provided, however, that a collective bargaining agreement between the contractor or subcontractor and representatives of its employees provides for such deductions and the deductions are not otherwise prohibited by law.

(j) Any deduction not more than for the "reasonable cost" of board, lodging, or other facilities meeting the requirements of Section 3(m) of the Fair Labor Standards Act of 1938, as amended, and Part 531 of this title. When such a deduction is made the additional records required under Sec. 516.27(a) of this title shall be kept.

### **Section 3.6 Payroll deductions permissible with the approval of the Secretary of Labor.**

Any contractor, subcontractor may apply to the Secretary of Labor for permission to make any deductions not permitted under Sec. 3.5. The Secretary may grant permission whenever he finds that;

(a) The contractor, subcontractor, or any affiliated person does not make a profit or benefit directly or indirectly for the deduction either in the form of a commission, dividend, or otherwise;

(b) The deduction is not otherwise prohibited by law:

(e) The deduction is either (1) voluntarily consented to by the employee in writing and in advance of the period in which the work is to be done and such consent is not a condition either for the obtaining of employment or its continuance, or (2) provided for in a bona fide collective bargaining agreement between the contractor or subcontractor and representatives of its employees; and

(d) The deduction serves the convenience and interest of the employee.

**Section 3.7 Applications for the approval of the Secretary of Labor.**

Any application for the making of payroll deductions under Sec. 3.6 shall comply with the requirements prescribed in the following paragraphs of this section.

- (a) The application shall be in writing and shall be addressed to the Secretary of Labor.
- (b) The application shall identify the contract or contracts under which the work in question is to be performed. Permission will be given for deductions only on specific, identified contracts, except upon the showing of exceptional circumstances.
- (c) The application shall state affirmatively that there is compliance with the standards set forth in the provision of Sec. 3.6. The affirmation shall be accompanied by a full statement of the facts indicating such compliance.
- (d) The application shall include a description of the proposed deduction, the purpose to be served thereby, and the classes of laborers or mechanics from whose wages the proposed deduction would be made.
- (e) The application shall state the name and business of any third person to whom any funds obtained from the proposed deductions are to be transmitted and the affiliation of such person, if any, with the applicant.

**Section 3.8 Action by the Secretary of Labor upon applications.**

The Secretary of Labor shall decide whether or not the requested deduction is permissible under provisions of Sec. 3.6; and shall notify the applicant in writing of his decision.

**Section 3.9 Prohibited payroll deductions.**

Deductions not elsewhere provided for by this part and which are not found to be permissible under Sec.3.6 are prohibited.

**Section 3.10 Methods of payment of wages.**

The payment of wages shall be by cash, negotiable instruments payable on demand, or the additional forms of compensation for which deductions are permissible under this part. No other methods of payment shall be recognized on work subject to the Copeland Act.

**Section 3. 11 Regulations part of contract.**

All contracts made with respect to the constructions prosecution, completion, or repair of any public building or public work, or building or work financed in whole or in part by loans or grants from the United States covered by the regulations in this part shall expressly bind the contractor or subcontractor to comply with such of the regulations in this part as may be applicable. In this regard, are Sec. 5.5 (a) of this subtitle.

**SECTION 3 CLAUSE**  
**24 CFR §135.38**

All section 3 covered contracts shall include the following clause (referred to as the section 3 clause):

A. The work to be performed under this contract is subject to the requirements of section 3 of the Housing and Urban Development Act of 1968, as amended, 12 U.S.C. 1701u (section 3). The purpose of section 3 is to ensure that employment and other economic opportunities generated by HUD assistance or HUD-assisted projects covered by section 3, shall, to the greatest extent feasible, be directed to low- and very low-income persons, particularly persons who are recipients of HUD assistance for housing.

B. The parties to this contract agree to comply with HUD's regulations in 24 CFR part 135, which implement section 3. As evidenced by their execution of this contract, the parties to this contract certify that they are under no contractual or other impediment that would prevent them from complying with the part 135 regulations.

C. The contractor agrees to send to each labor organization or representative of workers with which the contractor has a collective bargaining agreement or other understanding, if any, a notice advising the labor organization or workers' representative of the contractor's commitments under this section 3 clause, and will post copies of the notice in conspicuous places at the work site where both employees and applicants for training and employment positions can see the notice. The notice shall describe the section 3 preference, shall set forth minimum number and job titles subject to hire, availability of apprenticeship and training positions, the qualifications for each; and the name and location of the person(s) taking applications for each of the positions; and the anticipated date the work shall begin.

D. The contractor agrees to include this section 3 clause in every subcontract subject to compliance with regulations in 24 CFR part 135, and agrees to take appropriate action, as provided in an applicable provision of the subcontract or in this section 3 clause, upon a finding that the subcontractor is in violation of the regulations in 24 CFR part 135. The contractor will not subcontract with any subcontractor where the contractor has notice or knowledge that the subcontractor has been found in violation of the regulations in 24 CFR part 135.

E. The contractor will certify that any vacant employment positions, including training positions, that are filled (1) after the contractor is selected but before the contract is executed, and (2) with persons other than those to whom the regulations of 24 CFR part 135 require employment opportunities to be directed, were not filled to circumvent the contractor's obligations under 24 CFR part 135.

F. Noncompliance with HUD's regulations in 24 CFR part 135 may result in sanctions, termination of this contract for default, and debarment or suspension from future HUD assisted contracts.

G. With respect to work performed in connection with section 3 covered Indian housing assistance, section 7(b) of the Indian Self-Determination and Education Assistance Act (25 U.S.C. 450e) also applies to the work to be performed under this contract. Section 7(b) requires that to the greatest extent feasible (i) preference and opportunities for training and employment shall be given to Indians, and (ii) preference in the award of contracts and subcontracts shall be given to Indian organizations and Indian-owned Economic Enterprises. Parties to this contract that are subject to the provisions of section 3 and section 7(b) agree to comply with section 3 to the maximum extent feasible, but not in derogation of compliance with section 7(b).



General Decision Number: CT180002 01/12/2018 CT2

Superseded General Decision Number: CT20170002

State: Connecticut

Construction Type: Highway

County: New London County in Connecticut.

HIGHWAY CONSTRUCTION PROJECTS

Note: Under Executive Order (EO) 13658, an hourly minimum wage of \$10.35 for calendar year 2018 applies to all contracts subject to the Davis-Bacon Act for which the contract is awarded (and any solicitation was issued) on or after January 1, 2015. If this contract is covered by the EO, the contractor must pay all workers in any classification listed on this wage determination at least \$10.35 per hour (or the applicable wage rate listed on this wage determination, if it is higher) for all hours spent performing on the contract in calendar year 2018. The EO minimum wage rate will be adjusted annually. Please note that this EO applies to the above-mentioned types of contracts entered into by the federal government that are subject to the Davis-Bacon Act itself, but it does not apply to contracts subject only to the Davis-Bacon Related Acts, including those set forth at 29 CFR 5.1(a)(2)-(60). Additional information on contractor requirements and worker protections under the EO is available at [www.dol.gov/whd/govcontracts](http://www.dol.gov/whd/govcontracts).

Modification Number	Publication Date
0	01/05/2018
1	01/12/2018

\* BRCT0001-003 01/02/2018

	Rates	Fringes
<b>BRICKLAYER</b>		
BRICKLAYERS, CEMENT MASONS, CEMENT FINISHERS, PLASTERERS, STONE MASONS....	\$ 33.48	31.66

-----  
 CARP0024-002 05/01/2017

	Rates	Fringes
<b>Carpenters:</b>		
CARPENTERS, PILEDRIVERS.....	\$ 32.60	25.34
DIVER TENDERS.....	\$ 32.60	25.34
DIVERS.....	\$ 41.06	25.34
MILLWRIGHTS.....	\$ 33.14	25.74

-----  
 ELEC0035-003 06/01/2017

	Rates	Fringes
<b>Electricians:</b>		

Bozrah, Colchester,  
 Franklin, Griswold,  
 Lebanon, Ledyard, Lisbon,  
 Montville, North  
 Stonington, Norwich,  
 Preston, Salem, Sprague,  
 Stonington and Voluntown....\$ 39.15                      38+25.17

ELEC0090-003 06/01/2017

East Lyme, Groton, New London, Old Lyme, Waterford, plus the part of Ledyard wherein the property of the Submarine Base is located

	Rates	Fringes
ELECTRICIAN.....	\$ 37.50	38+26.31

ENGI0478-002 04/02/2017

	Rates	Fringes
Power equipment operators:		
GROUP 1.....	\$ 39.30	24.05
GROUP 2.....	\$ 38.98	24.05
GROUP 3.....	\$ 38.24	24.05
GROUP 4.....	\$ 37.85	24.05
GROUP 5.....	\$ 37.26	24.05
GROUP 6.....	\$ 36.95	24.05
GROUP 7.....	\$ 36.61	24.05
GROUP 8.....	\$ 36.21	24.05
GROUP 9.....	\$ 35.78	24.05
GROUP 10.....	\$ 33.74	24.05
GROUP 11.....	\$ 33.74	24.05
GROUP 12.....	\$ 33.68	24.05
GROUP 13.....	\$ 35.21	24.05
GROUP 14.....	\$ 33.10	24.05
GROUP 15.....	\$ 32.79	24.05
GROUP 16.....	\$ 31.96	24.05
GROUP 17.....	\$ 31.55	24.05
GROUP 18.....	\$ 30.90	24.05

Hazardous waste premium \$3.00 per hour over classified rate.

- Crane with 150 ft. boom (including jib): \$1.50 extra.
- Crane with 200 ft. boom (including jib): \$2.50 extra.
- Crane with 250 ft. boom (including jib): \$5.00 extra.
- Crane with 300 ft. boom (including jib): \$7.00 extra.
- Crane with 400 ft. boom (including jib); \$10.00 extra.

All Cranes: When crane operator is operating equipment that requires a fully licensed crane operator to operate he receives an extra \$4.00 premium in addition to the hourly wage rate and benefit contributions:

- 1) Crane handling or erecting structural steel or stone, hoisting engineer(2 drums or over)
- 2) Cranes(100 ton rated capacity and over) Bauer Drill/Caisson
- 3) Cranes(under 100 ton rated capacity)

a. PAID HOLIDAYS: New Year's Day, Good Friday, Memorial Day, Independence Day, Labor Day, Thanksgiving Day and Christmas Day, provided the employee works 3 days during the week in which the holiday falls, if scheduled, and if scheduled, the working day before and the working day after the holiday.

#### POWER EQUIPMENT OPERATORS CLASSIFICATIONS

GROUP 1: Crane Handling or Erecting Structural Steel or tone; Hoisting Engineer (2 drums or over); Front End Loader (7 cubic yards or over) Work Boat 26 ft. & over.

GROUP 2: Cranes (100 ton rated capacity and over); Excavator over 2 cubic yards; Piledriver (\$3.00 premium when operator controls hammer); Bauer Drill/Caisson

GROUP 3: Excavator; Cranes (under 100 ton rated capacity), Gradall; Master Mechanic; Hoisting Engineer (all types of equipment where a drum and cable are used to hoist or drag material regardless of motive power of operation), Rubber tire Excavator (Drott-1085 or similar); Grader Operator; Bulldozer Fine Grade (slopes, shaping, laser or GPS, etc.)

GROUP 4: Trenching machines; Lighter Derrick; Concrete Finishing Machine, cmi Machine or Similar; Koehring Loader (Skooper).

GROUP 5: Specialty Railroad Equipment; Asphalt Spreader; Asphalt Reclaiming achine; Line Grinder; Concrete Pumps; Drills with Self Contained Power Units; Boring Machine; Post Hole Digger; Auger; Pounder; Well Digger; Milling Machine (over 24" Mandrell); Side Boom; Combination Hoe and Loader; Directional Driller.

GROUP 6: Front End Loader (3 cu. yds. up to 7 cubic yards); Bulldozer (Rough grade dozer).

GROUP 7: Asphalt Roller; Concrete Saws and Cutters (Ride on Types); Vermeer Concrete Cutter; Stump Grinder; Scraper; Snooper; Skidder; Milling Machine (24" and Under Mandrel).

GROUP 8: Mechanic; Grease Truck Operator; Hydroblaster; Barrier Mover; Power Stone Spreader; Welder; Work Boat Under 26 ft.; Transfer Machine.

GROUP 9: Front End Loader (under 3 cubic yards); Skid Steer Loader (regardless of attachments); (Bobcat or similar); Fork Lift; Power Chipper; Landscape Equipment (including Hydroseeder).

GROUP 10: Vibratory Hammer, Ice Machine, Diesel and Air Hammer, etc.

GROUP 11: Conveyor; Earth Roller; Power Pavement Breaker (Whiphammer); Robot Demolition Equipment.

GROUP 12: Wellpoint Operator.

GROUP 13: Portable Asphalt Plant Operator; Portable Concrete Plant Operator; Portable Crusher Plant Operator.

GROUP 14: Compressor Battery Operator.

GROUP 15: Power Safety Boat; Vacuum Truck; Zim Mixer; Sweeper; (Minimum for any job requiring a CDL License)

GROUP 16: Elevator Operator; Tow Motor Operator (Solid Tire No Rough Terrain).

GROUP 17: Generator Operator; Compressor Operator; Pump Operator; Welding Machine Operator; Heater operator.

GROUP 18: Maintenance Engineer.

-----  
IRON0015-003 06/26/2017

Rates Fringes

Ironworkers: (Reinforcing & Structural).....\$ 35.47 33.39

a. PAID HOLIDAY: Labor Day provided employee has been on the payroll for the 5 consecutive work days prior to Labor Day.

-----  
LABO0056-003 04/02/2017

Rates Fringes

Laborers:

GROUP 1.....\$ 29.25 19.50  
GROUP 2.....\$ 29.50 19.50  
GROUP 3.....\$ 29.75 19.50  
GROUP 4.....\$ 30.25 19.50  
GROUP 5.....\$ 31.00 19.50  
GROUP 6.....\$ 31.25 19.50  
GROUP 7.....\$ 16.00 19.50

LABORERS CLASSIFICATIONS

GROUP 1: Laborers (Unskilled), acetylene burner, concrete specialist

GROUP 2: Chain saw operators, fence and guard rail erectors, pneumatic tool operators and powdermen.

GROUP 3: Pipelayers, Jackhammer/Pavement breaker (handheld), mason tenders/catch basin builders, asphalt rakers, air track operators, block paver and curb setter

GROUP 4: Asbestos/lead removal

GROUP 5: Blasters

GROUP 6: Toxic waste remover

GROUP 7: Traffic control signalman

-----  
 LABO0056-004 04/02/2017

	Rates	Fringes
Laborers: (TUNNEL CONSTRUCTION)		
CLEANING, CONCRETE AND CAULKING TUNNEL:		
Concrete Workers, Form Movers and Strippers.....	\$ 31.28	19.50
Form Erectors.....	\$ 31.60	19.50
ROCK SHAFT, CONCRETE, LINING OF SAME AND TUNNEL IN FREE AIR:		
Brakemen, Trackmen, Tunnel Laborers, Shaft Laborers.....	\$ 31.28	19.50
Laborers Topside, Cage Tenders, Bellman.....	\$ 31.17	19.50
Miners.....	\$ 32.22	19.50
SHIELD DRIVE AND LINER PLATE TUNNELS IN FREE AIR:		
Brakemen and Trackmen.....	\$ 31.28	19.50
Miners, Motormen, Mucking Machine Operators, Nozzlemen, Grout Men, Shaft and Tunnel, Steel and Rodmen, Shield and Erector, Arm Operator, Cable Tenders.....	\$ 32.22	19.50
TUNNELS, CAISSON AND CYLINDER WORK IN COMPRESSED AIR:		
Blaster.....	\$ 38.53	19.50
Brakemen, Trackmen, Groutman, Laborers, Outside Lock Tender, Gauge Tenders.....	\$ 38.34	19.50
Change House Attendants, Powder Watchmen, Top on Iron Bolts.....	\$ 36.41	19.50
Mucking Machine Operator...	\$ 39.11	19.50

a. PAID HOLIDAYS: On tunnel work only: New Year's Day, Memorial Day, Independence Day, Labor Day, Thanksgiving Day and Christmas Day.

No employee shall be eligible for holiday pay when he fails, without cause, to work the regular work day preceding the holiday or the regular work day following the holiday.

-----  
 PAIN0011-002 06/01/2017

	Rates	Fringes
Painters:		

Blast and Spray.....	\$ 35.72	20.45
Brush and Roll.....	\$ 32.72	20.45
Tanks, Towers, Swing.....	\$ 34.72	20.45

-----  
PAIN0011-003 06/01/2017

Rates Fringes

Painters: (BRIDGE  
CONSTRUCTION)

Brush, Roller, Blasting (Sand, Water, etc.) Spray...	\$ 48.55	20.45
---	----------	-------

-----  
TEAM0064-003 04/02/2017

Rates Fringes

Truck drivers:

2 Axle Ready Mix.....	\$ 29.23	22.32
2 Axle.....	\$ 29.13	22.32
3 Axle Ready Mix.....	\$ 29.28	22.32
3 Axle.....	\$ 29.23	22.32
4 Axle Ready Mix.....	\$ 29.38	22.32
4 Axle.....	\$ 29.33	22.32
Heavy Duty Trailer 40 tons and over.....	\$ 29.58	22.32
Heavy Duty Trailer up to 40 tons.....	\$ 29.33	22.32
Specialized (Earth moving equipment other than conventional type on-the- road trucks and semi- trailers, including Euclids).....	\$ 29.38	22.32

Hazardous waste removal work receives additional \$1.25 per hour.

a. PAID HOLIDAYS: New Year's Day, Memorial Day, Independence Day, Labor Day, Thanksgiving Day, Christmas Day and Good Friday, provided the employee has at least 31 calendar days of service and works the last scheduled day before and the first scheduled day after the holiday, unless excused.

-----  
WELDERS - Receive rate prescribed for craft performing operation to which welding is incidental.  
=====

Note: Executive Order (EO) 13706, Establishing Paid Sick Leave for Federal Contractors applies to all contracts subject to the Davis-Bacon Act for which the contract is awarded (and any solicitation was issued) on or after January 1, 2017. If this contract is covered by the EO, the contractor must provide employees with 1 hour of paid sick leave for every 30 hours they work, up to 56 hours of paid sick leave each year. Employees must be permitted to use paid sick leave for their own illness, injury or other health-related needs, including

preventive care; to assist a family member (or person who is like family to the employee) who is ill, injured, or has other health-related needs, including preventive care; or for reasons resulting from, or to assist a family member (or person who is like family to the employee) who is a victim of, domestic violence, sexual assault, or stalking. Additional information on contractor requirements and worker protections under the EO is available at [www.dol.gov/whd/govcontracts](http://www.dol.gov/whd/govcontracts).

Unlisted classifications needed for work not included within the scope of the classifications listed may be added after award only as provided in the labor standards contract clauses (29CFR 5.5 (a) (1) (ii)).

-----

The body of each wage determination lists the classification and wage rates that have been found to be prevailing for the cited type(s) of construction in the area covered by the wage determination. The classifications are listed in alphabetical order of "identifiers" that indicate whether the particular rate is a union rate (current union negotiated rate for local), a survey rate (weighted average rate) or a union average rate (weighted union average rate).

#### Union Rate Identifiers

A four letter classification abbreviation identifier enclosed in dotted lines beginning with characters other than "SU" or "UAVG" denotes that the union classification and rate were prevailing for that classification in the survey. Example: PLUM0198-005 07/01/2014. PLUM is an abbreviation identifier of the union which prevailed in the survey for this classification, which in this example would be Plumbers. 0198 indicates the local union number or district council number where applicable, i.e., Plumbers Local 0198. The next number, 005 in the example, is an internal number used in processing the wage determination. 07/01/2014 is the effective date of the most current negotiated rate, which in this example is July 1, 2014.

Union prevailing wage rates are updated to reflect all rate changes in the collective bargaining agreement (CBA) governing this classification and rate.

#### Survey Rate Identifiers

Classifications listed under the "SU" identifier indicate that no one rate prevailed for this classification in the survey and the published rate is derived by computing a weighted average rate based on all the rates reported in the survey for that classification. As this weighted average rate includes all rates reported in the survey, it may include both union and non-union rates. Example: SULA2012-007 5/13/2014. SU indicates the rates are survey rates based on a weighted average calculation of rates and are not majority rates. LA indicates the State of Louisiana. 2012 is the year of survey on which these classifications and rates are based. The next number, 007

in the example, is an internal number used in producing the wage determination. 5/13/2014 indicates the survey completion date for the classifications and rates under that identifier.

Survey wage rates are not updated and remain in effect until a new survey is conducted.

#### Union Average Rate Identifiers

Classification(s) listed under the UAVG identifier indicate that no single majority rate prevailed for those classifications; however, 100% of the data reported for the classifications was union data. EXAMPLE: UAVG-OH-0010 08/29/2014. UAVG indicates that the rate is a weighted union average rate. OH indicates the state. The next number, 0010 in the example, is an internal number used in producing the wage determination. 08/29/2014 indicates the survey completion date for the classifications and rates under that identifier.

A UAVG rate will be updated once a year, usually in January of each year, to reflect a weighted average of the current negotiated/CBA rate of the union locals from which the rate is based.

---

#### WAGE DETERMINATION APPEALS PROCESS

1.) Has there been an initial decision in the matter? This can be:

- \* an existing published wage determination
- \* a survey underlying a wage determination
- \* a Wage and Hour Division letter setting forth a position on a wage determination matter
- \* a conformance (additional classification and rate) ruling

On survey related matters, initial contact, including requests for summaries of surveys, should be with the Wage and Hour Regional Office for the area in which the survey was conducted because those Regional Offices have responsibility for the Davis-Bacon survey program. If the response from this initial contact is not satisfactory, then the process described in 2.) and 3.) should be followed.

With regard to any other matter not yet ripe for the formal process described here, initial contact should be with the Branch of Construction Wage Determinations. Write to:

Branch of Construction Wage Determinations  
Wage and Hour Division  
U.S. Department of Labor  
200 Constitution Avenue, N.W.  
Washington, DC 20210

2.) If the answer to the question in 1.) is yes, then an interested party (those affected by the action) can request review and reconsideration from the Wage and Hour Administrator



(See 29 CFR Part 1.8 and 29 CFR Part 7). Write to:

Wage and Hour Administrator  
U.S. Department of Labor  
200 Constitution Avenue, N.W.  
Washington, DC 20210

The request should be accompanied by a full statement of the interested party's position and by any information (wage payment data, project description, area practice material, etc.) that the requestor considers relevant to the issue.

3.) If the decision of the Administrator is not favorable, an interested party may appeal directly to the Administrative Review Board (formerly the Wage Appeals Board). Write to:

Administrative Review Board  
U.S. Department of Labor  
200 Constitution Avenue, N.W.  
Washington, DC 20210

4.) All decisions by the Administrative Review Board are final.

=====  
END OF GENERAL DECISION

## **CONTRACT FORMS**



## City of Norwich

100 Broadway  
Norwich, CT 06360

Phone: (860)823-3700

Fax: (860)885-2131

### CONTRACT FOR SERVICES

THIS AGREEMENT made and entered into this \_\_\_ day of \_\_\_\_\_, by and between \_\_\_\_\_ (legal name and address), hereinafter called "**Contractor**" and the City of Norwich, 100 Broadway, Norwich, CT 06360, hereinafter called "**City**."

WHEREAS, the City desires to enter into a contract for services, and the Contractor represents itself as competent and qualified to accomplish the specific requirements of this contract to the satisfaction of the City, therefore this contract is entered into under the following terms and conditions:

1. The Contractor agrees to perform the services described below or in attachments if applicable. (Attachments must be specifically labeled; for example, "Attachment A, consisting of \_\_\_\_\_ pages, attached hereto and made a part hereof," and be initialed by authorized representatives of both parties.) Only those attachments specifically referenced in this Contract for Services shall apply. The terms and conditions as contained in this Contract for Services shall take precedence over any conflicting terms as may be attached hereto.

---

---

---

2. **Term of the Contract:** The start date for this Contract shall be \_\_\_\_\_ and the completion date of this Contract shall be \_\_\_\_\_.

3. **Contract Price:** The City shall pay the Contractor for the performance of the Contract in current funds, for the total quantities of work performed for the price of \$ \_\_\_\_\_.

4. **Contract Documents:** The Contract Documents consist of this Agreement, the Standard Bid and Contract Terms and Conditions, the Instructions to Bidders, the Contractor's bid as accepted by the City, the General and Special Conditions of the Work, the Technical Specifications, the drawings and all Addenda attached hereto.

The Contract Documents are complementary and what is called for by any one shall be as binding as if called for by all. In the event of any conflict or inconsistency between the provisions of this Agreement and the provisions of any of the other Contract Documents, the provisions of the Agreement shall prevail.

Reference to standard specifications, manuals or codes of any technical society, organization or association, or to the laws or regulations of any governmental authority, whether such reference be specific or by implication, shall mean the edition of the standard specification, manual, code or laws or regulations identified in the reference. In the event a particular edition is not identified, the reference shall mean the latest edition in effect at the time of receipt of the bid. However, no provision of any referenced standard specification, manual or code (whether or not specifically incorporated by reference in the Contract Documents) shall change the duties and responsibilities of the City, the Contractor or any of their consultants, agents or employees from those set forth in the Contract Documents.

5. **Obligations And Liability Of The Contractor:** The Contractor shall do all the work and perform and furnish all the labor, services, materials, equipment, plant, machinery, apparatus, appliances, tools, supplies and all other things (except as otherwise expressly provided herein) necessary and as herein specified for the proper performance and completion of the Work in the manner and within the time hereinafter specified, in strict accordance with the Drawings,

Specifications and other Contract Documents, in conformity with the directions and to the satisfaction of the City, and at the prices herein agreed upon therefor.

All parts of the Work and all fixtures, equipment, apparatus and other items indicated on the Drawings and not mentioned in the Specifications, or vice versa, and all work and material usual and necessary to make the Work complete in all its parts, including all incidental work necessary to make it complete and satisfactory and ready for use and operation, whether or not they are indicated on the Drawings or mentioned in the Specifications, shall be furnished and executed the same as if they were called for both by the Drawings and by the Specifications.

The Contractor shall coordinate his operations with those of any other contractors who may be employed on other work of the City, shall avoid interference therewith, and shall cooperate in the arrangements for storage of materials and equipment.

The Contractor shall conduct his work so as to interfere as little as possible with private business and public travel. Wherever and whenever necessary or required, he shall maintain fences, furnish watchmen, maintain lights, and take such other precaution as may be necessary to protect life and property.

The Contractor shall indemnify and save harmless the City and its officers, agents, servants and employees, from and against any and all claims, demands, suits, proceedings, liabilities, judgments, awards, losses, damages, costs and expenses, including attorneys' fees, on account of bodily injury, sickness, disease or death sustained by any person or persons or injury or damage to or destruction of any property, directly or indirectly arising out of, relating to or in connection with the Work, whether or not due to or claimed to be due in whole or in part to the active, passive or concurrent negligence or fault of the Contractor, his officers, agents, servants or employees, any of his subcontractors, the City or any of their respective officers, agents, servants or employees and/or any other person or persons, and whether or not such claims, demands, suits or proceedings are just, unjust, groundless, false or fraudulent; and the Contractor shall and does hereby assume and agrees to pay for the defense of all such claims, demands, suits and proceedings, provided, however, that the Contractor shall not be required to indemnify the City, its officers, agents, servants, or employees, against any such damages occasioned solely by acts or omissions of the owner other than supervisory acts or omissions of the City in the Work.

The Contractor shall have complete responsibility for the Work and the protection thereof, and for preventing injuries to persons and damage to the Work and property and utilities on or about the Work, until final completion and final acceptance thereof. He shall in no way be relieved of his responsibility by any right of the City to give permission or directions relating to any part of the Work, by any such permission or directions given, or by failure of the City to give such permission or directions. The Contractor shall bear all costs, expenses, losses and damages on account of the quantity or character of the Work or the nature of the land (including but not limited to subsurface conditions) in or under or on which the Work is done being different from that indicated or shown in the Contract Documents or from what was estimated or expected, or on account of the weather, elements, or other causes.

The Contractor shall conduct his operations so as not to damage existing structures or work installed either by him or by other contractors. In case of any such damage resulting from his operations, he shall repair and make good as new the damaged portions at his own expense with the consent of the damaged party. In the event that consent is not given, the Contractor shall continue liable for the damage caused.

The Contractor shall be as fully responsible to the City for the acts and omissions of his subcontractors, their officers, agents, servants and employees as he is for his own acts and omissions and those of his own officers, agents, servants and employees.

Should the Contractor sustain any loss, damage or delay through any act or omission of any other contractor or any subcontractor of any such other contractor, the Contractor shall have no claim against the City therefor, other than for an extension of time, but shall have recourse solely to such other contractor or subcontractor.

If any other contractor or any subcontractor of any such other contractor shall suffer or claim to have suffered loss, damage or delay by reason of the acts or omissions of the Contractor or of any of his subcontractors, the Contractor agrees to assume the defense against any such claim and to reimburse such other contractor or subcontractor for such loss or damage.

The Contractor agrees to and does hereby indemnify and save harmless the City from and against any and all claims by such other contractors or subcontractors alleging such loss, damage or delay and from and against any and all claims, demands, suits, proceedings, liabilities, judgments, awards, losses, damages, costs and expenses, including attorneys' fees, arising out of, relating to or resulting from such claims.

The Contractor shall promptly pay all federal, state and local taxes which may be assessed against him in connection with the Work or his operations under this Agreement and/or the other Contract Documents, including, but not limited to, taxes attributable to the purchase of material and equipment, to the performance of services, and the employment of persons in the prosecution of the Work.

**6. Supervision Of Work:** The Contractor shall be solely responsible for supervision of the Work, shall give the work the constant attention necessary to ensure the expeditious and orderly progress thereof, and shall cooperate with the City, its officers, agents or employees in every possible way.

At all times, the Contractor shall have as his agent on the Work a competent superintendent capable of reading and thoroughly understanding the Drawings and Specifications, with full authority to execute the directions of the Engineer without delay and to supply promptly such labor, services, materials, equipment, plant, apparatus, appliances, tools, supplies and other items as may be required. Such superintendent shall not be removed from the Work without the prior written consent of the City. If, in the opinion of the City, the superintendent or any successor proves incompetent, the Contractor shall replace him with another person approved by the City; such approval, however, shall in no way relieve or diminish the Contractor's responsibility for supervision of the Work.

Whenever the Contractor or his agent or superintendent is not present on any part of the Work where it may be necessary to give directions or instructions with respect to such work, such directions or instructions may be given by the City to and shall be received and obeyed by the foreman or any other person in charge of the particular work involved.

**7. Insurance:** The Contractor shall procure and maintain insurance of the types specified below, and to the limits for this insurance specified in the Standard Bid and Contract Terms and Conditions and the City of Norwich Code of Ordinances, Article IV., Section 2-71. All insurance shall be obtained from companies satisfactory to the City.

Insurance shall be in such forms as will protect the Contractor from all claims and liability for damages for bodily and personal injury, including accidental death, and for property damage, which may arise from operations under the Contract, whether such operations be by himself, his subcontractors, or by anyone directly or indirectly employed or engaged by him.

The following types of insurance shall be provided before starting and until final completion and acceptance of the Work and expiration of the guarantee period provided for in the Agreement.

- a. Workmen's Compensation and Employer's Liability Insurance.
- b. Bodily Injury Insurance for operations and completed operations and Contractor's Protective Bodily Injury Insurance.
- c. Property Damage Insurance for operations and completed operations and Contractor's Protective Property Damage Insurance, each including coverage for injury to or destruction of wires or pipes and similar property and appurtenant apparatus and the collapse of or structural injury to any building or structure except those on which work under the Contract is being done. Blasting and explosion coverage shall be obtained if there is a need for blasting under the Contract, and no blasting shall be performed until such insurance has been secured.
- d. Bodily Injury Insurance covering the operation of all motor vehicles owned by the Contractor.
- e. Personal Injury Insurance to cover claims for personal injury and including claims brought by employees.
- f. Property Damage Insurance covering the operation of all motor vehicles owned by the Contractor.

- g. Insurance to cover bodily injuries and property damage resulting from the use of motor vehicles not owned by the Contractor, while such vehicles are being operated in connection with the prosecution of the Work.
- h. Contractual Liability Insurance covering the liability assumed by the Contractor under the fifth paragraph of that subsection titled "Obligations and Liability of Contractor" of this Agreement.
- i. Owner's Protective Liability and Property Damage Insurance to protect the City and any Engineer against claims for Property damage and for bodily injuries, including accidental death, caused by the operations of the Contractor or his subcontractors on the Work. The policy shall indicate the City and any Engineer as the named insured. A copy of the policy shall be furnished to the City and a Certificate of Insurance shall be furnished to any Engineer.

All policies shall be so written that the owner will be notified in writing of cancellation or restrictive amendment at least 30 days prior to the effective date of such cancellation or amendment.

Certificates from the Contractor's insurance carriers stating the coverages provided, the limits of liability, and expiration dates shall be filed in triplicate with the Engineer before operations are begun. Such certificates shall be on the form furnished by the Engineer.

Renewal certificates must be furnished by the Contractor prior to the expiration date of any of the initial insurances.

No insurance required or furnished hereunder shall in any way relieve the Contractor of or diminish any of his responsibilities, obligations and liabilities under the Contract.

**8. Contract:** This Agreement, which includes all the Contract Document elements listed in paragraph 1 above, forms the Contract between the parties identified in the heading of this document. In the event that any provision of the Contract conflicts with any other provision of this Contract, the decision of the City will be final.

**9. Funding and Fiscal Year Appropriations:** Appropriations for expenditures by the City and authorization to spend for a particular purpose are ordinarily made on a fiscal year basis. The fiscal year of the City is the twelve (12) month period ending June 30 of each year. The obligations of the City under this Contract for the present or any subsequent fiscal year following the fiscal year in which this Contract is executed are subject to the appropriation of funds sufficient to discharge the City's obligation, which accrues in this or any subsequent fiscal year. In the absence of such appropriation or authorization, this Contract shall be terminated immediately upon the Contractor's receipt of notice to said effect without liability for damages, penalties or other charges arising from early termination. Expenditures for Contracted services that will extend beyond a single fiscal year shall not exceed in any fiscal year the amount appropriated and authorized for said fiscal year. The Contractor's yearly costs, as contained herein, may not exceed the amount appropriated for said year.

**10. Termination:** The Contract may be terminated without cause by either party by giving written notice to the other at least thirty (30) calendar days prior to the effective date of termination stated in the notice. If Contractor fails to fulfill his obligations, the City may terminate this Contract by giving written notice to the Contractor at least seven (7) calendar days before the effective date of termination stated in the notice. The notice shall state the circumstances of the alleged breach and may state a period during which the alleged breach may be cured, which cure shall be subject to approval by the City.

**11. Obligations in Event of Termination:**

A. Upon termination, all finished or unfinished documents, data, studies, and reports prepared by the Contractor pursuant to this Contract, shall become the property of the City.

B. The City shall promptly pay the Contractor for all services performed to the effective date of termination, subject to indemnification provisions of Paragraph 5 hereof and subject to offset of sums due the Contractor against sums owed by the Contractor to the City.

**12. Record keeping, Audit, and Inspection of Records:** The Contractor shall maintain books, records and other compilations of data pertaining to the requirements of the Contract to the extent and in such detail as shall properly substantiate claims for payment under the Contract. All such records shall be kept for a period of six (6) years or for such longer period as is specified herein. All retention periods start on the first day after final payment under this Contract. If any litigation, claim, negotiation, audit or other action involving the records is commenced prior to the expiration of the applicable retention period, all records shall be retained until completion of the action and resolution of all issues resulting therefrom, or until the end of the applicable retention period, whichever is later. The Federal grantor agency, the State Auditor, the City, or any of their duly authorized representatives or designees shall have the right at reasonable times and upon reasonable notice, to examine and copy, at reasonable expense, the books, records, and other compilations of data of the Contractor which pertain to the provisions and requirements of this Contract. Such access shall include on-site audits, review, and copying of records.

**13. Publicity, Publication, Reproduction and Use of Contract Products or Materials:** Unless provided otherwise by law or the City, title and possession of all data, reports, programs, software, equipment, furnishings, and any other documentation or product paid for with City funds shall vest with the City at the termination of the Contract. The Contractor shall at all times obtain the prior written approval of the City before it, any of its officers, agents, employees or subcontractors, either during or after termination of the Contract, makes any statement bearing on the work performed or data collected under this Contract to the press or issues any material for publication through any medium of communication. If the Contractor, or any of its subcontractors, publishes a work dealing with any aspect of performance under the Contract, or of the results and accomplishments attained in such performance, the City shall have a royalty-free non-exclusive and irrevocable license to reproduce, publish or otherwise use and to authorize others to use the publication. The Contractor shall use reasonable means to inform the public that the City provides financial support for its operations and services by explicitly stating on publicity material, stationery, posters and other written materials, and on its premises the following: "This program is supported in part (in full) by the City of Norwich."

**14. Assignment by Contractor and Subcontracting:** The Contractor shall not assign or in any way transfer any interest in this Contract without the prior written consent of the City, nor shall he subcontract any services without the prior written approval of the City.

**15. Connecticut Law:** It is agreed that this contract shall be governed by, construed, and enforced in accordance with the internal laws of the State of Connecticut.

**16. Venue:** In the event of litigation, the parties do agree to be contractually bound to submit themselves to the personal jurisdiction of the state courts of Connecticut. The venue for any court proceeding shall be in the Superior Court for the Judicial District for Norwich at Norwich, Connecticut.

**17. Waiver of Jury Trial:** CONTRACTOR HEREBY EXPRESSLY WAIVES ANY AND ALL RIGHTS IT MAY HAVE TO TRIAL BY JURY OF ANY CLAIM, DEMAND, ACTION OR CAUSE OF ACTION (1) ARISING UNDER THIS AGREEMENT OR ANY OTHER INSTRUMENT, DOCUMENT OR AGREEMENT EXECUTED OR DELIVERED IN CONNECTION HERewith, OR (2) IN ANY WAY CONNECTED WITH OR RELATED OR INCIDENTAL TO THE DEALINGS OF THE PARTIES HERETO OR ANY OF THEM WITH RESPECT TO THIS AGREEMENT OR ANY OTHER INSTRUMENT, DOCUMENT OR AGREEMENT EXECUTED OR DELIVERED IN CONNECTION HERewith, OR THE TRANSACTIONS RELATED HERETO OR THERETO, IN EACH CASE WHETHER NOW EXISTING OR HEREAFTER ARISING, AND WHETHER SOUNDING IN CONTRACT OR TORT OR OTHERWISE; AND CONTRACTOR HEREBY AGREES AND CONSENTS THAT ANY SUCH CLAIM, DEMAND, ACTION OR CAUSE OF ACTION SHALL BE DECIDED BY COURT TRIAL WITHOUT A JURY, AND THE CITY MAY FILE AN ORIGINAL COUNTERPART OR A COPY OF THIS SECTION WITH ANY COURT AS WRITTEN EVIDENCE OF CONTRACTOR'S CONSENT TO THE WAIVER OF ITS RIGHT TO TRIAL BY JURY.

**18. Nondiscrimination and affirmative action provisions, nondiscrimination provisions regarding sexual orientation, Executive Order Number Three and guidelines and rules, Executive Order Number Seventeen, Executive Order Number Sixteen and sexual harassment policy:**

For the purposes of this article, the word "contractor" is substituted for and has the same meaning and effect as if it read "Contractor's name." Section A of this article is inserted in connection with subsection (a) of Section 4a-60 of the General

Statutes of Connecticut, as revised. Section B of this article is inserted in connection with subsection (a) of Section 4a-60a of the General Statutes of Connecticut, as revised.

A. (a) For the purposes of this section, “minority business enterprise” means any small contractor or supplier of materials fifty-one percent or more of the capital stock, if any, or assets of which is owned by a person or persons: (1) who are active in the daily affairs of the enterprise, (2) who have the power to direct the management and policies of the enterprise, and (3) who are members of a minority, as such term is defined in subsection (a) of Conn. Gen. Stat. Section 32-9n; and “good faith” means that degree of diligence which a reasonable person would exercise in the performance of legal duties and obligations. “Good faith efforts” shall include, but not be limited to, those reasonable initial efforts necessary to comply with statutory or regulatory requirements and additional or substituted efforts when it is determined that such initial efforts will not be sufficient to comply with such requirements.

For the purposes of this section, “Commission” means the Commission on Human Rights and Opportunities.

For the purposes of this section, “public works contract” means any agreement between any individual, firm, or corporation and the State or any political subdivision of the State other than a municipality for construction, rehabilitation, conversion, extension, demolition or repair of a public building, highway or other changes or improvements in real property, or which is financed in whole or in part by the State, including, but not limited to, matching expenditures, grants, loans, insurance, or guarantees.

(b) (1) The contractor agrees and warrants that in the performance of the contract such contractor will not discriminate or permit discrimination against any person or group of persons on the grounds of race, color, religious creed, age, marital status, national origin, ancestry, sex, mental retardation, or physical disability, including, but not limited to, blindness, unless it is shown by such contractor that such disability prevents performance of the work involved, in any manner prohibited by the laws of the United States or of the State of Connecticut. The contractor further agrees to take affirmative action to insure that applicants with job-related qualifications are employed and that employees are treated when employed without regard to their race, color, religious creed, age, marital status, national origin, ancestry, sex, mental retardation, or physical disability, including, but not limited to, blindness, unless it is shown by such contractor that such disability prevents performance of the work involved; (2) the contractor agrees, in all solicitations or advertisements for employees placed by or on behalf of the contractor, to state that it is an “affirmative action-equal opportunity employer” in accordance with regulations adopted by the Commission; (3) the contractor agrees to provide each labor union or representative of workers with which such contractor has a collective bargaining agreement or other contract or understanding and each vendor with which such contractor has a contract or understanding, a notice to be provided by the Commission advising the labor union or workers’ representative of the contractor’s commitments under this section, and to post copies of the notice in conspicuous places available to employees and applicants for employment; (4) the contractor agrees to comply with each provision of this section and Conn. Gen. Stat. Sections 46a-68e and 46a-68f and with each regulation or relevant order issued by said commission pursuant to Conn. Gen. Stat. Sections 46a-56, 46a-68e, and 46a-68f; (5) the contractor agrees to provide the Commission on Human Rights and Opportunities with such information requested by the Commission, and permit access to pertinent books, records, and accounts concerning the employment practices and procedures of the contractor as they relate to the provisions of this section and Conn. Gen. Stat. Section 46a-56. If the contract is a public works contract, the contractor agrees and warrants that he will make good faith efforts to employ minority business enterprises as subcontractors and suppliers of materials on such public works project.

(c) Determination of the contractor’s good faith efforts shall include, but shall not be limited to, the following factors: The contractor’s employment and subcontracting policies, patterns and practices; affirmative advertising, recruitment and training; technical assistance activities and such other reasonable activities or efforts as the Commission may prescribe that are designed to ensure the participation of minority business enterprises in public works projects.

(d) The contractor shall develop and maintain adequate documentation, in a manner prescribed by the Commission, of its good faith efforts.

(e) The contractor shall include the provisions of subsection (b) of this section in every subcontract or purchase order entered into in order to fulfill any obligation of a contract with the State and such provisions shall be binding on a subcontractor, vendor, or manufacturer unless exempted by regulations or orders of the Commission. The contractor shall take such action with respect to any such subcontract or purchase order as the Commission may direct as a means of enforcing such provisions including sanctions for noncompliance in accordance with Conn. Gen. Stat. Section 46a-56; provided, if such contractor becomes involved in, or is threatened with, litigation with a subcontractor or vendor as a result of such direction by the Commission, the contractor may request the State of Connecticut to enter into any such litigation or negotiation prior thereto to protect the interests of the State and the State may so enter.



(f) The contractor agrees to comply with the regulations referred to in this section as they exist on the date of this contract and as they may be adopted or amended from time to time during the term of this contract and any amendments thereto.

B. (a) (1) The contractor agrees and warrants that in the performance of the contract such contractor will not discriminate or permit discrimination against any person or group of persons on the grounds of sexual orientation, in any manner prohibited by the laws of the United States or of the State of Connecticut, and that employees are treated when employed without regard to their sexual orientation; (2) the contractor agrees to provide each labor union or representative of workers with which such contractor has a collective bargaining agreement or other contract or understanding and each vendor with which such contractor has a contract or understanding, a notice to be provided by the Commission on Human Rights and Opportunities advising the labor union or workers' representative of the contractor's commitments under this section, and to post copies of the notice in conspicuous places available to employees and applicants for employment; (3) the contractor agrees to comply with each provision of this section and with each regulation or relevant order issued by said commission pursuant to Section 46a-56 of the Connecticut General Statutes; (4) the contractor agrees to provide the Commission on Human Rights and Opportunities with such information requested by the Commission, and permit access to pertinent books, records, and accounts concerning the employment practices and procedures of the contractor that relate to the provisions of this section and Section 46a-56 of the Connecticut General Statutes.

(b) The contractor shall include the provisions of subsection (a) of this section in every subcontract or purchase order entered into in order to fulfill any obligation of a contract with the State and such provisions shall be binding on a subcontractor, vendor, or manufacturer unless exempted by regulations or orders of the Commission. The contractor shall take such action with respect to any such subcontract or purchase order as the Commission may direct as a means of enforcing such provisions including sanctions for noncompliance in accordance with Section 46a-56 of the Connecticut General Statutes; provided, if such contractor becomes involved in, or is threatened with, litigation with a subcontractor or vendor as a result of such direction by the Commission, the contractor may request the State of Connecticut to enter into any such litigation or negotiation prior thereto to protect the interests of the State and the State may so enter.

(c) The contractor agrees to comply with the regulations referred to in this section as they exist on the date of this contract and as they may be adopted or amended from time to time during the term of this contract and any amendments thereto.

C. This contract is subject to the provisions of Executive Order No. Three of Governor Thomas J. Meskill promulgated June 16, 1971, and, as such, this contract may be cancelled, terminated, or suspended by the State Labor Commissioner for violation of or noncompliance with said Executive Order No. Three, or any State or federal law concerning nondiscrimination, notwithstanding that the State Labor Commissioner is not a party to this contract. The parties to this contract, as part of the consideration hereof, agree that said Executive Order No. Three is incorporated herein by reference and made a part hereof. The parties agree to abide by said Executive Order and agree that the State Labor Commissioner shall have continuing jurisdiction in respect to contract performance in regard to nondiscrimination, until the contract is completed or terminated prior to completion.

The contractor agrees, as part consideration hereof, that this contract is subject to the Guidelines and Rules issued by the State Labor Commissioner to implement Executive Order No. Three, and that he will not discriminate in his employment practices or policies, will file all reports as required, and will fully cooperate with the State of Connecticut and the State Labor Commissioner.

D. This contract is subject to the provisions of Executive Order No. Seventeen of Governor Thomas J. Meskill promulgated February 15, 1973, and, as such, this contract may be cancelled, terminated, or suspended by the contracting agency or the State Labor Commissioner for violation of or noncompliance with said Executive Order No. Seventeen, notwithstanding that the State Labor Commissioner may not be a party to this contract. The parties to this contract, as part of the consideration hereof, agree that Executive Order No. Seventeen is incorporated herein by reference and made a part hereof. The parties agree to abide by said Executive Order and agree that the contracting agency and the State Labor Commissioner shall have joint and several continuing jurisdiction in respect to contract performance in regard to listing all employment openings with the Connecticut State Employment Service.

E. This contract is subject to the provisions of Executive Order No. Sixteen of Governor John G. Rowland promulgated August 4, 1999, and, as such, the contract may be canceled, terminated, or suspended by the State for violation of or noncompliance with said Executive Order No. Sixteen. Executive Order No. Sixteen is attached hereto and made a part hereof. The parties agree to comply with such executive order. In addition, the contractor agrees to include a copy of Executive Order No. Sixteen, and the requirement to comply with said executive order, in all contracts with its contractors, subcontractors, consultants, sub-consultants, and vendors.

F. This contract is subject to the provisions of the City of Norwich Sexual Harassment Policy ("Policy") and, as such, the contract may be canceled, terminated, or suspended by the City in the event that the contractor, its employees, contractors, subcontractors, consultants, sub-consultants, or vendors engages in behavior prohibited by the provisions of the Policy (a copy of the Policy is attached hereto). The contractor agrees to include a copy of the Policy, and the requirement to prevent behavior as defined in such Policy, in all contracts with its contractors, subcontractors, consultants, sub-consultants, and vendors.

**19. Force Majeure:** Neither party shall be liable to the other or be deemed to be in breach of this Contract for any failure or delay in rendering performance arising out of causes beyond its reasonable control and without its fault or negligence. Such causes may include, but are not limited to, acts of God or of a public enemy, fires, floods, epidemics, quarantine restrictions, strikes, freight embargoes, or unusually severe weather. Dates or times of performance shall be extended to the extent of delays excused by this section, provided that the party whose performance is affected notifies the other promptly of the existence and nature of such delay.

**20. Compliance with Laws and Indemnification of the City of Norwich:** The Contractor shall comply with all applicable laws, rules, regulations, ordinances, orders or requirements of the State of Connecticut and any governmental authority relating to the delivery of the services specified in this Contract. The City may require the Contractor to pay fines, penalties, and damages that may arise out of or may be imposed because of, the Contractor's breach or failure to comply with the provisions of this Contract. Unless otherwise provided by law the Contractor shall indemnify and hold harmless the City, its agents, officers and employees against any and all liability, loss, damages, penalties, costs or expenses for personal injury or damage to real or tangible personal property which the City may sustain, incur or be required to pay resulting from, arising out of, or in connection with the services performed or delivered under this Contract by reason of acts, inactions, omissions, negligence, reckless or intentional misconduct of the Contractor, its agent(s), officers, employees or subcontractors; provided that the Contractor is notified of any claim within a reasonable time after the City becomes aware of it, and the Contractor is afforded an opportunity to participate in the defense of such claim. In such event, no negotiated settlement agreement shall be binding on the Contractor without the Contractor's concurrence.

**21. Waivers And Severability:** All conditions, covenants, duties and obligations contained in this Contract can be waived only by written agreement. Forbearance or indulgence in any form or manner by a party shall not be construed as a waiver, nor in any way limit the legal or equitable remedies available to that party. A waiver or breach of any term, condition, or covenant by a party shall not constitute a waiver or breach of any other term, condition or covenant. If any court of competent jurisdiction declares a provision of this Agreement invalid, illegal, or otherwise unenforceable, the remaining provisions of the Agreement shall remain in full force and effect.

**22. Amendments:** No amendment to this Contract shall be effective unless it is signed by authorized representatives of both parties and complies with all other regulations and requirements of law.

**23. Entire Agreement:** The parties understand and agree that this Contract and attachments (if any), which includes all Contract Documents, supersede all other verbal and written agreements and negotiations by the parties relating to the services under this Contract.

**24. Notice:** Unless otherwise specified in an attachment hereto, any notice hereunder shall be in writing addressed to the persons and addresses indicated in the caption of this Contract on page 1.

IN WITNESS WHEREOF, the parties hereto have caused this AGREEMENT to be executed in two (2) original copies on the day and year first above written.

OWNER:

CONTRACTOR:

\_\_\_\_\_

\_\_\_\_\_

Its Duly Authorized Agent

Its Duly Authorized Agent

Approved as to form and legality:

\_\_\_\_\_  
Michael E. Driscoll, Corporation Counsel

Date Signed \_\_\_\_\_

LABOR AND MATERIAL PAYMENT BOND

KNOW ALL MEN BY THESE PRESENTS:

That \_\_\_\_\_, as Principal  
(hereinafter called Principal) and \_\_\_\_\_  
as Surety, (hereinafter called Surety) are held and firmly bound unto \_\_\_\_\_  
\_\_\_\_\_ as Obligee (hereinafter called Owner), for the use and  
benefit of claimants as hereinbelow defined;  
in the amount of \_\_\_\_\_ Dollars (\$  
\_\_\_\_\_) for the payment whereof the Principal and Surety bind themselves, their heirs, executors,  
administrators, successors and assigns, jointly and severally, firmly by these presents.

WHEREAS, Principal has by written agreement dated \_\_\_\_\_ entered into a Contract with the  
owner for \_\_\_\_\_

\_\_\_\_\_ which Contract is by reference made a part hereof, and is hereinafter referred to as the Contract.

NOW, THEREFORE, the condition of this obligation is such that, if the said Principal shall promptly pay for all materials furnished and labor supplied or performed in the prosecution of the work included in and under the aforesaid Contract, whether or not the material or labor enters into and becomes a component part of the real asset, then this obligation shall be null and void otherwise it shall remain in full force and effect.

PROVIDED, that any alterations which may be made in the terms of the Contract or in the work to be done under it, or the giving by the Owner or any other forbearance on the part of either the Owner or the Principal to the other shall not in any way release the Principal and the Surety or either or any of them, their heirs, executors, administrators, successors or assigns from their liability hereunder, notice to the Surety for any such alterations, extension or forbearance being hereby waived.

Any party, whether a subcontractor or otherwise, who furnished materials or supplies or performs labor or services in the prosecution of the work under said Contract, and who is not paid therefore, may bring a suit on this Bond in the name of the person suing, prosecute the same to a final judgment and have the execution thereon for such sum as may be justly due.

IN WITNESS WHEREOF, the above-bounded parties have executed this instrument under their several seals this \_\_\_\_\_ day of \_\_\_\_\_, 20\_\_\_\_, the name and corporate seal of each corporate party being hereto affixed and these presents signed by its undersigned representative, pursuant to authority of its governing body.

\_\_\_\_\_  
(Corporate Principal)

Attest:

\_\_\_\_\_

(Business Address)

\_\_\_\_\_ By

\_\_\_\_\_  
Affix  
Corporate  
Seal

\_\_\_\_\_  
(Corporate Surety)

Attest:

\_\_\_\_\_

(Business Address)

\_\_\_\_\_ By

\_\_\_\_\_  
Affix  
Corporate  
Seal

Countersigned  
by \_\_\_\_\_

Attorney-in-Fact, State of \_\_\_\_\_, Power-of- Attorney for person signing for  
Surety Company must be attached to Bond.

PERFORMANCE BOND

KNOW ALL MEN BY THESE PRESENTS:

That \_\_\_\_\_ as Principal, hereinafter called Contractor, and \_\_\_\_\_ as Surety, hereinafter called Surety, are held and firmly bound unto \_\_\_\_\_ as Obligee, hereinafter called Owner, in the amount of \_\_\_\_\_ Dollars (\$ \_\_\_\_\_), for payment whereof Principal and Surety bind themselves, their heirs, executors, administrators, successors and assigns, jointly and severally, firmly by these presents.

WHEREAS, Contract has by written agreement dated \_\_\_\_\_ entered into a Contract with Owner for \_\_\_\_\_

---

which Contract is by reference made a part hereof, and is hereinafter referred to as the Contract.

NOW, THEREFORE, the condition of this obligation is such that, if Contractor shall promptly and faithfully perform said Contract, including such remedial work as may be required under the guaranty during the period of guaranty and shall certify in writing that all wages paid under said Contract to any mechanic, laborer or workman were equal to the rates or wages customary or then prevailing for the same trade or occupation in Connecticut, then this obligation shall be null and void, otherwise it shall remain in full force and effect.

The Surety hereby waives notice of any alteration or extension of time made by the Owner.

Whenever Contractor shall be, and declared by Owner to be in default under the Contract, the Owner having performed Owner's obligations thereunder, the Surety may promptly remedy the default or shall promptly:

- (1) Complete the Contract in accordance with its terms and conditions, by another Contractor acceptable to the Owner, said other Contractor to act as an agent for the Surety, or
- (2) Obtain a Bid or Bids for submission to the Owner for completing the Contract in accordance with its terms and conditions, and upon determination by the Owner and Surety of the lowest responsible Bidder, arrange for a Contract as work progresses (even though there should be a default or a succession of defaults under the Contract or Contracts of completion arranged under this paragraph) sufficient funds to pay the cost of completion less the balance of the contract price, but not exceeding, including, other costs and damages for which the Surety may be liable hereunder, the amount set forth in the first paragraph hereof. The terms "balance of the contract price", as used in this paragraph, shall mean the total amount payable by the Owner to the Contractor under the Contract and any amendments thereto, less the amount properly paid by the Owner to the Contractor.

Unless otherwise required by law, any suit under this Bond must be instituted before the expiration of one (1) year from the date on which the guaranty period under the Contract expires.

No right of action shall accrue on this Bond to or for the use of any person or corporation other than the Owner named herein or the heirs, executors, administrators and successors of the Owner.

IN WITNESS WHEREOF, the above-bounded parties have executed this instrument under their several seals this \_\_\_\_\_ day of \_\_\_\_\_, 20\_\_\_\_, the name and corporate seal of each corporate party being hereto affixed and these presents signed by its undersigned representative, pursuant to authority of its governing body.

No extension of time or other modification of this Bid Bond shall be valid unless agreed in writing by the parties to this Bond.

\_\_\_\_\_  
(Corporate Principal)

Attest:

\_\_\_\_\_  
(Business Address)

\_\_\_\_\_

By

\_\_\_\_\_  
Affix  
Corporate  
Seal

\_\_\_\_\_  
(Corporate Surety)

Attest:

\_\_\_\_\_  
(Business Address)

\_\_\_\_\_

By

\_\_\_\_\_  
Affix  
Corporate  
Seal

Countersigned  
by \_\_\_\_\_

Attorney-in-Fact, State of \_\_\_\_\_, Power-of- Attorney for person signing for Surety Company must be attached to Bond.

CERTIFICATE AS TO CORPORATE PRINCIPAL

I, \_\_\_\_\_ certify that I am the \_\_\_\_\_ of the Corporation named as Principal in the within bond; that \_\_\_\_\_ who signed the said bond on behalf of the Principal was then the \_\_\_\_\_ of said corporation; that I know his signature, and his signature thereto is genuine; and that said bond was duly signed, sealed, and attested to for and in behalf of said corporation by authority of this governing body.

\_\_\_\_\_  
Affix  
Corporate  
Seal

Title \_\_\_\_\_

**CITY OF NORWICH  
DEPARTMENT OF PUBLIC WORKS**

**ADA SIDEWALK RAMPS  
PROJECT - 2018**

**BID # 7576**

**FEBRUARY 2018**



**PREPARED BY: CITY OF NORWICH  
DEPARTMENT OF PUBLIC WORKS**



**City of Norwich  
Department of Public Works  
ADA SIDEWALK RAMPS**

**Bid # 7576**

This project involves the removal of existing sidewalk and installation of new ADA compliant handicap accessible sidewalk ramps, and associated items at various locations in the City of Norwich. The Base Bid consists of 19 locations on City streets and State roads as follows:

Broadway & Broad Street	Providence St. & Hunters
Central Ave & Fourth Southwest	Providence St. @ Wequonnoc School West
Central Ave & Fourth Northwest	Providence St. @ Wequonnoc School East
Central Ave & Second	Main St. @ Chelsea Groton Bank
East Main St. & Palmer	Broadway & Perkins Ave Southeast
Franklin St. & Willow Northwest	Broadway & Slater Ave Southwest
Franklin St. & Willow Southwest	Laurel Hill & Center St. Northeast
Franklin St. @ Columbus Park East	Laurel Hill & Center St. Northwest
Franklin St. @ Columbus Park West	Laurel Hill & Center St. Southeast
Cliff & Cliff Place	

**Notes:** The following items should be given consideration:

- a. **Seven (7) of the locations are on a State roads as follows: East Main Street (SR 2) and Palmer Street (1EA), Laurel Hill (SR 12) and Center Street (3EA), and Providence St. (SR 169) at Wequonnoc School (3EA), and will require a CT DOT permit. The City will acquire the permit.**
- b. **Detectable Warning Device**– These warning strips are required at all handicap ramps, as detailed in the specifications. These will be paid for as a separate contract item. There are two types. The 3 ramps at Laurel Hill and Center St. will be retrofitted with a semi rigid detectable warning device as specified. All others will be placed at the time of the concrete pour.
- c. **Flaggers** – The contractor should anticipate the use of at least one flagger per day to assist with traffic control. Payment will be included on the Maintenance and Protection of Traffic item.
- d. Concrete for sidewalk and aprons will be Class ‘F’ – 4000 psi

## Quantities by Location

Location	MPT		SW		DWD		Sawcut Bituminous		Sawcut Concrete		Asphalt		CB Top		Slab W/MH	
	LS		SF		EA		LF		LF		SF		EA		SF	
Broadway & Broad Street	1		115		2		24		-		12		-		-	
Central Ave & Fourth Southwest	1		125		2		25		-		13		1		-	
Central Ave & Fourth Northwest	1		115		1		24		-		12		1		-	
Central Ave & Second	1		35		1		12		-		6		-		-	
East Main St. & Palmer	1		54		1		14		6		7		-		-	
Franklin St. & Willow Northwest	1		48		1		22		-		11		-		-	
Franklin St. & Willow Southwest	1		65		1		22		7		11		-		-	
Franklin St. @ Columbus Park East	1		125		1		26		-		13		-		-	
Franklin St. @ Columbus Park West	1		115		1		18		-		9		-		-	
Providence St. & Hunters	1		160		1		32		-		16		-		-	
Providence St. @ Wequonnoc School West	1		115		1		-		-		0		-		-	
Providence St. @ Wequonnoc School East	1		70		1		20		12		10		-		-	
Main St. @ Chelsea Groton Bank	1		50		1		14		-		7		-		-	
Broadway & Perkins Ave Southeast	1		150		2		32		-		16		-		-	
Broadway & Slater Ave Southwest	1		130		2		30		-		15		-		-	
Cliff & Cliff Place	1		45		1		23		-		12		-		-	
Laurel Hill & Center St. Northeast	1		27		1		24		-		12		1		28	
Laurel Hill & Center St. Northwest	1		-		1		26		-		13		-		52	
Laurel Hill & Center St. Southeast	1		102		1		32		-		16		1		33	
<b>TOTALS</b>	<b>19</b>		<b>1646</b>		<b>23</b>		<b>420</b>		<b>25</b>		<b>211</b>		<b>4</b>		<b>113</b>	

## SITE CONSTRUCTION NOTES

1. Although no pre-bid conference is planned on this project, the contractor should visit each location to become familiar with the work areas. The construction limit at each location is noted on the plans.
2. The contractor shall notify "Call Before You Dig" at 1-800-922-4455 at least three (3) business days prior to commencing any site excavation.
3. The contractor shall coordinate all activities with all adjacent property owners prior to commencing any demolition or construction work.
4. The contractor shall coordinate his work with the Norwich Public Utilities Water and Gas Divisions to ensure that existing curb boxes are adjusted properly to grade and are properly aligned before pouring new sidewalks.
5. The contractor shall have 45 days from the notification of award to complete the work called for on the base bid. Failure to satisfactorily complete this work on or before this date will result in a \$100.00 per day penalty for every calendar day beyond this date until such time as the City determines that the work is substantially complete.
6. Quantities and lengths on this plan are approximate. Payment will be determined by actual field measurements by the contractor and DPW. Sidewalk widths made wider than the width specified on the plan will not be paid for unless approved by DPW.
7. The contractor shall be responsible for providing adequate and safe traffic control and circulation during the entire project duration. The contractor shall supply and install all necessary traffic barricades, signage, and flagmen, under the Maintenance and Protection of Traffic item, to ensure the safety and well being of the general public, private property owners and all vehicular and pedestrian traffic.
8. The contractor shall be responsible for maintaining a clean work area during and after each workday. No debris or other construction materials shall be left within the public way at the close of each workday.
9. No excavations, trenches, holes or underground structures shall be left open overnight, and shall be adequately backfilled or securely closed at the end of each workday.
10. All paving and excavation work shall be in accordance with the State of Connecticut DOT Standard Specifications for Roads, Bridges and Incidental Construction, Form 817.
11. All surfaces shall be graded such that positive gravity drainage occurs from all surface points. No ponding or "bird baths" shall be permitted anywhere within the new walkway or gutterlines.
12. The contractors shall protect newly poured sidewalk from any damage caused by vandalism. The City will reject any slabs that have been marred prior to the concrete sufficiently setting. Such slabs must be removed and satisfactorily replaced at the contractor's expense. The contractor is encouraged to only pour concrete in the a.m. hours.

## **1. MAINTENANCE AND PROTECTION OF TRAFFIC**

This bid item shall include but not be limited to all measures used to maintain traffic flow in the project area, to establish detours if required, to coordinate efforts with the local police department, to provide warning lights, barricades, traffic drums, etc. all labor and material incidental thereto. The attached CT DOT Construction Traffic Control Plans shall be used on this project at any residences that are located on State routes.

### **DESCRIPTION:**

The Contractor shall maintain traffic in the project area to the satisfaction of the City. The Contractor must maintain pedestrian and vehicular traffic and permit access to businesses, residences, and intersecting streets. Where detours will be required, the City may require the Contractor to submit a proposed detour plan for all portions of the work to the City and to the applicable local agencies. This submittal shall be made at least seven days prior to commencing construction. It shall be the sole responsibility of the Contractor to notify local agencies (including but not limited to the Police and Fire Departments) at least 72 hours in advance of changes in traffic patterns due to reduction of pavement widths or closing of streets. The Contractor shall supply, install, maintain, adjust, move, relocate, and store all signs, suitably lighted barricades, traffic cones and traffic delineators, as necessary to carry out the traffic routing plan and maintain vehicular and pedestrian traffic. All of this work shall meet with the requirements of the local agencies and the City.

The Contractor shall furnish, light, and maintain such signs as may be directed, or may be necessary for the safe regulation, or convenience of traffic. Said signs will be as specified on the contract plans or elsewhere herein, or if not specified, they shall be adequate for the regulation, safety and convenience of traffic. The Contractor shall provide, erect, and maintain suitably lighted barricades, warning lights, etc., as needed, or as directed in order to keep people, animals and vehicles from excavations, obstacles, etc. The Contractor may be required to employ traffic men and take other such reasonable means or precautions as the City may direct, or as may be needed to prevent damage or injury to persons, vehicles, or other property and to minimize the inconvenience and danger to the public by his construction operations. He shall arrange his operation to provide access to properties along the street including temporary bridges to driveways, and provide access to fire hydrants, manholes, gate boxes, or other utilities. Whenever any trench obstructs traffic in or to any public street, private driveway, or property entrance, the Contractor shall take such steps as required to maintain necessary traffic and access including temporary bridging if required. The Contractor shall confine his occupancy of public or traveled ways to the smallest space compatible with the efficient and safe performance of the work contemplated by the contract.

The Contractor shall observe and obey all local and state laws, ordinances, regulations and permits in relation to the obstruction of streets and highways, keeping passageways open and protecting traffic where there may be danger from construction activities.

Suitable light barriers or barricades shall be furnished by the Contractor and put up and maintained at all times during the night or daytime, around all open ditches, trenches, excavations, or other work potentially dangerous to traffic. Such barricades shall be constructed of 2" x 8" rough lumber, securely supported and braced at least 3' high above the ground. Barricades shall be placed on all sides and throughout the entire length and breadth of all open ditches, trenches, excavations, or other work that must be barred to the general public. Barricades shall be properly painted to the satisfaction of the City in order to retain a high degree of visibility to vehicular and pedestrian traffic.

The Contractor shall furnish and securely fasten flashing units to signs, barricades, and other objects in such numbers and for such lengths of time as are required for the maintenance and protection of traffic, or as the Engineer may order. The flasher shall be in operation during all hours between sunset and sunrise, and during periods of low visibility. The Contractor shall maintain, relocate and operate barricades and flashers throughout

## **1. MAINTENANCE AND PROTECTION OF TRAFFIC continued**

the life of the contract. No special payment will be made for barricades or flashers. Should the Contractor or his employees neglect to set out and maintain barricades or lights, as required in these specifications, the City immediately, and without notice, may furnish, install and maintain barricades or lights. The cost thereof shall be borne by the Contractor and may be deducted from any amount due or to become due to the Contractor under this contract.

If the Contractor's operations or occupancy of any public street or highway, or the uneven surfaces over any trenches being maintained by the Contractor shall interfere with the removal or sanding of snow or ice by the public authorities or adjoining land owners, in an ordinary manner with regular highway equipment, the contractor shall be required to perform such services for the public authorities or adjoining owners without charge. If the contractor fails to do so, he shall reimburse the said authorities or adjoining owners for any additional cost to them for doing such work occasioned by conditions arising from the Contractor's operations or occupancy, or trench surfaces, together with any damage to the equipment of said parties by those conditions, or claims of any parties for damage or injury or loss by reason of failure to remove snow or ice or to sand icy spots under these conditions.

### **BASIS OF PAYMENT**

This item will be paid for at the Contract unit price, EA per location, for "Maintenance and Protection of Traffic".

## 2. CONCRETE SIDEWALK & HANDICAP RAMPS

### **DESCRIPTION:**

Under these items the Contractor shall install a 5" thick concrete sidewalk, with a 12" x 8" haunch at ramps, upon an 8" gravel base as shown on the plans or as directed by the Engineer. Installing Detectable Warning Strips for new construction shall be performed in conjunction with the installation of the concrete sidewalk and handicap ramps in the locations and to the dimensions and details shown on the plans or as ordered by the Engineer. However, material for this item shall be paid for separately, under a different contract item.

### **MATERIALS:**

Concrete shall be Class "F" and have a minimum 28-day compressive strength of 4000-psi water, cement ratio of 0.44 and a minimum cementitious material of 658-lbs./cubic yard in accordance with Section 4.01 and M.03 of the CT DOT Form 817.

The gravel base shall conform to Section M.02.06, Grading A.

### **CONSTRUCTION METHODS:**

Construction shall generally conform to the following:

1. **Excavation:** Excavation, including removal of any existing sidewalk, shall be made to the required depths below the finished grade, as shown on the plans or as directed. All soft and yielding materials shall be removed and replaced with suitable material.
2. **Gravel or Reclaimed Miscellaneous Aggregate Base:** The gravel base shall be placed in layers not over 6 inches in depth and to such a depth that after compaction it shall be at the specified depth below the finished grade of the walk. The base shall be wetted and rolled or tamped after the spreading of each layer.
3. **Forms:** Forms shall be of metal or wood, straight, free from warp and of sufficient strength to resist springing from the pressure of the concrete. If wood, they shall be of 2-inch surfaced plank except that at sharp curves thinner material may be used. If of metal, they shall be of approved section and shall have a flat surface on the top. Forms shall be of a depth equal to the depth of the sidewalk. Forms shall be securely staked, braced, and held firmly to the required line and grade and shall be sufficiently tight to prevent leakage of concrete. All forms shall be cleaned and oiled or wetted before concrete is placed against them. Sheet metal templates 1/8-inch in thickness, of the full depth and width of the walk, shall be spaced at intervals of 12 feet or as directed. If the concrete is placed in alternate sections, these templates shall remain in place until concrete has been placed on both sides of the template. As soon as the concrete has obtained its initial set the templates shall be removed.

The concrete walk shall be broom finished. Expansion joints shall be installed every 15 feet and dummy joints shall be formed every 5 feet.

The Detectable Warning Devices for new construction shall be set directly in poured concrete according to the plans or as directed by the Engineer, or shall be retro-fitted per the manufacturer's instructions. The contractor shall place two twenty five (25) pound blocks or sandbags on each tile to prevent the tile from floating after installation in wet concrete.

The contractor is responsible for removing any material splatters or debris arising from the installation of the tile.

## 2. CONCRETE SIDEWALK & HANDICAP RAMPS **continued**

The Contractor shall use watchmen, plastic coverings, and any other means necessary to prevent damage to freshly poured walks until the concrete has set firmly. When concrete sidewalks are poured monolithically with concrete curbing, the curbing shall be installed in conformance with those specifications. Where noted on the plans, handicapped ramps shall be installed in conformance with typical detail or as directed by the Engineer.

Where noted on the plan or as directed by the Engineer, sign posts and other objects must be reset into sleeves. The sleeves must be set, prior to the concrete pour.

### **METHOD OF MEASUREMENT:**

This item will be measured by the number of square feet of concrete sidewalks poured and accepted in place. The City reserves the right to not accept areas that have been damaged. In areas where the curbing has been poured monolithically with the sidewalk, the curbing will be paid for elsewhere. The Detectable Warning Strip will be paid for under a separate item. All materials, equipment, tools and labor incidental thereto shall be included in the Bid Price for Concrete Sidewalk.

### **BASIS OF PAYMENT:**

This work will be paid for under the square foot item "Concrete sidewalk and Handicap Ramp":

Which price shall include all tools, equipment, labor, and material incidental thereto. This unit price shall include, among other things, the cost of the following items that will not be paid for separately:

- a. excavation and disposal of material
- b. formation of sub-grade
- c. furnishing, laying, and compacting gravel base
- d. furnishing, pouring, and finishing concrete
- e. installation of expansion and dummy joints
- f. sign post and other object installation
- g. protection of freshly poured concrete until setup
- h. loam and seed adjacent areas that have been disturbed

- 3. CAST IN PLACE ARMOR-TILE**
- 4. SURFACE APPLIED ARMOR-TILE**

**DESCRIPTION:**

The contractor shall furnish Detectable Warning Devices for use at all handicap ramps as noted in the plans and specifications, or as directed by the Engineer in the field. Surface Applied Armor Tile shall be utilized on the precast slabs with the manhole frame and cover.

**MATERIALS:**

The Detectable Warning Device shall be a prefabricated cast in place Armor-Tile for the application designated as manufactured from Engineered Plastics Inc., 300 International Drive, Suite 100, Williamsville, NY 14221, telephone number (800) 682-2525, or the approved equal from ADA Fabricators, Inc., PO Box 179, North Billerica, MA 01862, telephone number (978) 262-9900. The tile shall conform to the dimensions shown on the plans and have a brick red homogenous color throughout in compliance with Federal Standard 595A Color #22144, or approved equal. For retrofit applications, the Surface Applied Armor-Tile shall be installed, at the location approved by the Engineer, and in compliance with the manufacturer's instructions.

**BASIS OF PAYMENT:**

This item will be paid for at the contract unit price per each for "Cast in Place Armor-Tile ", and at the contract unit price per each for the retrofit locations "Surface Applied Armor-Tile". The price shall include all tools, equipment, labor, and material incidental thereto for the furnishing and installation of these items.

## **5. CONCRETE SEALANT**

**DESCRIPTION**

Under this item, the contractor shall furnish and place a concrete sealant on the new concrete sidewalks and ramps.

**MATERIALS**

The contractor shall utilize PS101 Multi-surface Penetrating Sealer by Concrete Sealers USA of Brookfield, WI, or an as equal product.

**CONSTRUCTION METHODS**

The sealant shall be applied in accordance with the manufacturer's instructions, no earlier than 7 days after the concrete has been placed. The contractor will be required to power-wash the sidewalk and apply the sealant once these areas have dried.

**BASIS OF PAYMENT**

This item will be paid for as at the square foot unit price for "Concrete Sealant", and shall include all labor, equipment and materials incidental thereto.



## **6. SAW CUT BITUMINOUS PAVEMENT**

### **DESCRIPTION**

Under this item, the contractor shall saw cut the roadway pavement in accordance with the plans and specifications, or as directed by the Engineer.

### **CONSTRUCTION METHODS**

The bituminous pavement shall be cut along neat lines and to a depth indicated on the plans or typical sections. A road saw, approved by the Engineer, shall be used for cutting the bituminous pavement. After the existing bituminous overlay has been saw cut through, the contractor may use pry bars, pneumatic tools, or other methods approved by the Engineer to pry loose the existing pavement and break it up as necessary to remove it.

Any existing pavements and curbs not indicated to be removed, that are damaged by the contractor, shall be repaired by the contractor at no additional cost to the Owner.

### **METHOD OF MEASUREMENT**

The quantity to be measured will be the number of feet of saw cutting done in accordance with the plans and specifications and the direction of the Engineer.

### **BASIS OF PAYMENT**

This item will be paid for as at the linear foot unit price for "Saw Cut Bituminous Pavement", and shall include all labor, materials and equipment necessary to complete the work.

## **7. SAW CUT CONCRETE SIDEWALK**

### **DESCRIPTION**

Under this item, the contractor shall saw cut the concrete sidewalk in accordance with the plans and specifications, or as directed by the Engineer.

### **CONSTRUCTION METHODS**

The concrete sidewalk pavement shall be cut along neat lines and to a depth indicated on the plans or typical sections. A power saw, approved by the Engineer, shall be used for cutting the concrete sidewalk. After the existing concrete has been saw cut through, the contractor may use pry bars, pneumatic tools, or other methods approved by the Engineer to pry loose the existing pavement and break it up as necessary to remove it.

Any existing sidewalk not indicated to be removed that is damaged by the contractor shall be repaired by the contractor at no additional cost to the Owner.

### **METHOD OF MEASUREMENT**

The quantity to be measured will be the number of feet of saw cutting done in accordance with the plans and specifications and the direction of the Engineer.

### **BASIS OF PAYMENT**

This item will be paid for as at the linear foot unit price for "Saw Cut Concrete Sidewalk", and shall include all labor, materials and equipment necessary to complete the work.

## **8. REPLACE CATCH BASIN TOP**

### **DESCRIPTION:**

Under this item the Contractor shall replace existing catch basin tops with Type C-M tops, as shown on the plan or as directed by the Engineer, to match the line and grade of the proposed curb. The contractor shall furnish and install a catch basin top of the type specified, complete in place, per the attached details.

### **MATERIAL:**

Brick shall conform to Section M.08.02. Mortar shall conform to Section M.11.04. Bituminous pavement shall conform to

### **CONSTRUCTION METHODS:**

The Construction shall conform to Section 5.07.03.

### **BASIS OF PAYMENT:**

This item will be paid for at the contract unit price each for "Replace Catch Basin Top", which price shall include all tools, equipment, labor and material incidental thereto, up to an including reconstruction to a vertical depth of 3 feet.

This unit price shall include, among other incidentals, the cost of the following:

1. cutting pavement and excavation
2. removal of pavement
3. disposal of material and old catch basin top
4. reconstruction of basin to a depth of 3 feet if required
5. purchase of catch basin top
6. setting new top
7. backfilling and compaction of processed gravel
8. bituminous concrete patching of the roadway

## **9. BITUMINOUS CONCRETE PATCHING**

### **DESCRIPTION:**

Work under this item shall consist of the placement of a smooth and dense bituminous concrete mixture with a uniform texture for the purpose of providing a smooth transition between the new ramp and the existing adjacent roadway. Work under this item is subject to approval by the Engineer, prior to the commencement of work at each location.

### **MATERIALS:**

The materials for Asphalt Patch shall conform to the requirements of Section M.04, Class 2 of the CT DOT Form 817, 2016.

### **BASIS OF PAYMENT:**

This work will be paid for at the contract unit price per square foot for "Asphalt Patch" complete and accepted in place, which price shall include all materials, equipment, tools, excavation, backfill, disposal of surplus material and labor incident thereto.

## **10. PRECAST CONCRETE SLAB WITH MANHOLE FRAME AND COVER**

### **DESCRIPTION:**

Under this item, the Contractor shall furnish and install precast concrete slabs with a 24 inch manhole frame and cover, in the locations shown on the plans, or as directed by the Engineer.

### **MATERIALS:**

Concrete shall be Class "F" and have a minimum 28-day compressive strength of 4000-psi water, cement ratio of 0.44 and a minimum cementitious material of 658-lbs./cubic yard in accordance with Section 4.01 and M.03 of the CT DOT Form 817.

Reinforcing steel shall meet the requirements of Article M.06.01

Metal for Drainage Structures: Metal manhole frames, extensions, covers, and gratings shall be cast iron, cast steel, structural steel or malleable iron conforming to the requirements of the plans. Covers and gratings shall bear uniformly on their supports. Cast iron shall conform to the requirements of AASHTO M 105, Class 25 for the frames and Class 30 for grates. Cast steel shall conform to the requirements of ASTM A27, Grade optional, and shall be thoroughly annealed.

### **CONSTRUCTION METHODS:**

The precast units shall be placed on a prepared subbase and shall be installed to the lines and grades given, and in accordance with the dimensions and details shown on the plans.

1. Precast Units: Concrete slabs shall be precast in an approved plant in accordance with the applicable requirements of Sub-articles 5.14.03-4, 6, 7, 8 and 15 supplemented as follows: Forms for precast concrete units shall be of substantial construction, lined so as to produce a smooth dense surface with a uniform appearance. Form oil shall be a non-staining type. Air holes on exposed surfaces shall be filled immediately after removal of the forms to the satisfaction of the Engineer.
2. The precast slabs shall be placed on a prepared subbase and shall be installed to the lines and grades given and in accordance with the dimensions and details shown on the plans
3. Backfilling: The backfilling shall be completed to the lines shown on the plans, or as ordered, by filling to the required elevation with approved material which shall be placed in layers of not over 6 in deep with each layer compacted until firm and solid.
4. Whenever a slab is being constructed adjacent to areas open to traffic, the Contractor shall complete the installation by the close of each day's work so as to prevent any hazard that would be caused by leaving it open.
5. Precast slabs that have been damaged shall be removed from the project and replaced at the Contractor's expense.
6. Precast units shall be coated with a penetrating sealer protective compound that meets the requirements of Article M.03.09.

### **BASIS OF PAYMENT:**

This work will be paid for at the contract unit price per square foot for "Precast Concrete Slab with Manhole" complete and accepted in place, which price shall include all materials, equipment, tools, excavation, backfill, disposal of surplus material and labor incident thereto.

**NOTE:** The contractor is responsible for reviewing the site location and for providing the fabricator with the exact dimensions of each slab.

### NOTES FOR TRAFFIC CONTROL PLANS

1. IF A TRAFFIC STOPPAGE OCCURS IN ADVANCE OF SIGN (A), THEN AN ADDITIONAL SIGN (A) SHALL BE INSTALLED IN ADVANCE OF THE STOPPAGE.
2. SIGNS (AA), (A) AND (D) SHOULD BE OMITTED WHEN THESE SIGNS HAVE ALREADY BEEN INSTALLED TO DESIGNATE A LARGER WORK ZONE THAN THE WORK ZONE THAT IS ENCOMPASSED ON THIS PLAN.
3. SEE TABLE #1 FOR ADJUSTMENT OF TAPERS IF NECESSARY.
4. A CHANGEABLE MESSAGE SIGN MAY BE UTILIZED ONE HALF TO ONE MILE IN ADVANCE OF THE LANE CLOSURE TAPER.
5. IF THIS PLAN REMAINS IN CONTINUOUS OPERATION FOR MORE THAN 72 HOURS, THEN TRAFFIC DRUMS SHALL BE USED IN PLACE OF TRAFFIC CONES.
6. ANY LEGAL SPEED LIMIT SIGNS WITHIN THE LIMITS OF A ROADWAY / LANE CLOSURE AREA WILL BE COVERED WITH AN OPAQUE MATERIAL WHILE THE CLOSURE IS IN EFFECT AND UNCOVERED WHEN THE ROADWAY / LANE CLOSURE IS REOPENED TO ALL LANES OF TRAFFIC.
7. IF THIS PLAN REMAINS IN CONTINUOUS OPERATION FOR MORE THAN 36 HOURS, THEN THE EXISTING CONFLICTING PAVEMENT MARKINGS SHALL BE ERADICATED OR COVERED AND TEMPORARY PAVEMENT MARKINGS THAT DEPICT THE PROPER TRAVEL PATHS SHALL BE INSTALLED.
8. DISTANCES BETWEEN SIGNS IN THE ADVANCE WARNING AREA MAY BE REDUCED TO 200' ON LOW SPEED URBAN ROADS (SPEED LIMIT < 40 MPH).
9. FOR LANE CLOSURES ONE (1) MILE OR LONGER, A "REDUCE SPEED TO 45 MPH" SIGN SHALL BE PLACED AT THE ONE MILE POINT AND AT EACH MILE THEREAFTER.
10. IF THIS PLAN IS TO REMAIN IN OPERATION DURING THE HOURS OF DARKNESS, INSTALL BARRICADE WARNING LIGHTS - HIGH INTENSITY ON ALL POST-MOUNTED DIAMOND SIGNS IN THE ADVANCE WARNING AREA.
11. A CHANGEABLE MESSAGE SIGN SHALL BE INSTALLED ONE HALF TO ONE MILE IN ADVANCE OF THE LANE CLOSURE TAPER.

REV'D 1-02



CONNECTICUT  
DEPARTMENT OF TRANSPORTATION  
BUREAU OF ENGINEERING &  
HIGHWAY OPERATIONS  
DIVISION OF TRAFFIC ENGINEERING

CONSTRUCTION  
TRAFFIC CONTROL PLAN  
NOTES

NOTES.DGN

**SERIES 16 SIGNS**

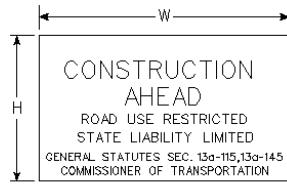

		W	H
16-E	80-1605	84" x 60"	
16-H	80-1608	60" x 42"	
16-M	80-1613	30" x 24"	

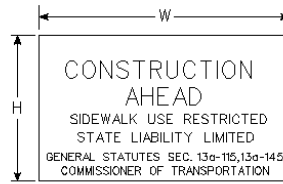

		W	H
16-S	80-1619	48" x 30"	

THE 16-S SIGN SHALL BE USED ON ALL PROJECTS THAT REQUIRE SIDEWALK RECONSTRUCTION OR RESTRICT PEDESTRIAN TRAVEL ON AN EXISTING SIDEWALK.

SERIES 16 SIGNS SHALL BE INSTALLED IN ADVANCE OF THE TRAFFIC CONTROL PATTERNS TO ALLOW MOTORISTS THE OPPORTUNITY TO AVOID A WORK ZONE. SERIES 16 SIGNS SHALL BE INSTALLED ON ANY MAJOR INTERSECTING ROADWAYS THAT APPROACH THE WORK ZONE. ON LIMITED- ACCESS HIGHWAYS, THESE SIGNS SHALL BE LOCATED IN ADVANCE OF THE NEAREST UPSTREAM EXIT RAMP AND ON ANY ENTRANCE RAMP PRIOR TO OR WITHIN THE WORK ZONE LIMITS.

THE LOCATION OF SERIES 16 SIGNS CAN BE FOUND ELSEWHERE IN THE PLANS OR INSTALLED AS DIRECTED BY THE ENGINEER.

SIGNS 16-E AND 16-H SHALL BE POST MOUNTED.

SIGN 16-E SHALL BE USED ON ALL EXPRESSWAYS.

SIGN 16-H SHALL BE USED ON ALL RAMP, OTHER STATE ROADWAYS, AND MAJOR TOWN/CITY ROADWAYS.

SIGN 16-M SHALL BE USED ON OTHER TOWN ROADWAYS.

**REGULATORY SIGN "ROAD WORK AHEAD, FINES DOUBLED"**

THE REGULATORY SIGN "ROAD WORK AHEAD, FINES DOUBLED" SHALL BE INSTALLED FOR ALL WORK ZONES THAT OCCUR ON ANY STATE HIGHWAY IN CONNECTICUT WHEN THERE ARE WORKERS ON THE HIGHWAY OR WHEN THERE IS OTHER THAN EXISTING TRAFFIC OPERATIONS.

**THE "ROAD WORK AHEAD, FINES DOUBLED" REGULATORY SIGNS SHALL NOT BE INSTALLED ON TOWN ROADS.**

THE "ROAD WORK AHEAD FINES DOUBLED" REGULATORY SIGN SHALL BE PLACED AFTER THE SERIES 16 SIGN AND IN ADVANCE OF THE "ROAD WORK AHEAD" SIGN.

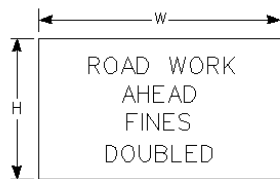

		W	H
31-1906		48" x 42"	

**"END ROAD WORK" SIGN**

THE LAST SIGN IN THE PATTERN MUST BE THE "END ROAD WORK" SIGN.

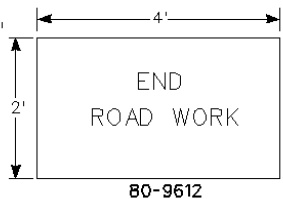

80-9612

REV'D 1-02



CONNECTICUT  
DEPARTMENT OF TRANSPORTATION  
BUREAU OF ENGINEERING &  
HIGHWAY OPERATIONS  
DIVISION OF TRAFFIC ENGINEERING

CONSTRUCTION  
TRAFFIC CONTROL PLAN  
REQUIRED SIGNS

APPROVED J. Carey DATE 1-02  
PRINCIPAL ENGINEER

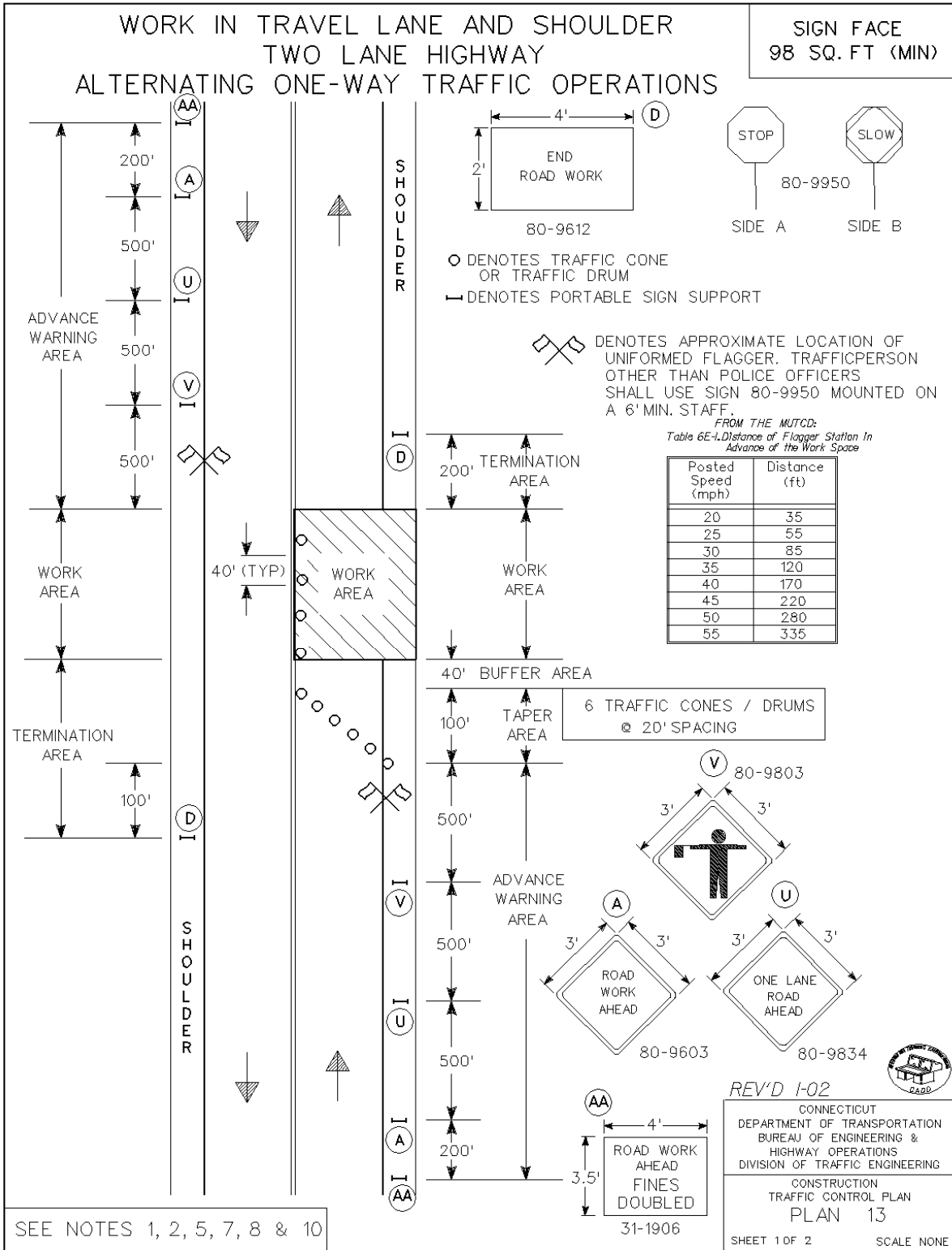

# WORK IN TRAVEL LANE AND SHOULDER TWO LANE HIGHWAY ALTERNATING ONE-WAY TRAFFIC OPERATIONS

## HAND SIGNAL METHODS TO BE USED BY UNIFORMED FLAGGERS

THE FOLLOWING METHODS FROM SECTION 6E.04 FLAGGER PROCEDURES IN THE "MANUAL ON UNIFORM TRAFFIC CONTROL DEVICES" SHALL BE USED BY UNIFORMED FLAGGERS WHEN DIRECTING TRAFFIC THROUGH A WORK AREA. THE STOP/SLOW SIGN PADDLE ( SIGN NO. 80-9950) SHOWN ON THE TYPICAL DETAIL SHEET ENTITLED "SIGNS FOR CONSTRUCTION AND PERMIT OPERATIONS" SHALL BE USED.

A. TO STOP TRAFFIC

TO STOP ROAD USERS, THE FLAGGER SHALL FACE ROAD USERS AND AIM THE STOP PADDLE FACE TOWARD ROAD USERS IN A STATIONARY POSITION WITH THE ARM EXTENDED HORIZONTALLY AWAY FROM THE BODY. THE FREE ARM SHALL BE HELD WITH THE PALM OF THE HAND ABOVE SHOULDER LEVEL TOWARD APPROACHING TRAFFIC.

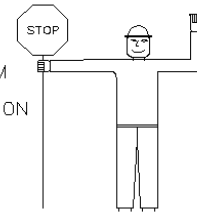

B. TO DIRECT TRAFFIC TO PROCEED

TO DIRECT STOPPED ROAD USERS TO PROCEED, THE FLAGGER SHALL FACE ROAD USERS WITH THE SLOW PADDLE FACE AIMED TOWARD ROAD USERS IN A STATIONARY POSITION WITH THE ARM EXTENDED HORIZONTALLY AWAY FROM THE BODY. THE FLAGGER SHALL MOTION WITH THE FREE HAND FOR ROAD USERS TO PROCEED.

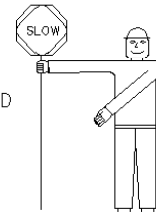

C. TO ALERT OR SLOW TRAFFIC

TO ALERT OR SLOW TRAFFIC, THE FLAGGER SHALL FACE ROAD USERS WITH THE SLOW PADDLE FACE AIMED TOWARD ROAD USERS IN A STATIONARY POSITION WITH THE ARM EXTENDED HORIZONTALLY AWAY FROM THE BODY. TO FURTHER ALERT OR SLOW TRAFFIC, THE FLAGGER HOLDING THE SLOW PADDLE FACE TOWARD ROAD USERS MAY MOTION UP AND DOWN WITH THE FREE HAND, PALM DOWN.

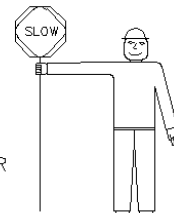

SEE NOTES 1, 2, 5, 7, 8 & 10

REV'D 1-02



CONNECTICUT  
DEPARTMENT OF TRANSPORTATION  
BUREAU OF ENGINEERING &  
HIGHWAY OPERATIONS  
DIVISION OF TRAFFIC ENGINEERING

CONSTRUCTION  
TRAFFIC CONTROL PLAN  
PLAN 13  
SHEET 2 OF 2      SCALE NONE

APPROVED J. Carey DATE 1-02  
PRINCIPAL ENGINEER

# WORK IN SHOULDER - TWO LANE HIGHWAY

SIGN FACE  
71 SQ. FT (MIN)

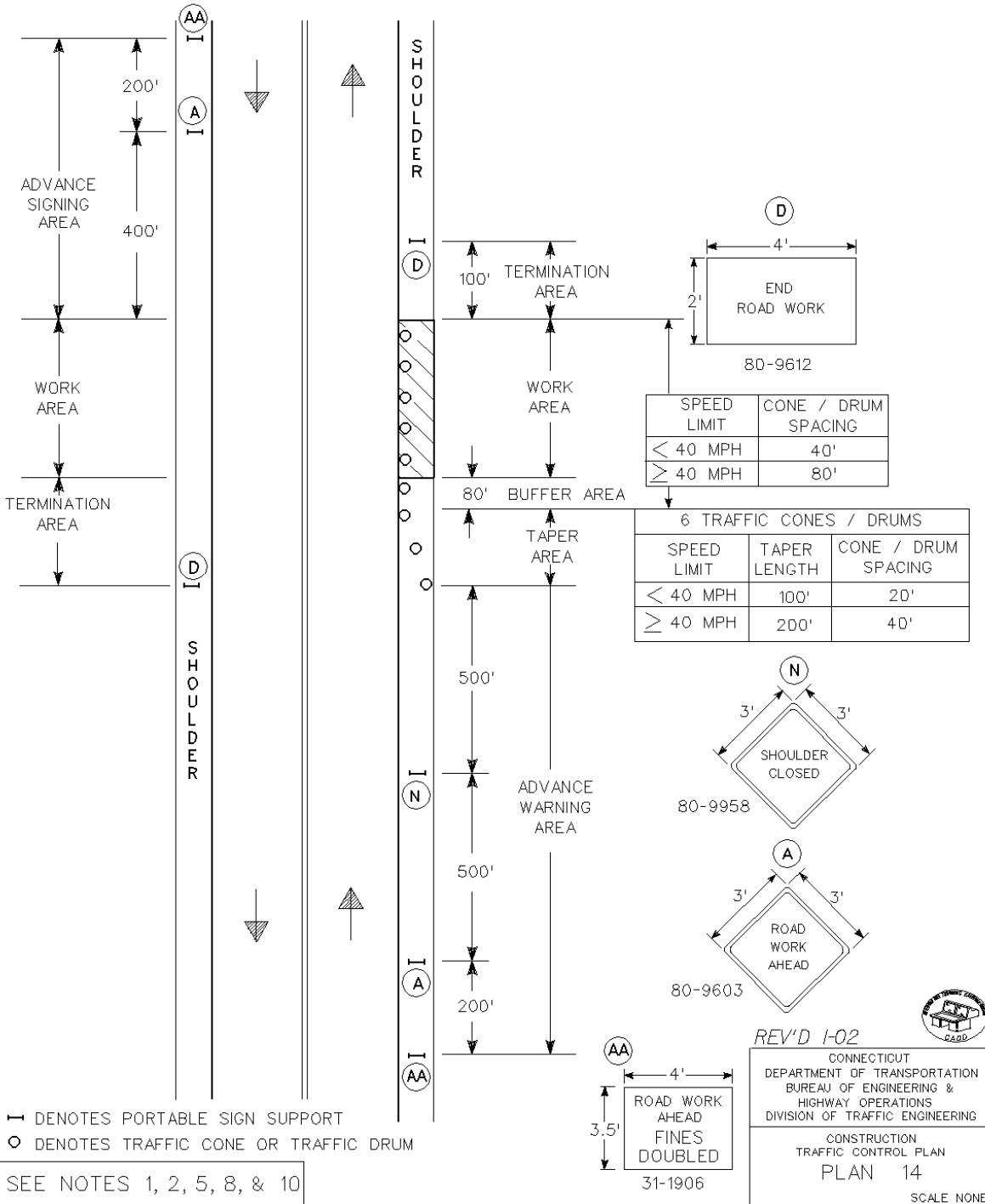



# WORK IN TRAVEL LANE AND SHOULDER TWO LANE HIGHWAY

SIGN FACE  
62 SQ. FT (MIN)

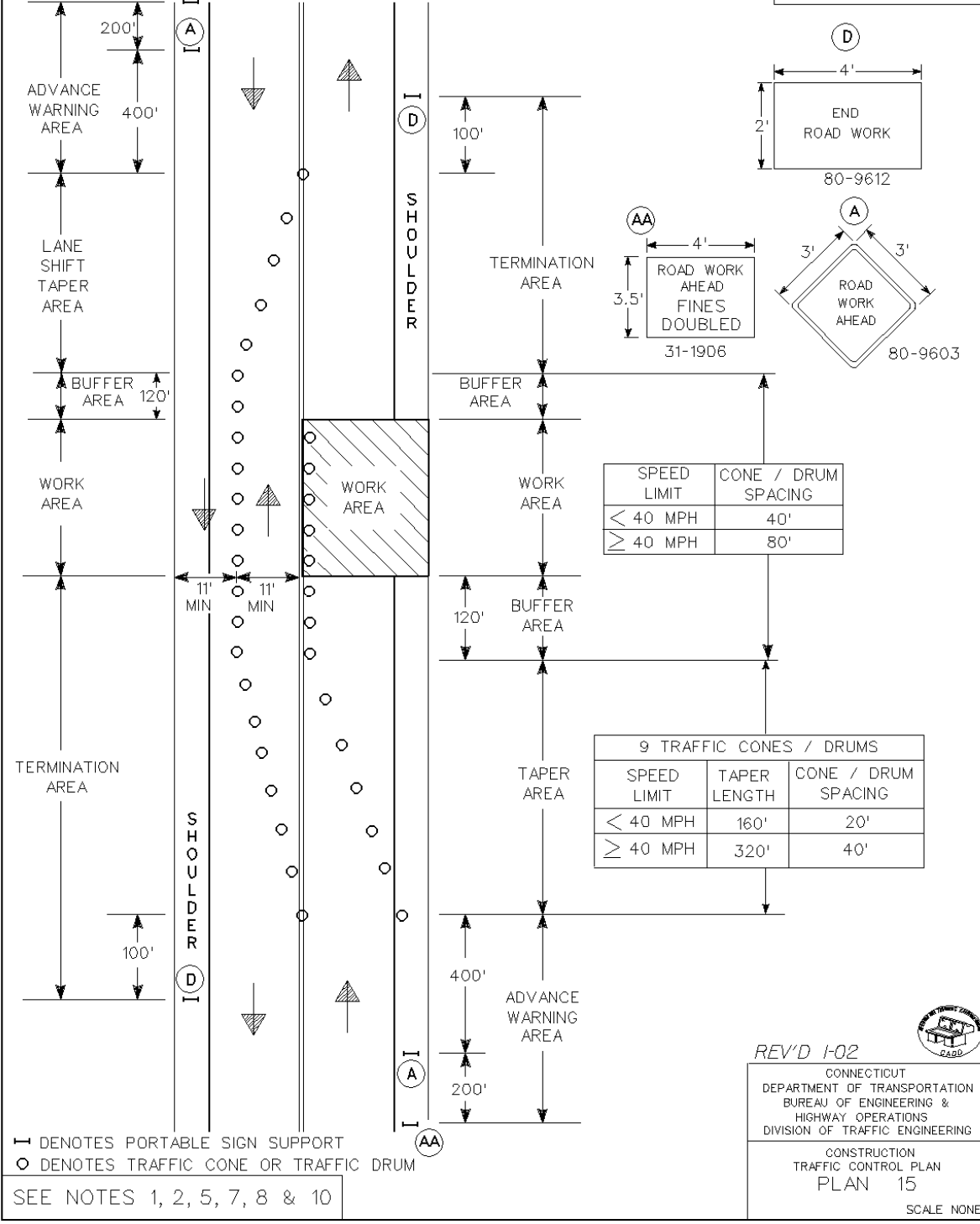

REV'D I-02

CONNECTICUT  
 DEPARTMENT OF TRANSPORTATION  
 BUREAU OF ENGINEERING &  
 HIGHWAY OPERATIONS  
 DIVISION OF TRAFFIC ENGINEERING

CONSTRUCTION  
 TRAFFIC CONTROL PLAN  
 PLAN 15

SCALE NONE

APPROVED J. Carey DATE I-02  
PRINCIPAL ENGINEER

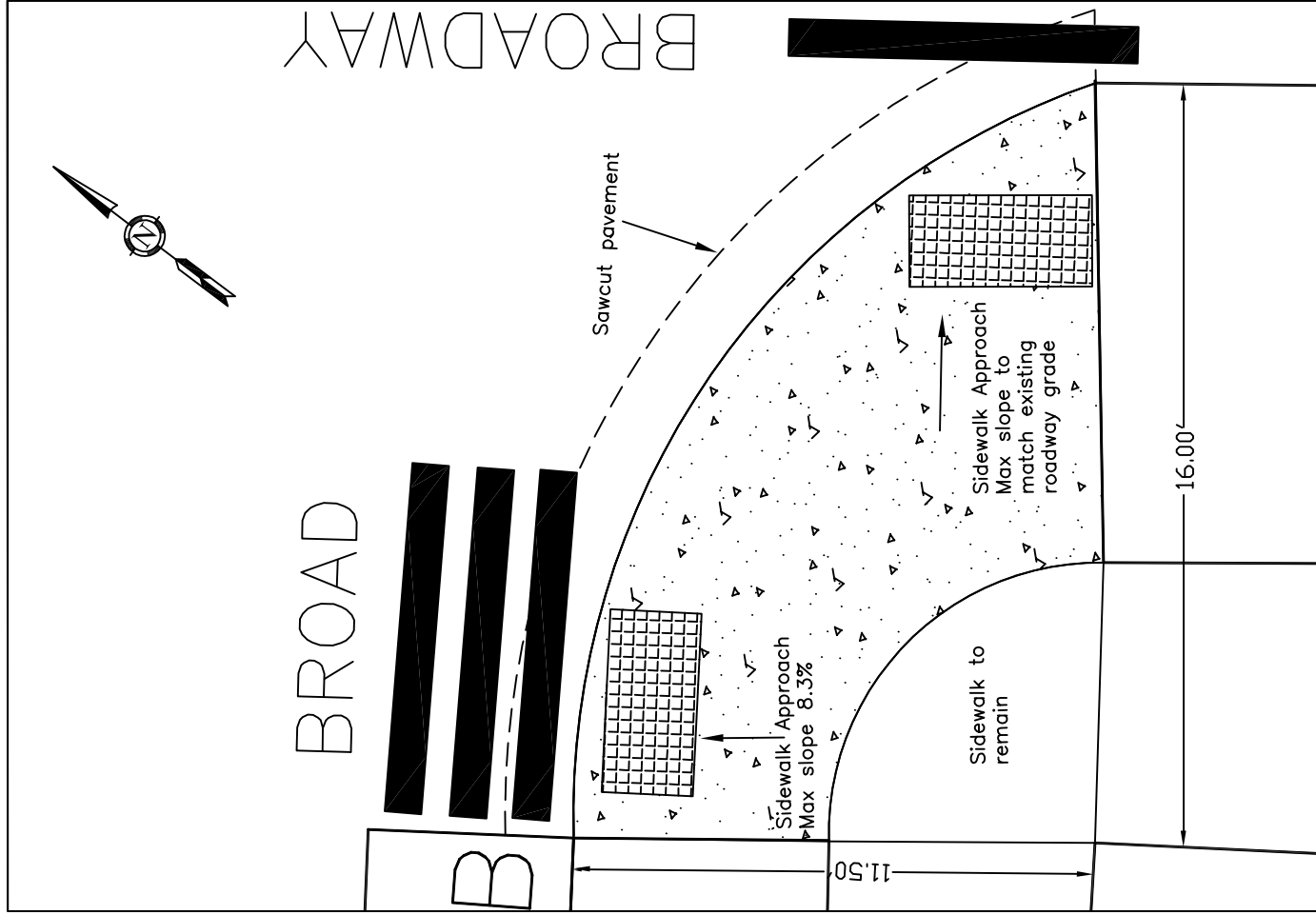

Broadway @ Broad Street (SW Corner)

Scale 1":4'

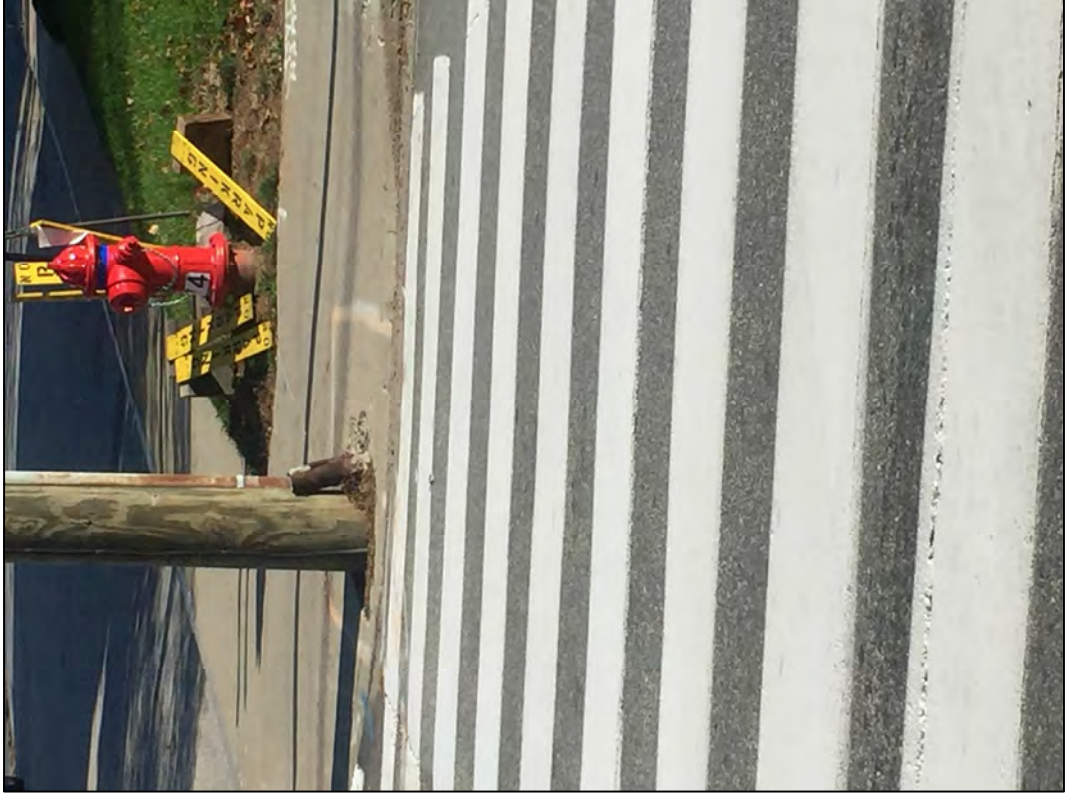
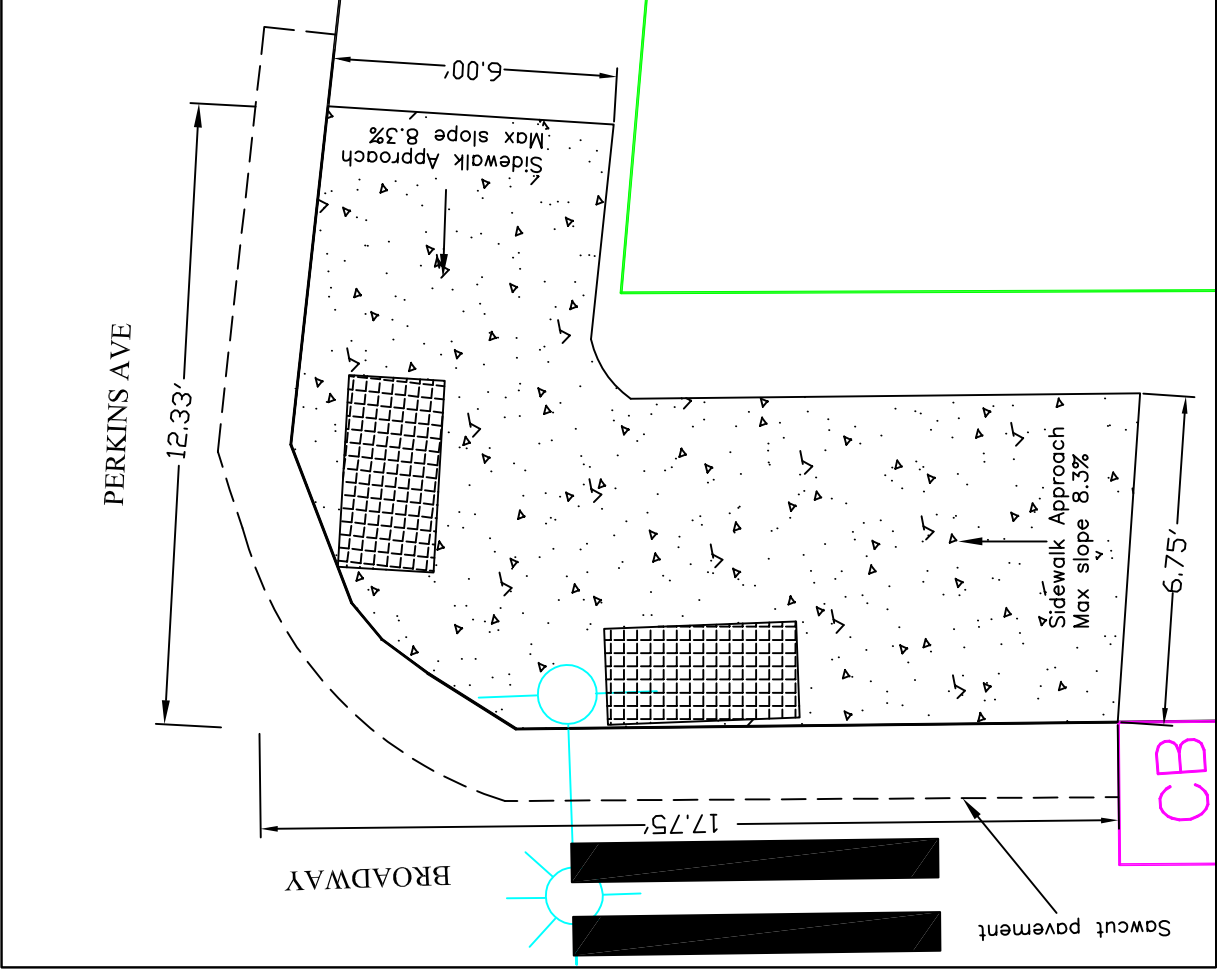

Broadway @ Perkins (South Side)

Scale 1":4'

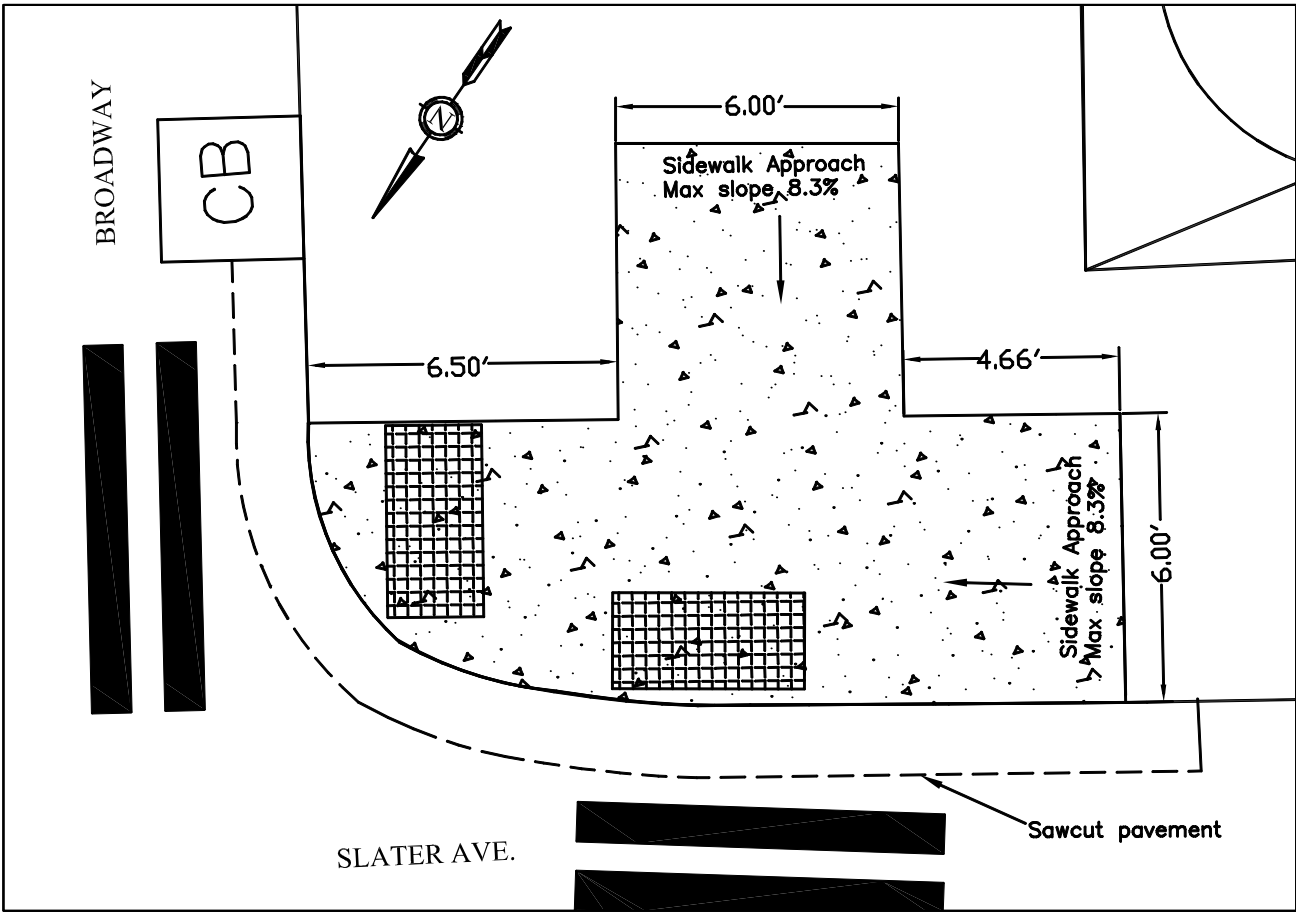

Broadway @ Slater (Southwest Side)

Scale 1":4'

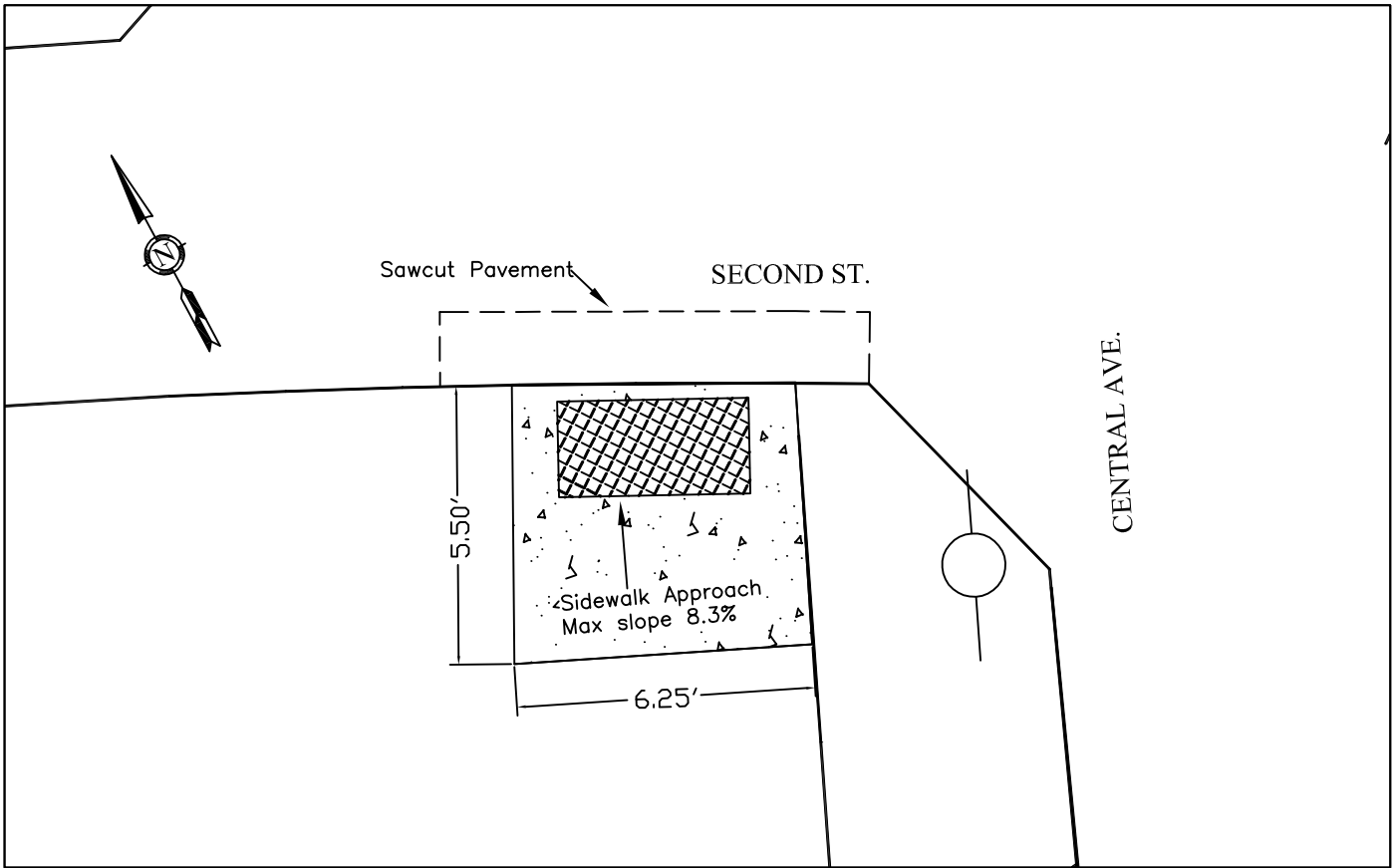

Central Ave. & Second St. (Southeast)

Scale 1":4'

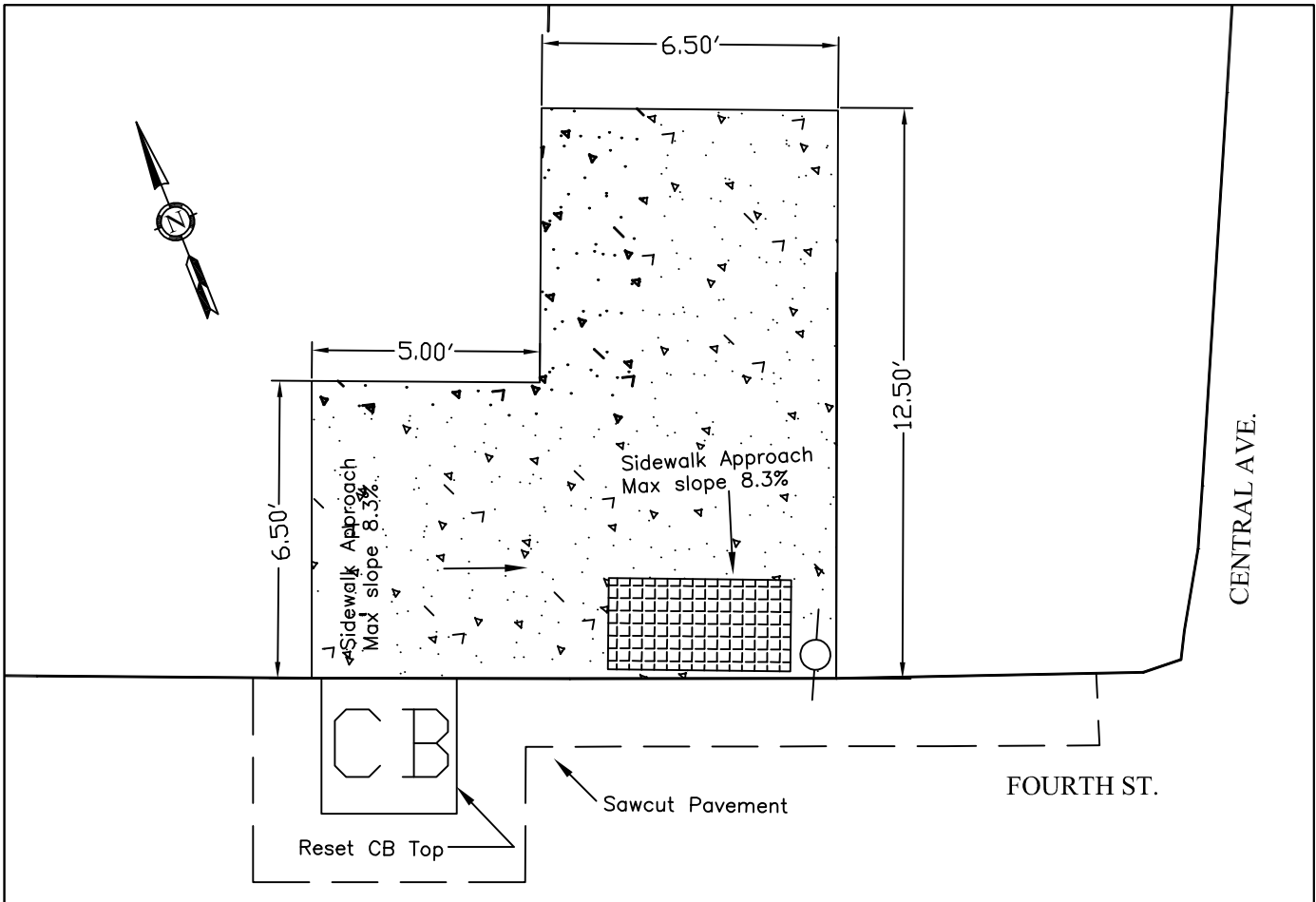

Central Ave. & Fourth St. (Northwest)

Scale 1":4'

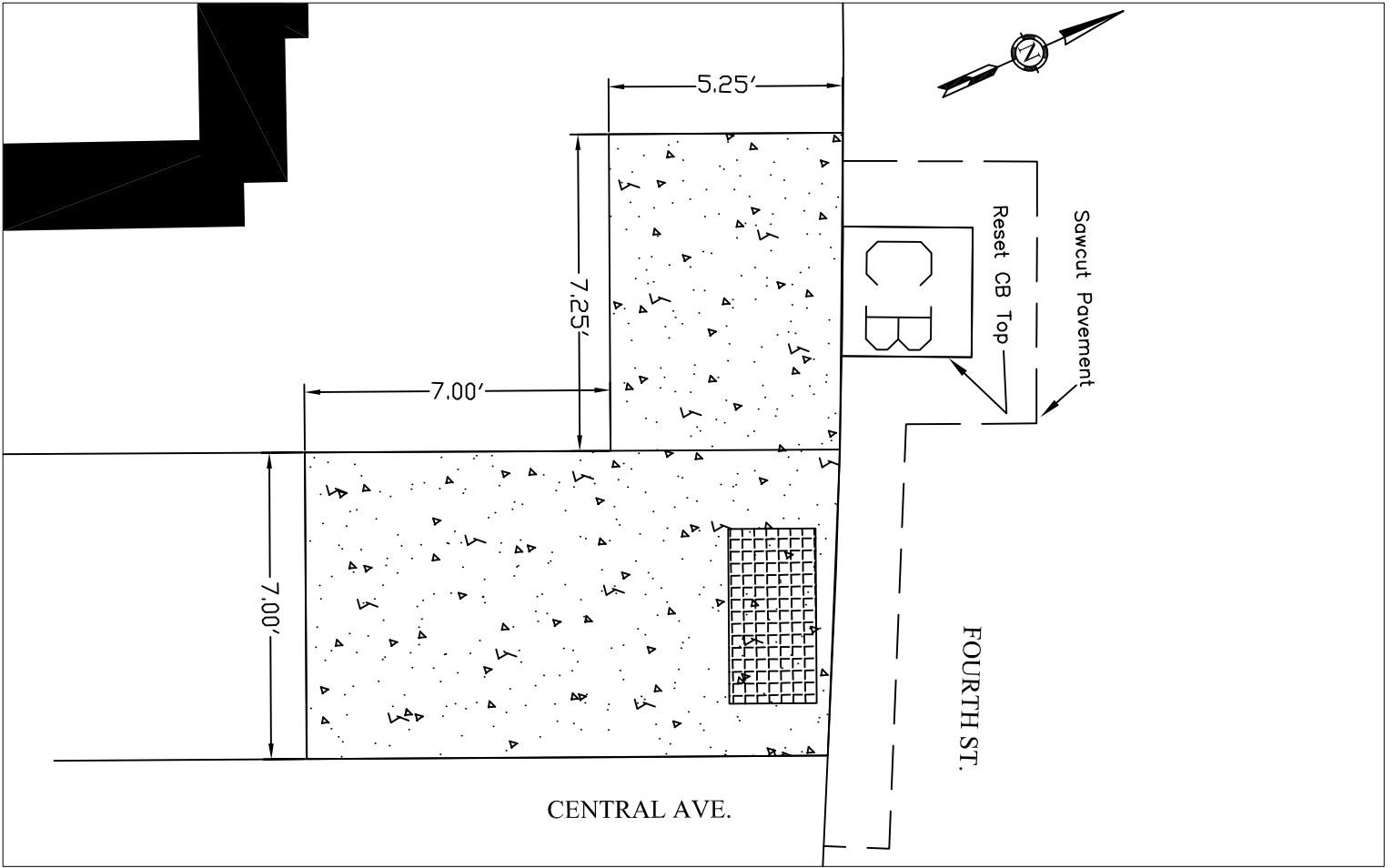

Central Ave. & Fourth St. (Southwest).

Scale 1":4'

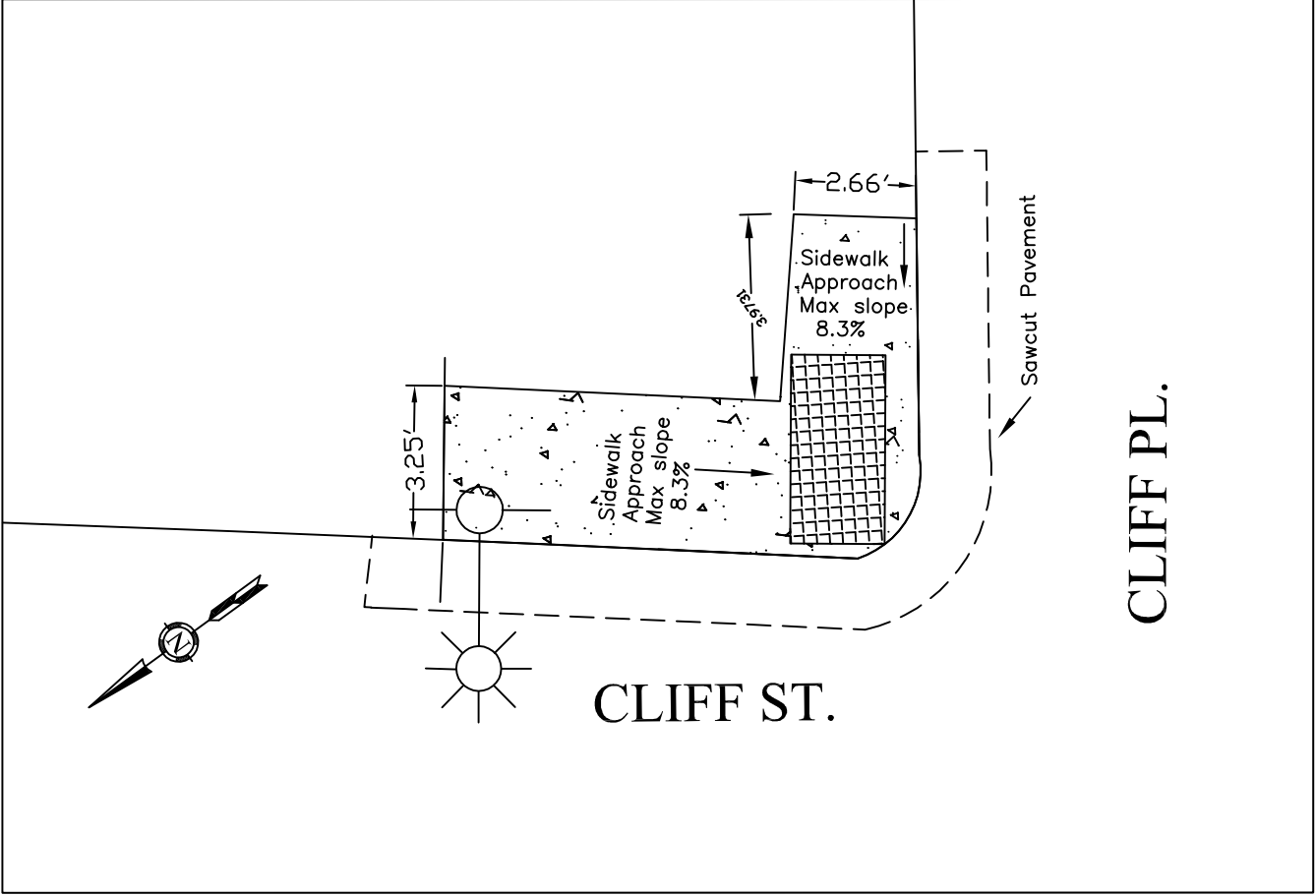

Cliff St. @ Cliff Place (Northeast)

Scale 1":4'



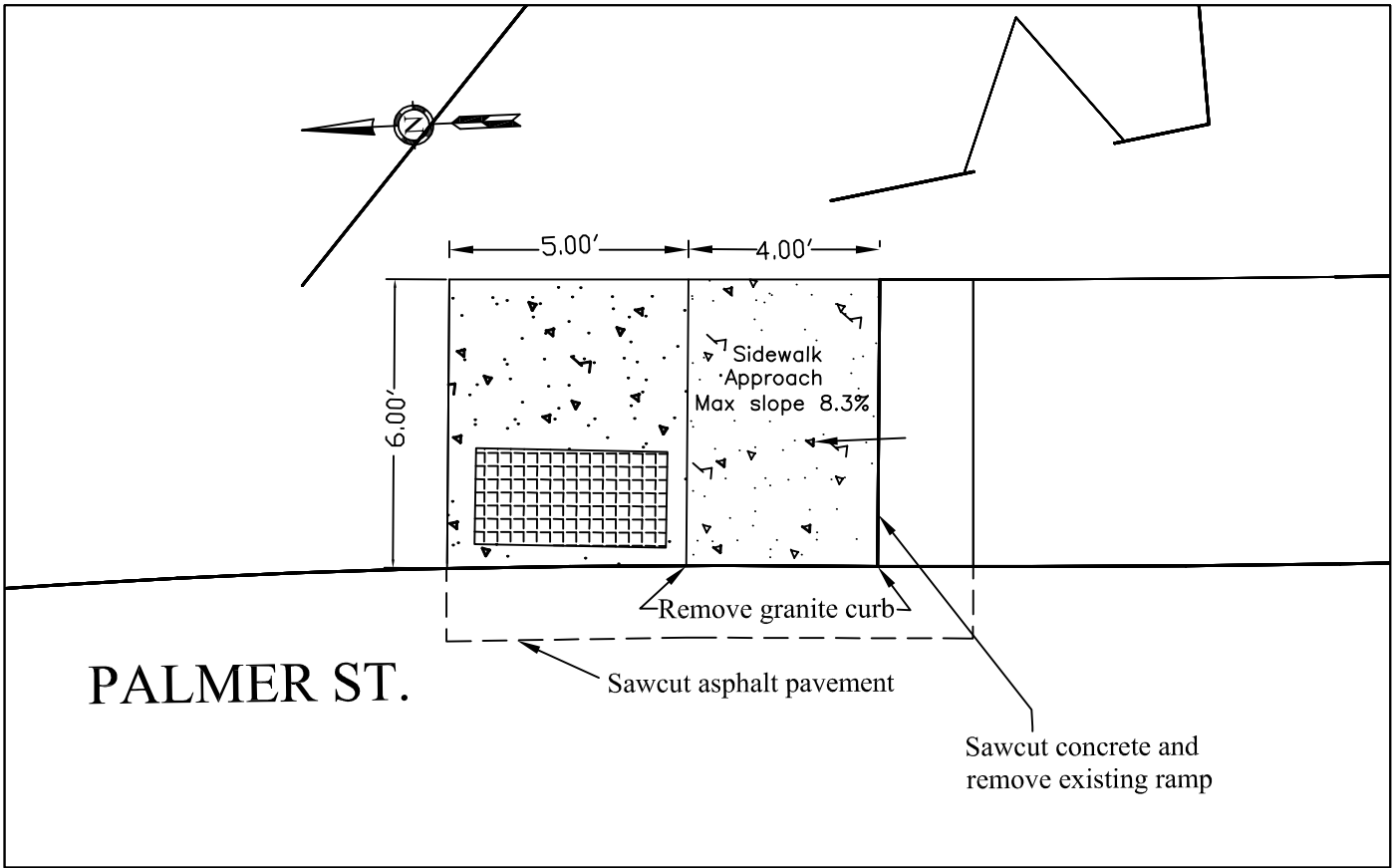

Palmer St. @ East Main St. (Northeast)

Scale 1":4'

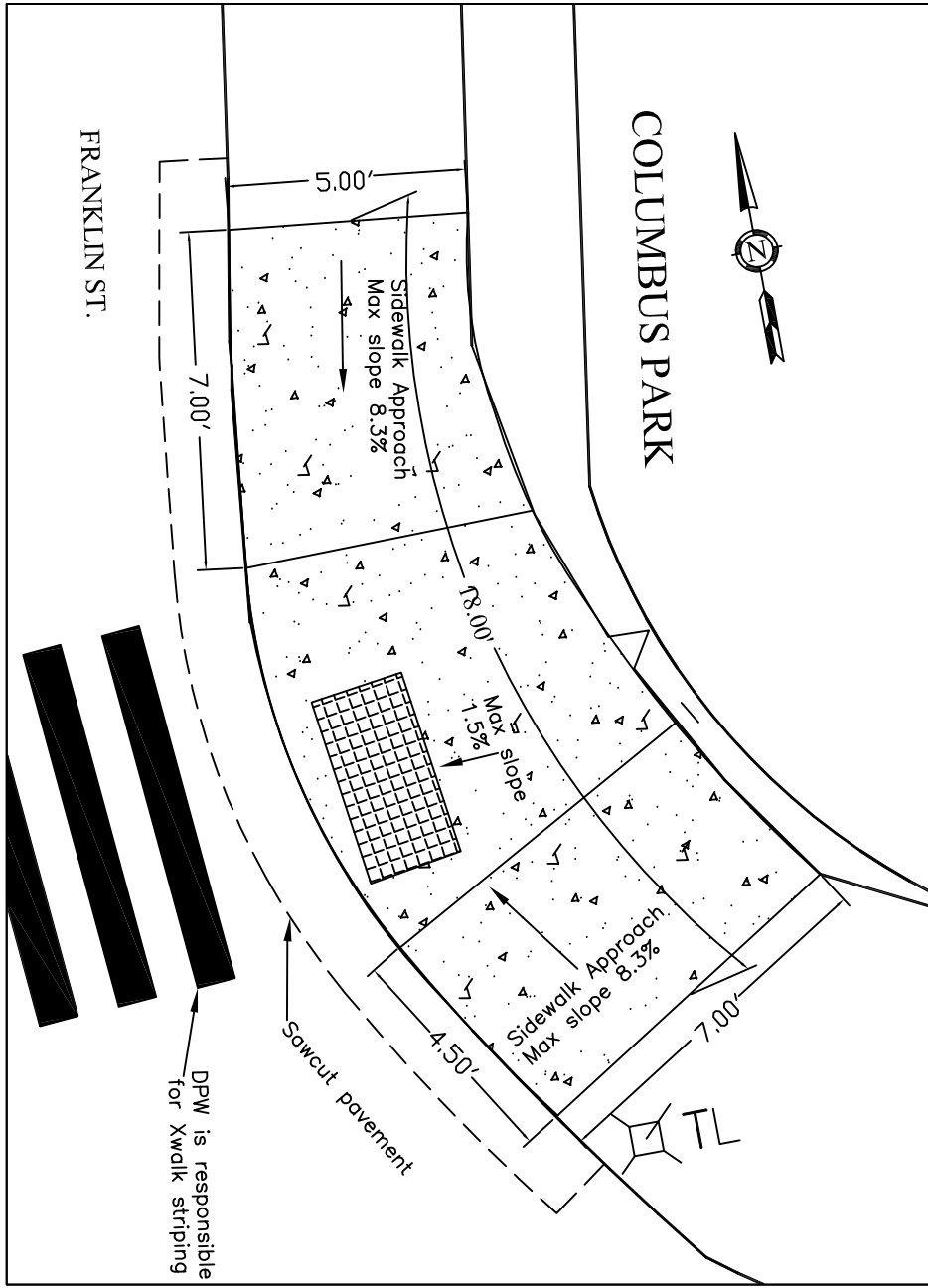

Franklin St.@ Columbus Park - East

Scale 1":4'

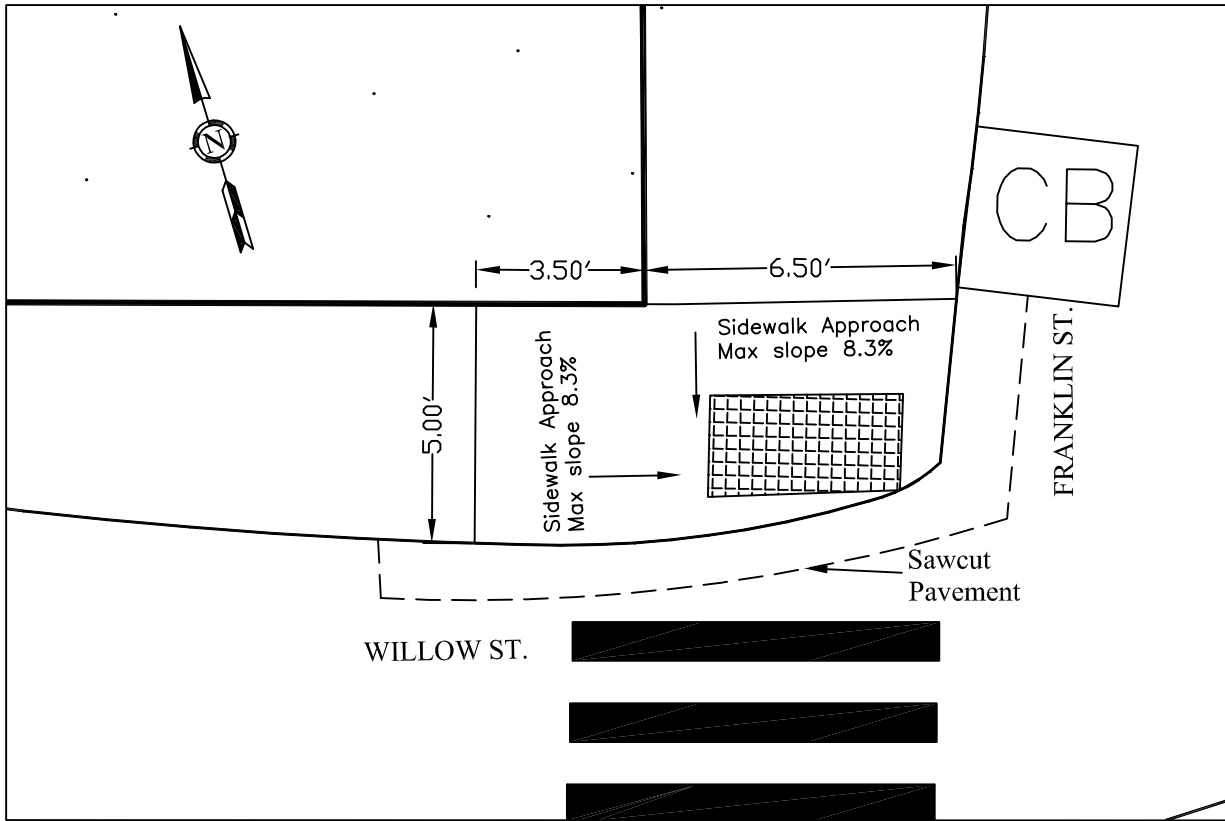

Franklin Street @ Willow (Northwest)

SCALE 1":4'

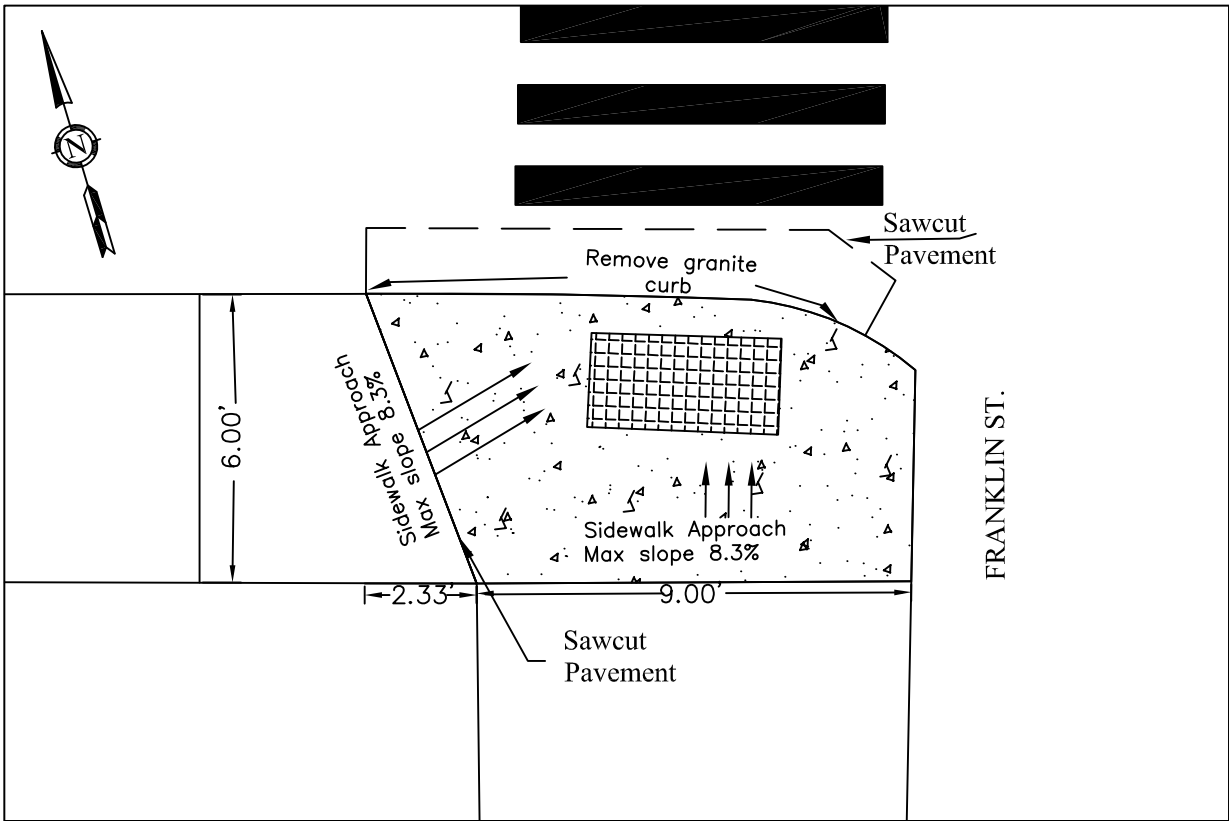

Franklin Street @ Willow (Southwest)

Scale 1":4'

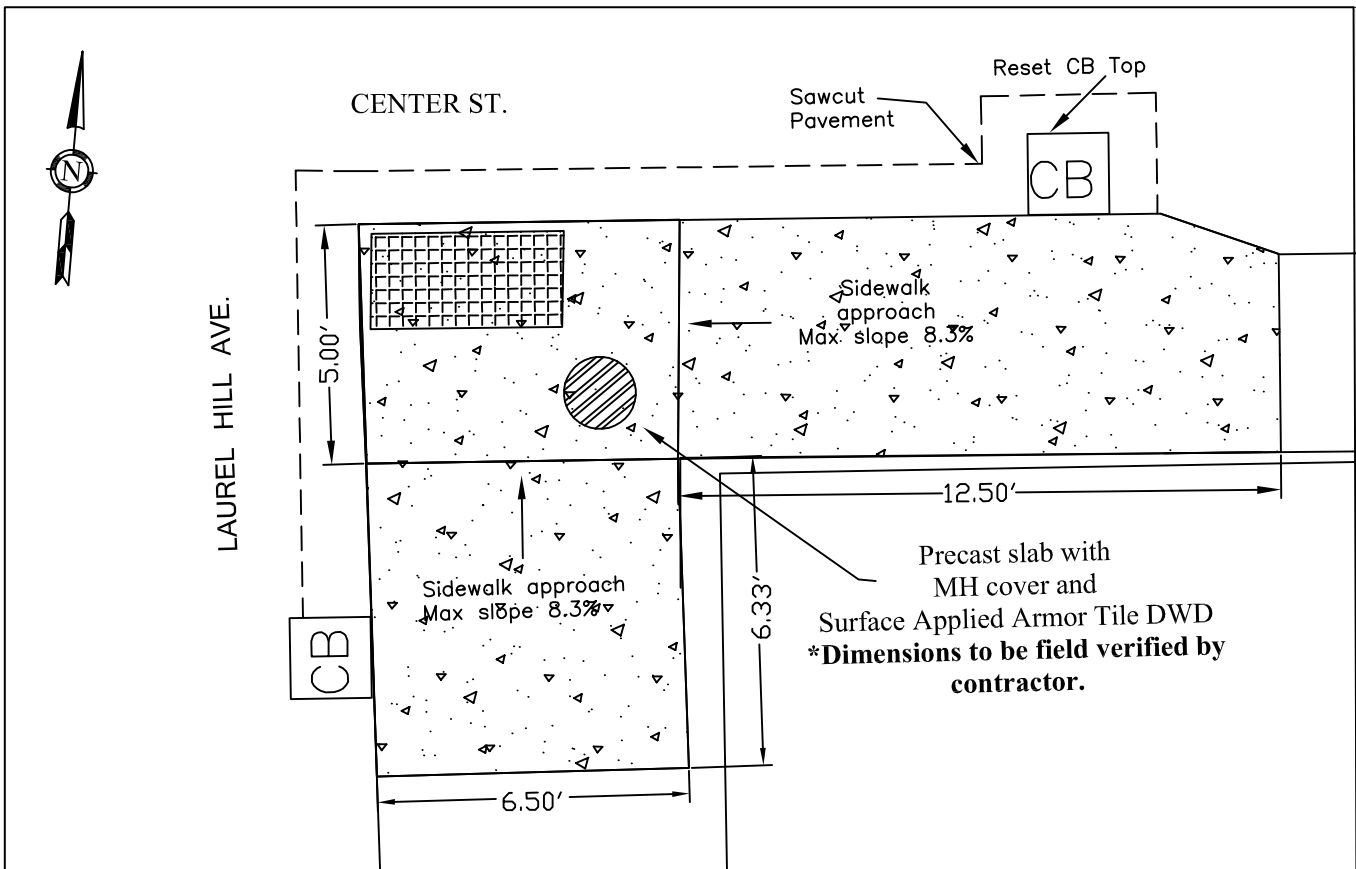

Laurel Hill Ave Route 12 @ Center St (Southeast)

Scale 1":4'

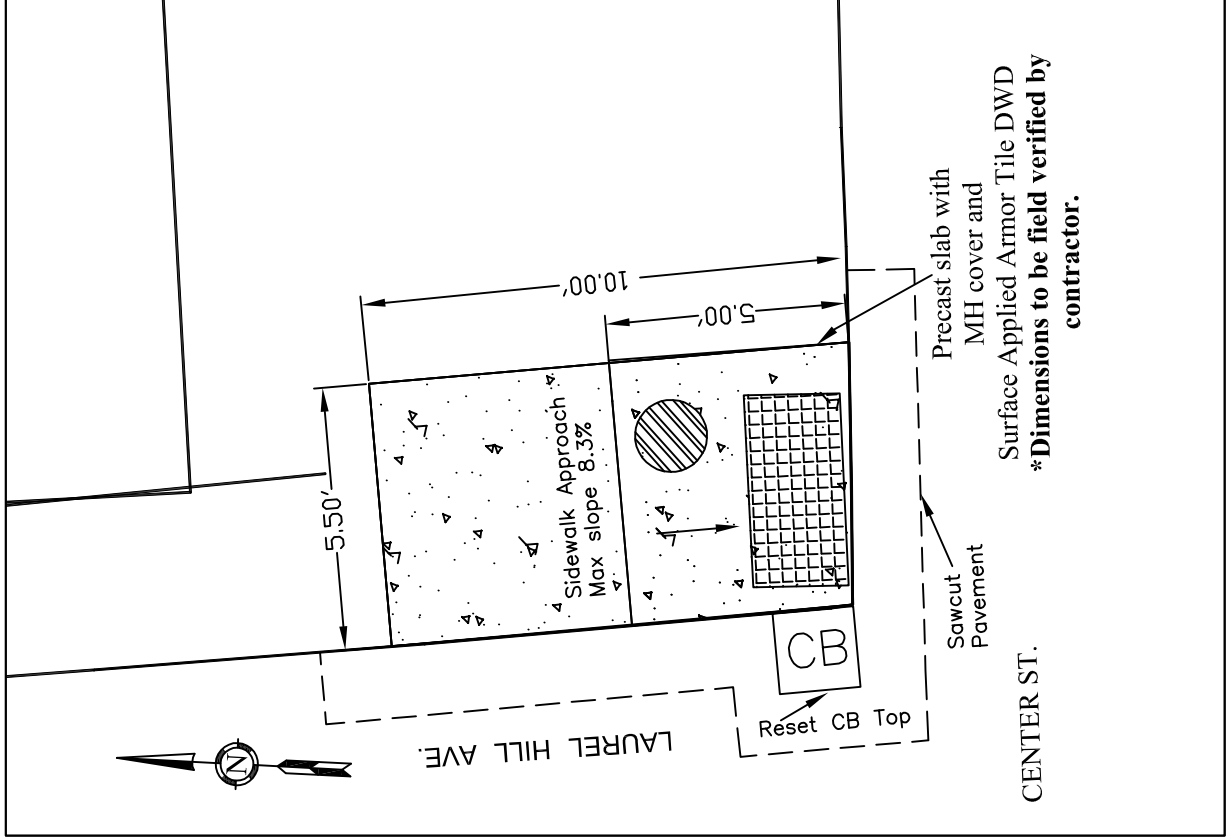

Laurel Hill Avenue (Rte 12) @ Center Street (Northeast)

Scale 1":4'

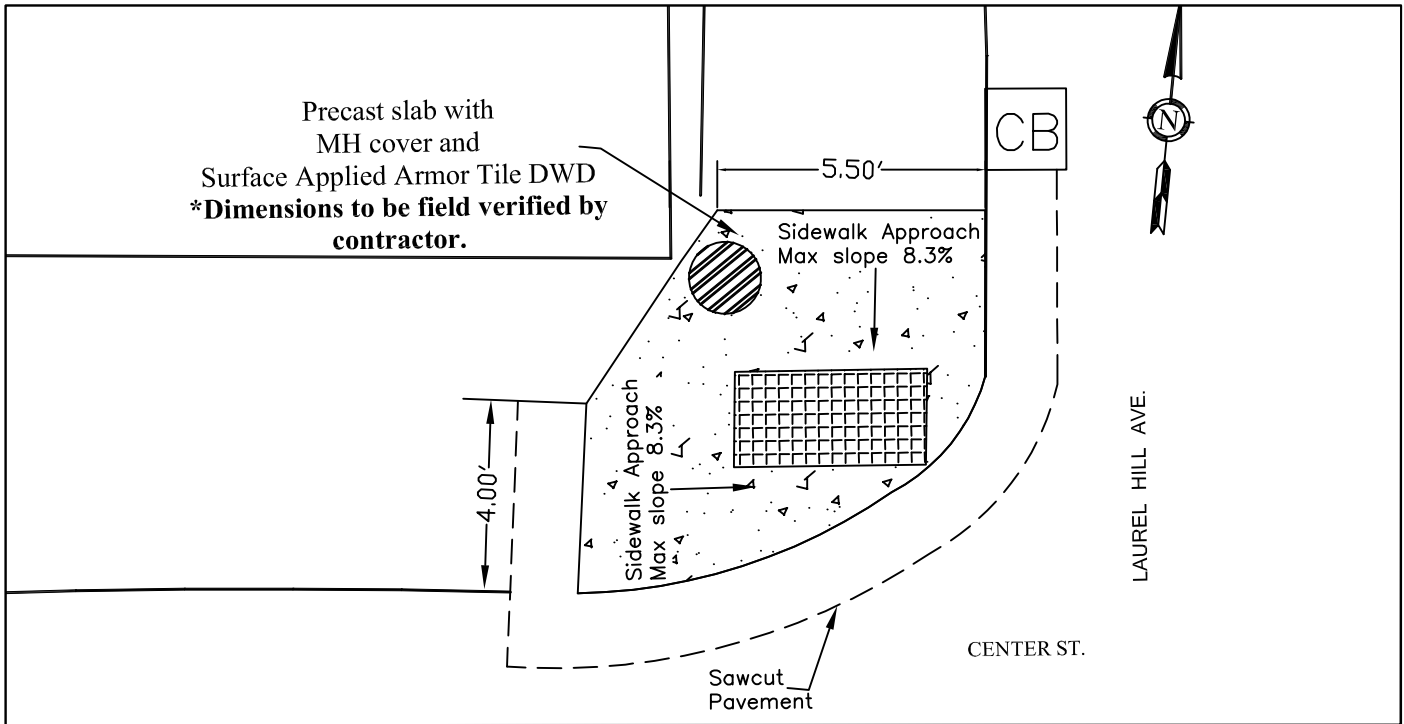

Laurel Hill Avenue (Rte 12) @ Center Street (Northwest)

Scale 1":4'

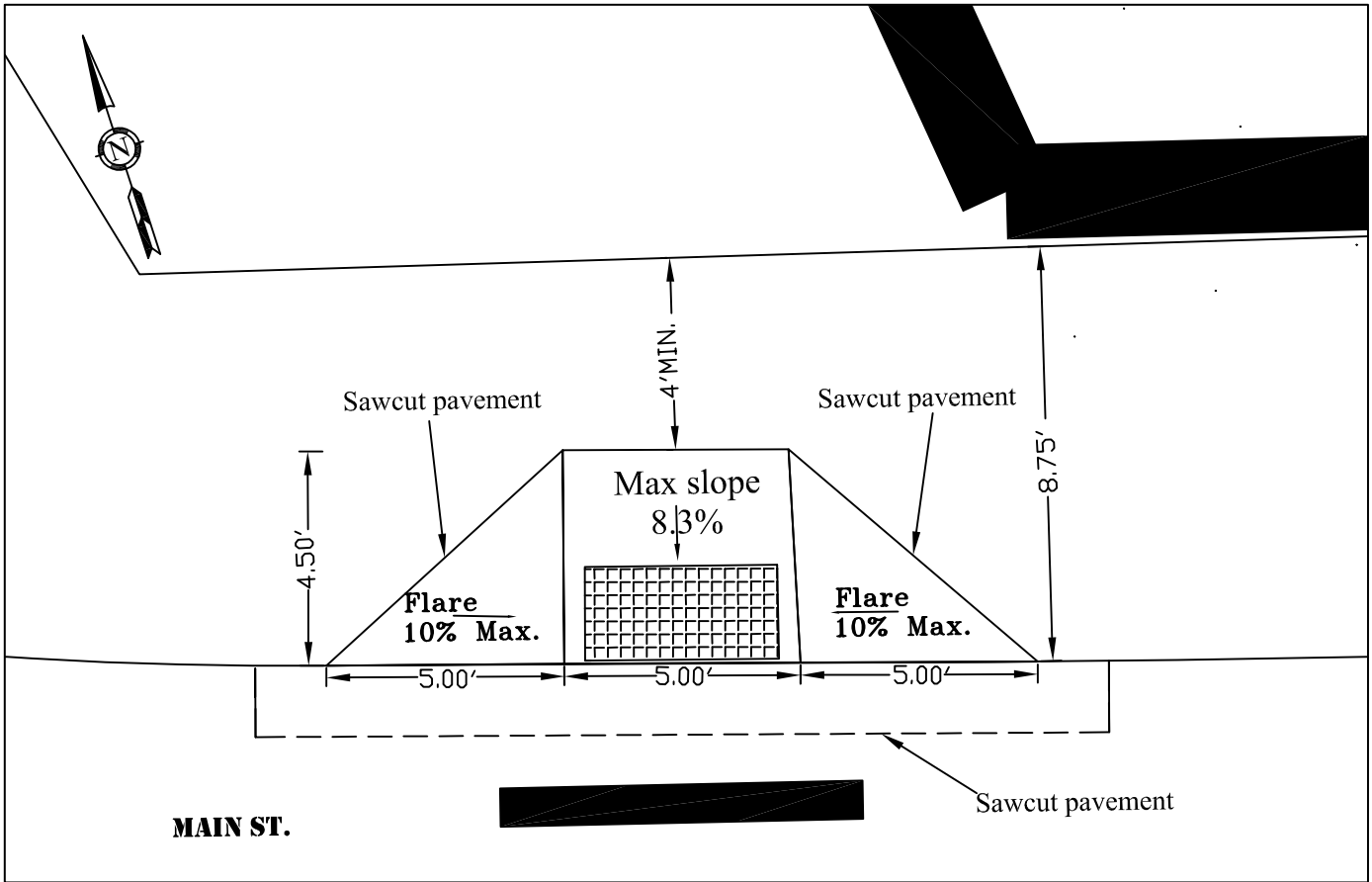

Main St. @ Chelsea Groton Bank

Scale 1":4'



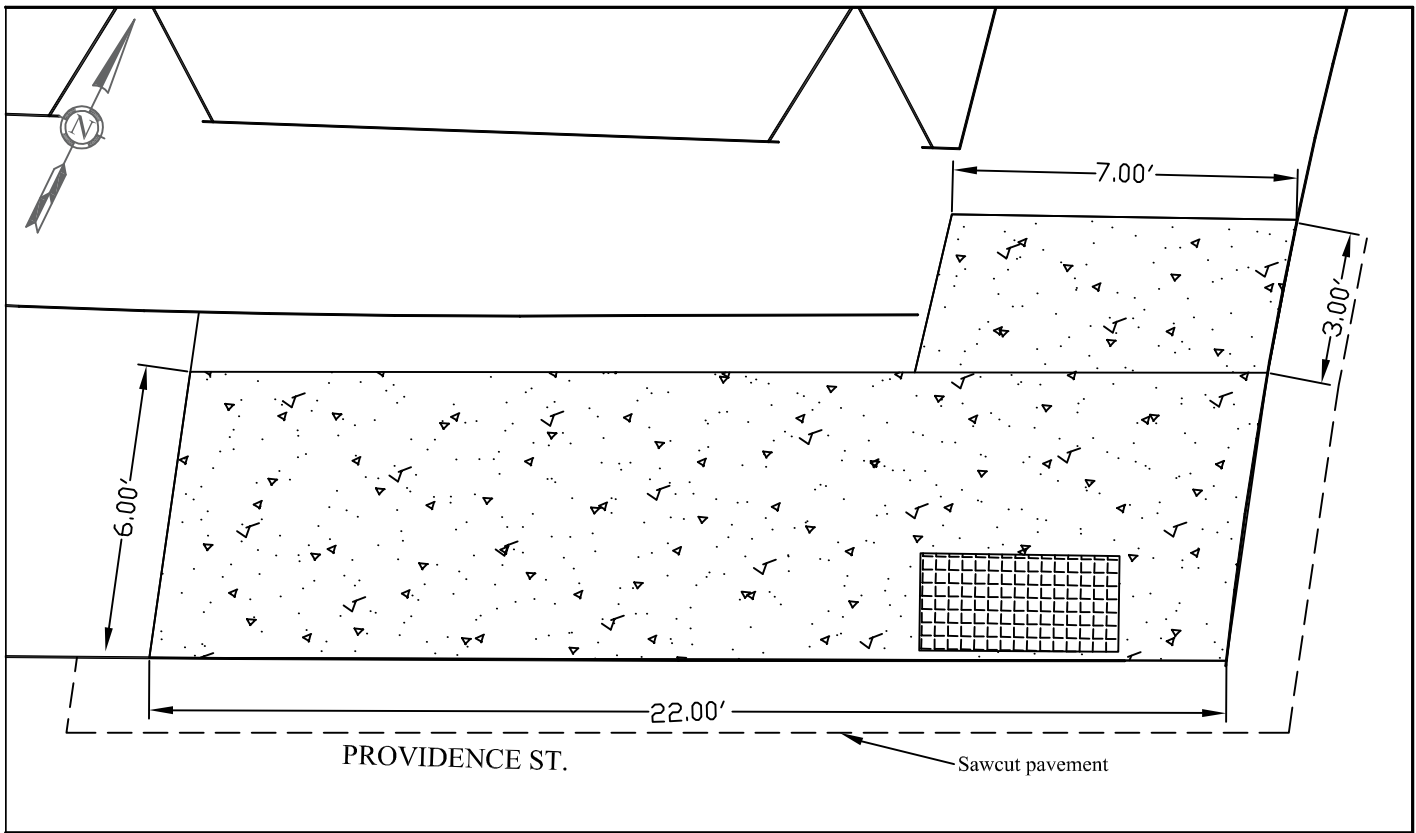

Wequonnoc School at Hunters Ave.

Scale 1":4'

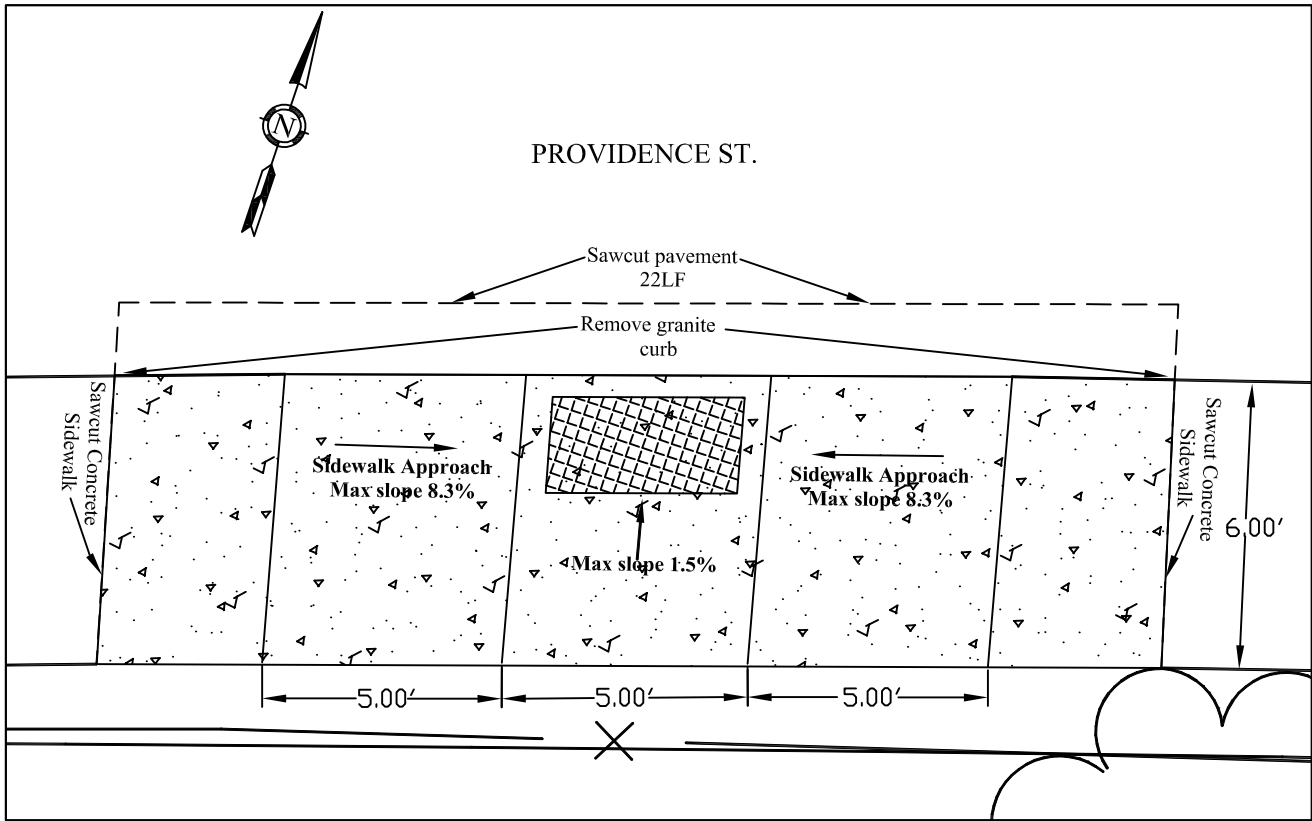

Providence Street @ Wequonnoc (East)

Scale 1":4'

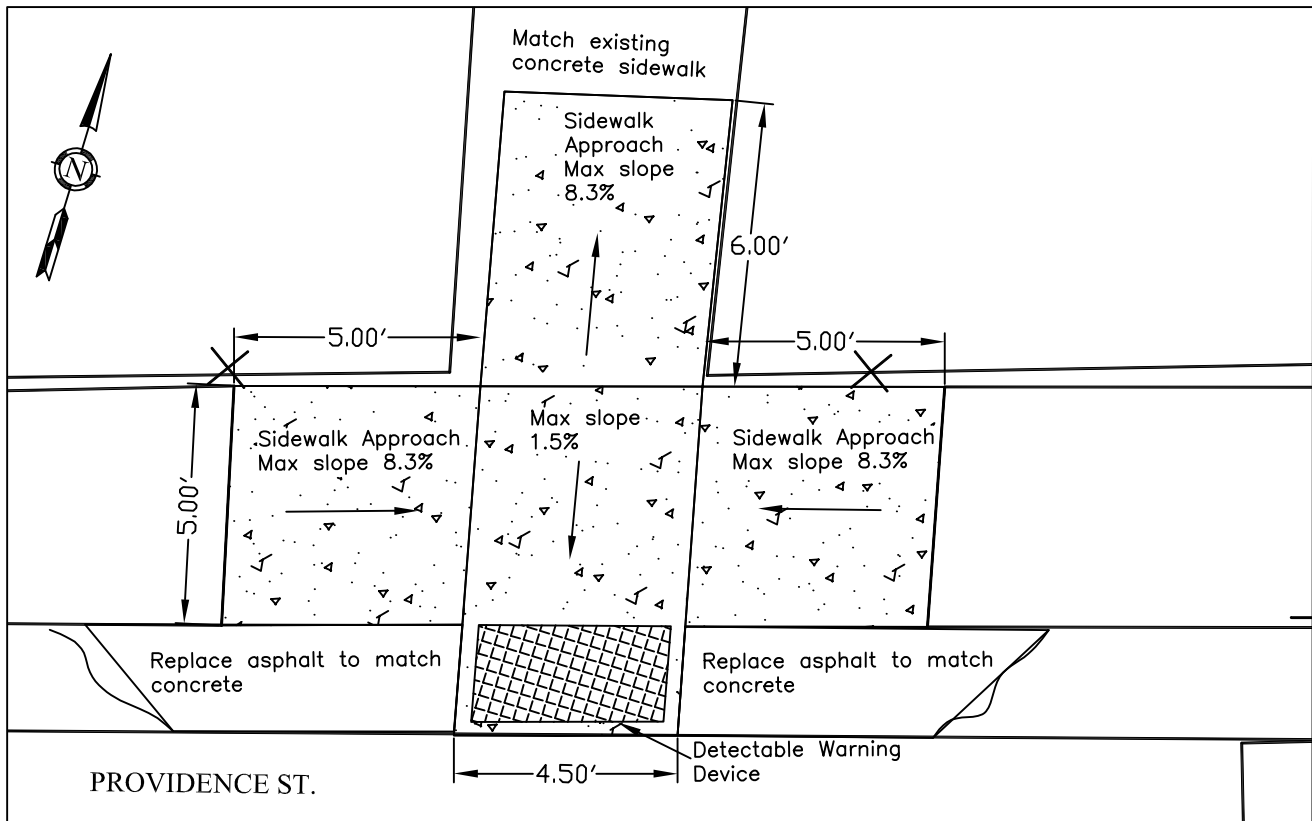

Providence Street @ Wequonnoc (West)

Scale 1":4'

SAWCUT NEAT LINES IN EXISTING ASPHALT ROADWAY TO A 6" DEPTH AND 18" WIDTH  
INSTALL 4" MIN. CLASS 2 ASPHALT PATCH IN 2 LIFTS

EXIST. ROAD SURFACE

18"

DWD ARMOR TILE

5" CONCRETE

SLOPE 1/4" PER FT

MONOLITHIC 12" CONCRETE HAUNCH

8"

8" GRAVEL BASE

CROSS-SECTION

CONCRETE RAMP DETAIL - NTS

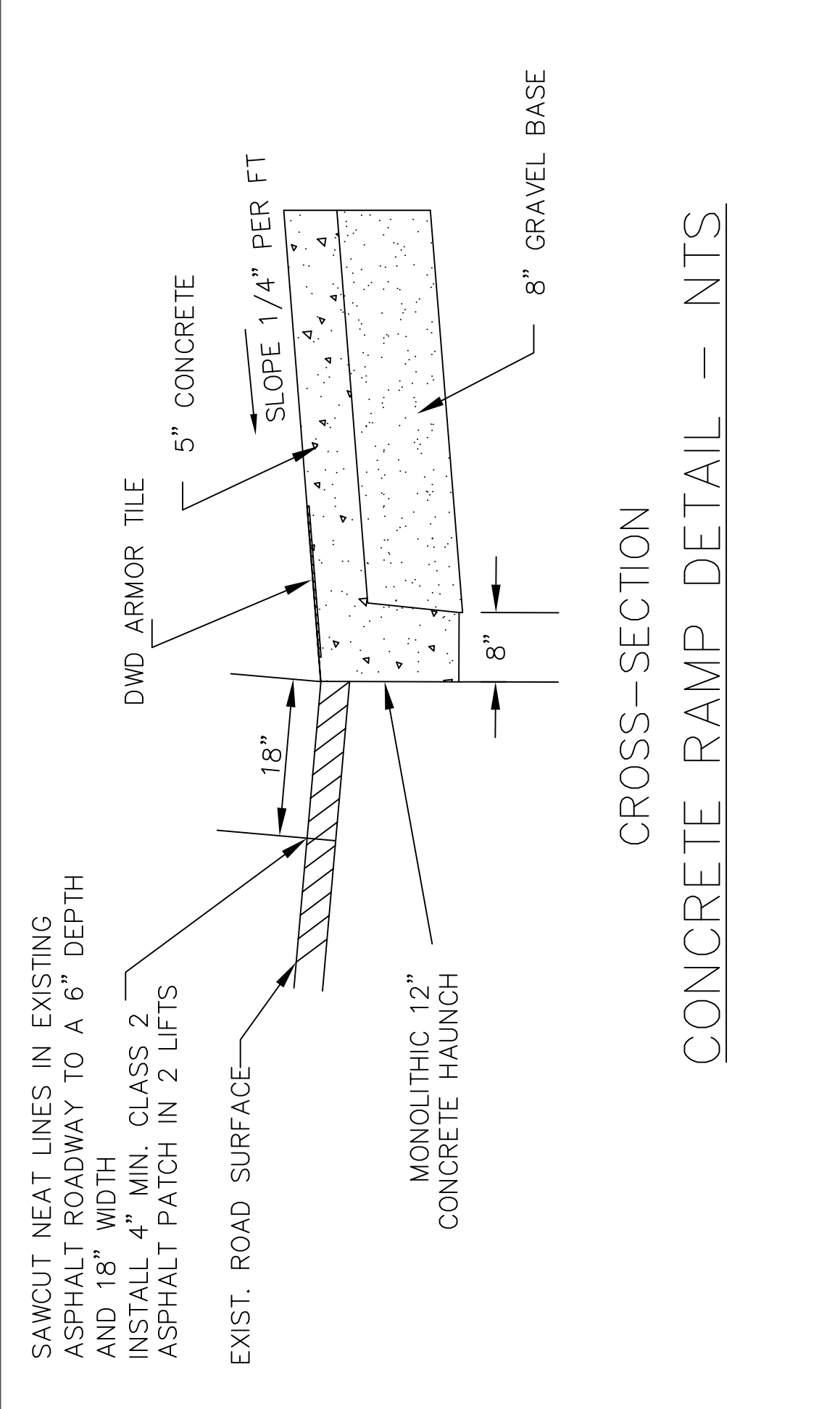

# TYPE "CM" BARRIER CURB CATCH BASIN TOP

DESIGN CONFORMS TO CTDOT  
AND LOCAL SPECIFICATIONS.

## DESIGN NOTES:

1. REINFORCING STEEL DEFORMED BARS CONFORM TO LATEST ASTM SPECIFICATION A615, GRADE 60.
2. CONCRETE COMPRESSIVE STRENGTH— 4,000 PSI AT 28 DAYS SELF COMPACTING CONCRETE MIX.
3. METHOD OF MANUFACTURE: WET CAST.
4. SECTION IS MONOLITHIC.
5. FRAME & GRATE— PAINTED OR GALVANIZED AVAILABLE.
6. GRATE— TYPE A OR B ARE AVAILABLE.

## WEIGHT CHART

PRODUCT	APPROX WEIGHT
TYPE "CM" TOP	1200 LBS

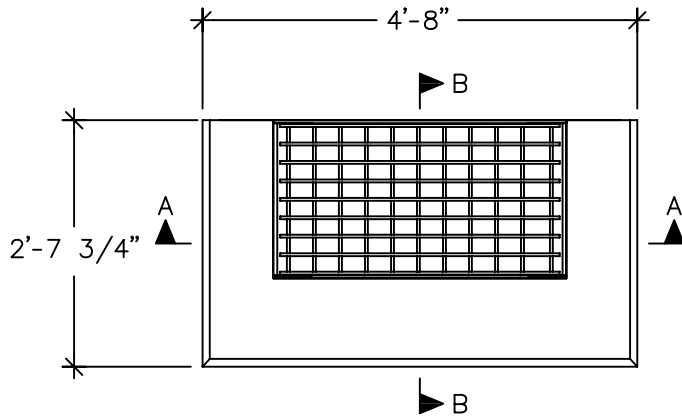

**TOP PLAN VIEW**

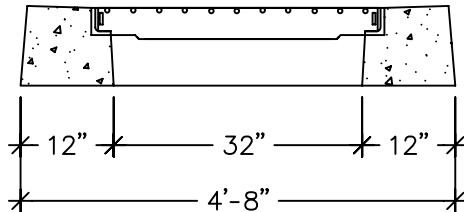

**SECTION A-A**

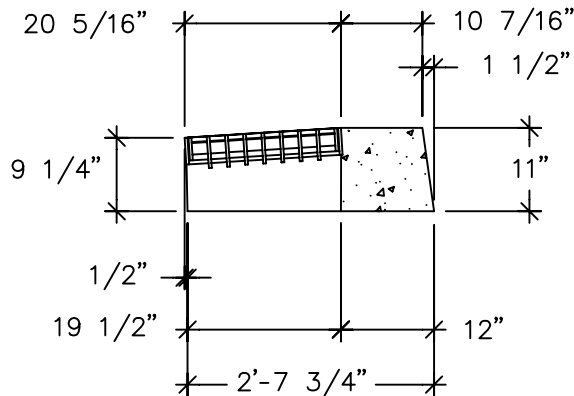

**SECTION B-B**



**UNITED CONCRETE PRODUCTS INC.**

173 CHURCH STREET  
YALESVILLE, CT 06492

TEL. 800 234-3119  
(203) 269-3119

FAX. (203) 265-4941

NOTE:  
ALL DIMENSIONS TO BE FIELD  
VERIFIED BY THE CONTRACTOR

24" MANHOLE FRAME & COVER  
PLACEMENT TO BE VERIFIED BY  
CONTRACTOR

8" CONCRETE - 4000 PSI

#6 DOWEL SLEEVE @ 8" (QTY VARIES)

#4 @ 12" (1 ADD'T BOTH SIDES OF OPG.)

#4 @ 6" (2 ADD'T BOTH SIDES OF OPG.)

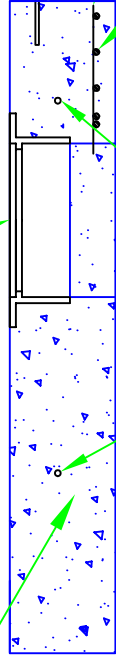

4 EA. LIFT PIN OPENINGS (2 EA SIDE)

CROSS-SECTION

TYP. CONCRETE RAMP WITH MANHOLE DETAIL

N.T.S.

## **BID FORMS**

**CITY OF NORWICH  
NORWICH, CONNECTICUT**

**BID FORM  
Bid No. 7576**

To: City of Norwich  
City Hall  
100 Broadway  
Norwich, CT 06360

From: \_\_\_\_\_  
\_\_\_\_\_  
\_\_\_\_\_  
\_\_\_\_\_

The undersigned, having familiarized (herself, himself, themselves) with the existing conditions on the project sites affecting the cost of the work, and with the contract documents for the **2018 ADA Sidewalk Ramps Project** in Norwich, CT and hereby proposes to furnish all supervision, technical personnel, labor, materials, equipment, tools, appurtenances, services and anything else necessary to perform and complete this project, all in accordance with the contract documents at and for the unit prices for the following work items:

ITEM NO.	DESCRIPTION	UNIT	ESTIMATED QUANTITY	UNIT PRICE	TOTAL PRICE
1.	Maintenance and Protection of Traffic	EA	19		
2.	Concrete Sidewalk and Handicap Ramp	SF	1,646		
3.	Cast in Place Armor-Tile	EA	20		
4.	Surface Applied Armor-Tile	EA	3		
5.	Concrete Sealant	SF	1,759		
6.	Sawcut Bituminous Pavement	LF	420		
7.	Sawcut Concrete Sidewalk	LF	25		
8.	Replace Catch Basin Top	EA	4		
9.	Bituminous Patch	SF	211		
10.	Precast Concrete Slab with Manhole	SF	113		
<b>GRAND TOTAL</b>					

**Grand Total written:** \_\_\_\_\_

The Bidder acknowledges receipt of the following Addenda:

Addendum No. \_\_\_\_\_, dated \_\_\_\_\_

Addendum No. \_\_\_\_\_, dated \_\_\_\_\_

Addendum No. \_\_\_\_\_, dated \_\_\_\_\_

Enclosed is the Bidder's Bond, Bank Check, Cashier's Check or Certified Check No \_\_\_\_\_ in the amount of five percent (5%) of the Bid.



The undersigned accepts the terms, conditions and requirements stated in the Owner's Invitation to Bid and contract documents. The undersigned proposes to all labor, supervision, equipment, tools and incidentals in accordance with the specifications.

The undersigned has carefully checked all the figures on the **Bid Form** and understands that the Owner will not be responsible for any errors or omissions on the part of the undersigned in making up this bid.

Bidder understands that the City of Norwich reserves the right to reject any or all bids, in whole or in part, and to waive any informality in the bidding.

The Bidder agrees that this bid shall be good and may not be withdrawn for a period of ninety (90) days after the scheduled closing time for the receipt of Bids.

Respectfully submitted:

---

Name and Title (in cursive)

---

Name and Title (printed)

(Seal – if bid is by a corporation)

---

Business Address

---

BID BOND

KNOW ALL MEN BY THESE PRESENTS, that we the undersigned, \_\_\_\_\_  
(Name and Address)

\_\_\_\_\_ As PRINCIPAL, and \_\_\_\_\_  
(Name and Address)

\_\_\_\_\_ a corporation duly organized under the laws of the  
State of \_\_\_\_\_ as SURETY are held and firmly bound unto the City of  
Norwich, 100 Broadway, Norwich, CT 06360, hereinafter called the "OWNER", in the sum of \_\_\_\_\_  
Dollars (\$ \_\_\_\_\_) lawful  
money of the United States, for the payment of which sum well and truly to be made, the said  
Principal and Surety, bind ourselves, our heirs, executors, administrators, successors, and  
assigns, jointly and severally, firmly by theses Presents.

THE CONDITION OF THIS OBLIGATION IS SUCH, that whereas the Principal has submitted the  
Accompanying Bid, dated \_\_\_\_\_, 20\_\_\_\_, for \_\_\_\_\_

NOW, THEREFORE, if the Principal shall not withdraw said Bid within the period specified  
therein, after the opening of same, or, if no period be specified, within ninety (90) days after  
the said opening, and shall within such time period as agreed to by the Owner and the  
Contractor, enter into a contract with the Owner in accordance with the Bid, as accepted, and  
give bond with good and sufficient surety or sureties , as may be required, for the faithful  
performance and proper fulfillment of such Contract; or in the event of the withdrawal of said  
Bid within the period specified, or the failure to enter into such Contract and give such bond  
within the time agreed to, the Principal shall pay the Owner the difference between the  
amount specified in said Bid and the Amount for which the Owner may procure the required  
work or supplies or both, if the latter be in excess of the former, then the above obligation shall  
be void and of no effect, otherwise to remain in full force and virtue.

IN WITNESS WHEREOF, the above bounded parties have executed this instrument under their several seals this \_\_\_\_\_ day of \_\_\_\_\_, 20\_\_\_\_\_, the name and corporate seal of each corporate party being hereto affixed and these presents duly signed by the undersigned representative, pursuant to authority of its governing body. In presence of:

_____	_____
(Witness)	(Principal) (Seal)
_____	_____
	(Title)

_____	_____
(Witness)	(Surety) (Seal)
_____	_____
	(Title)

Attorney in Fact, State of \_\_\_\_\_, Power of Attorney for the person signing for the Surety Company must be attached to the Bond.

CERTIFICATE AS TO CORPORATE PRINCIPAL

I, \_\_\_\_\_, certify that I am the \_\_\_\_\_  
Of the Corporation named as Principal within the bond; that \_\_\_\_\_  
Who signed the said bond on behalf of the Principal was then the \_\_\_\_\_  
Of said corporation; that I know his signature, and his signature attached thereto is genuine;  
and that said bond was duly signed, sealed and attested to for and in behalf of said corporation  
by authority of this governing body.

\_\_\_\_\_  
Affix  
Corporate  
Seal

\_\_\_\_\_  
Title

Include this form with your response to the IFB

**NON-COLLUSION AFFIDAVIT**

State of \_\_\_\_\_ )

County of \_\_\_\_\_ )

\_\_\_\_\_, being first duly sworn, deposes and says that:

(Individual's Name)

1. He/she is \_\_\_\_\_ of \_\_\_\_\_  
(Sole Owner, Partner, President, Secretary, etc.) (Corporation Name)

herein after referred to as the "Bidder" that has submitted the attached bid;

2. He/she is fully informed respecting the preparation and content of the attached bid and of all pertinent circumstances respecting such bid;
3. Such bid is genuine and is not a collusive or sham bid;
4. Neither the said Bidder nor any of its officers, partners, owners, agents, representatives, employees or parties in interest, including the affiant, has in any way colluded, conspired, connived or agreed, directly or indirectly with any other Bidder, firm or person to submit a collusive or sham bid, in connection with the contract for which the attached bid has been submitted or to refrain from bidding in connection with such contract, or has in any manner directly or indirectly, sought by agreement or collusion or communications or conference with any other Bidder, firm or person to fix the price or prices in the attached bid or of any Bidder, or to fix any overhead, profit or cost element of the bid price or the bid price of any other Bidder, or to secure through any collusion, conspiracy, connivance or unlawful agreement any advantage against the City of Norwich, CT or any person interested in the proposed contract; and
5. The price or prices quoted in the attached bid are fair and proper and are not tainted by any collusion, conspiracy, connivance or unlawful agreement on the part of the Bidder or any of its agents, representatives, owners, employees, or parties of interest, including this affiant.
6. That no officer or employee or person whose salary is payable in whole or in part from the City of Norwich is directly or indirectly interested in this bid, or in the supplies, materials, equipment, work or labor to which it relates, or in any of the profits thereof.

Signed: \_\_\_\_\_

Title: \_\_\_\_\_

Subscribed and sworn before me this \_\_\_\_\_ day of \_\_\_\_\_, 20\_\_\_\_\_.

\_\_\_\_\_  
Notary Public

My Commission expires on \_\_\_\_\_

NON COLLUSION AFFIDAVIT OF SUBCONTRACTOR

State of \_\_\_\_\_ )  
County of \_\_\_\_\_ ) SS.

\_\_\_\_\_ being first duly sworn ,  
deposes and says that:

- (1) He is \_\_\_\_\_ of \_\_\_\_\_ herein referred to as the "Subcontractor" ;
- (2) He is fully informed respecting the preparation and content of the Subcontractor's Proposal submitted by the Subcontractor to \_\_\_\_\_, the Contractor for certain work in connection with the \_\_\_\_\_ Contract pertaining to the Project in Norwich, Connecticut ;
- (3) Such Subcontractor's Proposal is genuine and is not a collusive or sham Bid;
- (4) Neither the said Subcontractors nor any of its officers, partners, owners, agents, representatives, employees or parties in interest, including this affiant, has in any way colluded, conspired, connived or agreed, directly or indirectly with any other Bidder, firm or person to submit a collusive or sham Bid in connection with the Contract for which the attached Bid has been submitted or to refrain from bidding in connection with such Contract, or has in any manner directly or indirectly, sought by agreement or collusion or communication or conference with any other Bidder, firm or person to fix the price or prices in said Subcontractor's Proposal or to fix any overhead, profit or cost element of the Bid price or the Bid price of any other Bidder, or to secure through any collusion, conspiracy, connivance or unlawful agreement any advantage against the City of Norwich, CT or any person interested in the proposed Contract; and
- (5) The price or prices quoted in the attached Subcontractor's Proposal are fair and proper and are not tainted by any collusion, conspiracy, connivance or unlawful agreement on the part of the Bidder or any of its agents, representatives, owners, employees, or parties of interest, including this affiant.
- (6) That no officer or employee or person whose salary is payable in whole or in part from the City of Norwich is directly or indirectly interested in this Bid, or in the supplies, materials, equipment, work or labor to which it relates, or in any of the profits thereof.

Signed \_\_\_\_\_

Title \_\_\_\_\_

Subscribed and sworn before me this

\_\_\_\_\_ day of \_\_\_\_\_ 20 \_\_\_\_\_

\_\_\_\_\_  
(Notary Public)

My Commission expires \_\_\_\_\_

Statement of Bidder's Qualifications

All items and questions must be answered and the data given must be clear and comprehensive. This statement must be notarized. If necessary, questions may be answered on separate attached sheets. The bidder may submit any additional information it desires.

1. Name of Bidder \_\_\_\_\_
2. Bidder's Tax Identification No. \_\_\_\_\_
3. Permanent main office address \_\_\_\_\_  
\_\_\_\_\_
4. When organized \_\_\_\_\_
5. If corporation, where incorporated \_\_\_\_\_
6. Number of years have you been engaged in the contracting business under your present firm or trade name \_\_\_\_\_
7. Contracts on hand: (Schedule these showing amount of each contract and the appropriate anticipated dates of completion) \_\_\_\_\_  
\_\_\_\_\_
8. General character of work performed by your company \_\_\_\_\_  
\_\_\_\_\_
9. Have you ever failed to complete any work awarded to you? If so, where and why? \_\_\_\_\_  
\_\_\_\_\_
10. Have you ever defaulted on a contract? If so, where and why? \_\_\_\_\_  
\_\_\_\_\_
11. List the more important projects recently completed by your company, stating the approximate cost for each, and the month and year completed (use a separate sheet if necessary) \_\_\_\_\_  
\_\_\_\_\_
12. List your major equipment available for this Contract \_\_\_\_\_  
\_\_\_\_\_
13. List your experience in work similar to this project \_\_\_\_\_  
\_\_\_\_\_

14. List the background and experience of the principal members of your organization, including officers \_\_\_\_\_  
\_\_\_\_\_  
\_\_\_\_\_
15. List the work to be done by Subcontractors and summarize the dollar value of each Subcontract  
\_\_\_\_\_
16. Credit available \$ \_\_\_\_\_
17. Give Bank reference \_\_\_\_\_
18. Will you, upon request, fill out a detailed financial statement and furnish any other information that may be required by the Owner? \_\_\_\_\_  
\_\_\_\_\_
19. The undersigned hereby authorizes and requests any person, firm or corporation to furnish any information requested by the Owner in verification of the recitals comprising this Statement of Bidder's Qualifications.

Dated \_\_\_\_\_ (Name of Bidder)  
By \_\_\_\_\_  
Title \_\_\_\_\_

State of \_\_\_\_\_ )  
County of \_\_\_\_\_ ) ss.

\_\_\_\_\_ being duly sworn deposes and says that (s)he is \_\_\_\_\_  
\_\_\_\_\_ of \_\_\_\_\_

\_\_\_\_\_, and that the answers to the foregoing items and questions and all statements therein contained are true and correct.

Subscribed and sworn to before me this

\_\_\_\_\_ day of \_\_\_\_\_ 20

\_\_\_\_\_  
(Notary Public)

My Commission expires \_\_\_\_\_



(This form must be printed on your firm's letterhead)

## AFFIRMATIVE ACTION/EQUAL OPPORTUNITY EMPLOYMENT POLICY STATEMENT

**XYZ Company** will not discriminate or permit discrimination against any person or group of persons on the basis of race, color, religious creed, age, marital status, national origin, ancestry, sex, gender identity or expression, sexual orientation, intellectual disability, mental disability or physical disability including, but not limited to, blindness, (unless such disability, even with reasonable accommodation, prevents the applicant from being able to perform the work involved), or in any manner prohibited by the laws of the United States or of the State of Connecticut<sup>1</sup>. Further, **XYZ Company** will not retaliate against or condone retaliation against any person or group of persons who oppose actions, treatment or conduct that they believe to be discriminatory.

As an Equal Opportunity Employer, it is the policy and practice of **XYZ Company** to assure that no person will be discriminated against, or be denied the benefit of any activity, program or employment process, in areas including but not limited to recruiting, advertising, hiring, upgrading, promotion, transfer, demotion, lay off, termination, rehiring, employment, rates of pay and/or other compensation or any other terms and conditions of employment on the basis of race, color, religious creed, age, marital status, national origin, ancestry, sex, gender identity or expression, sexual orientation, intellectual disability, mental disability or physical disability including, but not limited to, blindness, unless such disability prevents performance of the work involved.

**XYZ Company** shall take affirmative action to insure that applicants with job-related qualifications are employed and to insure that employees are treated when employed without regard to their race, color, religious creed, age, marital status, national origin, ancestry, sex, gender identity or expression, intellectual disability, mental disability or physical disability, including, but not limited to, blindness, unless it is shown by such contractor that such disability prevents performance of the work involved. If an individual has a disability for which a reasonable accommodation is requested, **XYZ Company** will engage in an interactive process with the individual/representative to determine the individual's needs and accommodation.

(If **XYZ Company** is a union contractor) **XYZ Company** assures that each labor union or representative of its workers has been provided with a copy of this statement and has been informed that **XYZ Company** is an Affirmative Action/Equal Opportunity Employer and has been informed of **XYZ Company's** obligations to comply with state and federal law.

**XYZ Company** also assures that each of its vendors has been informed that **XYZ Company** is an Affirmative Action/Equal Opportunity Employer and of **XYZ Company's** obligations to comply with state and federal law.

**XYZ Company** will implement, monitor and enforce this *Affirmative Action/Equal Opportunity Employment Policy Statement* and program in conjunction with all applicable Federal and State laws, regulations and executive orders. In order to implement our Affirmative Action/Equal Opportunity Employment Program, **XYZ Company** will develop written strategies and plans designated to correct any deficiencies identified. Furthermore, this policy statement, as well as the posters regarding Labor and

Discrimination Laws, shall be posted and otherwise made known to all workers in the company's home office, each satellite office, and at each job site.

Management and supervisory staff will be advised of their responsibilities to ensure the success of this program. Ultimate responsibility for this Affirmative Action/Equal Opportunity Employment Program will be with the (**Insert Head of Company's Name and Official Title**). The day-to-day duties for the plan will be coordinated by (**Insert the name of the company's Affirmative Action/Equal Opportunity Employment Officer**), who is hereby designated the Affirmative Action/Equal Opportunity Employment Officer for **XYZ Company**.

---

<sup>1</sup> If XYZ Company is a firm located in Connecticut and this EEO policy statement is the Company's only EEO policy statement, the company should include all of the covered statuses protected by Connecticut's employment law (e.g.: learning disability and genetic information) to avoid any confusion of employees' protections against discrimination.

I have expressly advised (Insert the name of the company's Affirmative Action/Equal Opportunity Employment Officer) of his/her legal responsibilities as XYZ Company's Affirmative Action/Equal Opportunity Employment Officer pursuant to the Connecticut State Agency Contract Compliance Regulations Section 46a-68j-27(4).

This Affirmative Action Plan has my total support and XYZ Company pledges its best good faith efforts to achieve the objectives of this Affirmative Action Plan. I expect each manager, supervisor and employee of this Company to aid in the implementation of this program and be accountable for complying with the objectives of this Affirmative Action Plan.

---

Date

---

(Signature)

---

Printed Name and Printed Title of Person Signing

CERTIFICATION OF BIDDER REGARDING  
EQUAL EMPLOYMENT OPPORTUNITY

INSTRUCTIONS

This certification is required pursuant to Executive Order 11246 Part II, Section 203(b), (30 FR 12319, 12935). The implementing rules and regulations provide that any bidder or prospective contractor, or any of its proposed subcontractors, shall state whether it has participated in any previous contract or subcontract subject to the equal opportunity clause; and, if so, whether it has filed all compliance reports due under applicable instructions.

Where the certification indicated that the bidder has not filed a compliance report due under applicable instructions, such bidder shall be required to submit a compliance report within seven (7) calendar days after bid opening. No contract shall be awarded unless such report is submitted.

CERTIFICATION BY BIDDER

Bidder's Name \_\_\_\_\_

Address and Zip Code \_\_\_\_\_

1. Bidder has participated in a previous contract or subcontract subject to the Equal Opportunity Clause.  
Yes ( )      No ( ) If answer is yes, identify the most recent contract.
2. Compliance reports were required to be filed in connection with such contract or subcontract  
Yes ( )      No ( ) If answer is yes, identify the most recent contract.
3. Bidder has filed all compliance reports due under applicable instructions, including SF. 100.  
Yes ( )      No ( )      Not Required ( )
4. If answer to Item 3 is "No" please explain in detail on reverse side of this Certification.

Certification - The information above is true and complete to the best of my knowledge and belief. A willfully false statement is punishable by law (U.S. Code, Title 18, Section 1001).

\_\_\_\_\_  
Name and Title of Signer (Please Type)

\_\_\_\_\_  
Signature

\_\_\_\_\_  
Date

CERTIFICATION OF NON-SEGREGATED FACILITIES

This Bidder certifies that he does not maintain or provide his employees any segregated facilities at any of his establishments, and that he does not permit his employees to perform their services at any location, under his control, where segregated facilities are maintained. The Bidder certifies further that he will not maintain or provide for his employees any segregated facilities at any of his establishments, and that he will not permit his employees to perform their services at any locations, under his control, where segregated facilities are maintained. The Bidder agrees that a breach of his certification will be a violation of the Equal Opportunity clause and any Contract resulting from acceptance of this Bid. As used in this certification, the term "segregated facilities" means any waiting rooms, work areas, restrooms and washrooms, restaurants and other eating areas, timeclocks, locker rooms and other storage or dressing areas, parking lots, drinking fountains, recreation or entertainment areas, transportation, and housing facilities provided for employees which are segregated by explicit directive or are, in fact, segregated on the basis of race, color, religion or national origin, because of habit, local custom or otherwise. The Bidder agrees that (except where he has obtained identical certification from proposed Subcontractors for specific time periods) he will obtain identical certifications from proposed Subcontractors prior to the award of Subcontracts exceeding \$10,000 which are not exempt from the provisions of the Equal Opportunity clause; that he will retain such certifications in his files; and that he will forward the following notice to such proposed subcontractors (except where the proposed subcontractors have already submitted identical certifications for the specific time periods):

"Notice to prospective subcontractors of requirements for non-segregated facilities. A certification of non-segregated facilities must be submitted prior to the award of a subcontract exceeding the Equal Opportunity Clause. The certification may be submitted either for each subcontract or for all subcontracts during a period (i.e. quarterly, semi-annually, or annually).

Note: The penalty for making false statements in offers is prescribed in 18 U.S.C. Paragraph 1001.

Date: \_\_\_\_\_

By: \_\_\_\_\_

Official Address: \_\_\_\_\_

Title: \_\_\_\_\_

\_\_\_\_\_