

Town of Simsbury

933 HOPMEADOW STREET

SIMSBURY, CONNECTICUT 06070

ADDENDUM #1 October 18, 2018

Project No. 18-05 Simsbury Public Library - Lower Level Improvements

NOTE: THIS ADDENDUM CONTAINS IMPORTANT INFORMATION REGARDING CHANGES OR CLARIFICATIONS TO THE REQUIREMENTS OF THE CONTRACT DOCUMENTS. SUCH MODIFICATIONS ARE TO BE INCORPORATED INTO THE CONSTRUCTION DOCUMENTS AND SHALL APPLY TO THE WORK WITH THE SAME MEANING AND FORCE AS IF THEY HAD BEEN INCLUDED IN THE ORIGINAL DOCUMENT. WHEREVER THIS ADDENDUM MODIFIES A PORTION OF A PARAGRAPH OF THE PROJECT MANUAL OR A PORTION OF ANY DRAWING, THE REMAINDER OF THE PARAGRAPH OR DRAWING SHALL REMAIN IN FORCE.

Replacement or additional pages are attached. Please acknowledge receipt of addenda in the submitted Bid.

CLARIFICATIONS TO THE SPECIFICATIONS:

1. **Section 2 - Instructions to Bidders**

Revise Section 39 to include: "The full set of wage rates should be included in Section 3 including all attachments at the following link.

"Be sure to click on the link below to obtain the necessary documents to include in the bid packet. "
<http://www.ctdol.state.ct.us/wgwkstnd/BidPack.htm>]"

2. **Section 2 - Instructions to Bidders**

Add: "Connecticut State Library – State Library Construction Grant Contract for Municipalities" as referenced in Paragraph 38 State Grant Funding Terms and Conditions, attached.

3. **Section 2 - Instructions to Bidders**

Add: "Connecticut Department of Labor Wage and Workplace Standards Division" as referenced in Paragraph 39 Prevailing Wage Rates, attached.

4. **Section 4.2 – Performance Bond**

Replace document with attached Performance Bond document.

5. **06.20.23 Finish Carpentry**

Revise Section 2.1, Paragraph A, Item 2 to read: "Merillat Classic Series with maple "Marlin" style door, drawer and finished end panel design. Layout as per drawings.

Telephone (860) 658-3260
Facsimile (860) 658-3205

www.simsbury-ct.gov

An Equal Opportunity Employer
8:30 – 7:00 Monday
8:30 - 4:30 Tuesday through
Thursday
8:30 – 1:00 Friday

6. **09.30.00 Tile**

Revise Section 2.2 Paragraph A, Item 1b to read: "Wall Tile – 12x12."

CLARIFICATIONS TO THE DRAWINGS:

7. **AR100 Lower Floor Plan – Demolition + Removals**

Revise new masonry opening at north wall of Meeting Room 033, see attached Sketch AR-100.1.

8. **AR100 Lower Floor Plan – Demolition + Removals**

Revise Specific Note 14 to read: ".....Existing water closet and lavatory to be removed and replaced with new fixtures."

9. **A100 Lower Floor Plan – New Work + Notes**

Add General Note "10) All new partitions to be installed to underside of existing deck."

10. **A100 Lower Floor Plan – New Work + Notes**

Add General Note "11) All wall furring at existing exterior concrete foundation walls to receive batt insulation for continuous insulation plane."

11. **A100 Lower Floor Plan – New Work + Notes**

At Door #046 add note: "Provide Raydoor double sliding panel symmetrical S2S WM XRDLP with wood veneer frame, opal insert, ADA pull and ADA thumb turn, and flush bolt."

12. **A100 Lower Floor Plan – New Work + Notes**

Revise Wall Tag "1" at West wall of Booksale Storage to read "3."

13. **A100 Lower Floor Plan – New Work + Notes**

Revise Note at West wall of Booksale Storage Room to read: "Provide and install new galvanized steel areaway by Admiral Steel or equal, Economy Straight ES-5918 24" height with steel grate cover."

14. **A100 Lower Floor Plan – New Work + Notes**

Revise Specific Note 10 to read: "Provide new wall mounted water closet, American Standard "Flowise" model 2257.001, accessible wall hung with manual flush valve Sloan model 111-1.28. Elongated seat, Church model 295CT open front seat. Provide new wall mounted lavatory, American Standard "Lucerne" model 0355.012 with 4" centers and overflow. Faucet American Standard "Reliant 3" model 7385.053., single control, 4" centers, grid drain and extra-long handle. Provide thermostatic mixing valve Symmons model 7-225 and Truebro lav guard for all exposed piping. All Plumbing fixtures shall be furnished with new supply piping, trap, escutcheon plates, and shut-off valves for a complete installation."

15. **A100 Lower Floor Plan – New Work + Notes**

2/A100 Replace "Elevation" for 2/A100 with SK-A100.1.

16. **A100 Lower Floor Plan – New Work + Notes**

2/A100 Add "Section AA" and "Section BB" on SK-A100.2.

17. **A101 Lower Floor Reflected Ceiling Plan – New Work**

Add to Specific Note 3: ".....Coordinate final location with Owner's Project Rep and Owner's Technology Consultant.

18. **A101 Lower Floor Reflected Ceiling Plan – New Work**

Add to Specific Note 4: ".....Coordinate final location with Owner's Project Rep and Owner's Technology Consultant.

19. **A101 Lower Floor Reflected Ceiling Plan – New Work**
Add Notes 3 and 4 to Meeting Room 033.
20. **A400 Finish Schedule, Wall Types + Rest Room Elevations**
1/A400 Revise "Scale....." to read "Scale: 3/8" = 1'-0"."
21. **A401 Door Schedule, Types + Details**
Door Schedule Door #048: Replace Door Width "2(3'-0)" to read "3'-8"," and replace Frame Width "6'-4"" to read "4'-0"."
22. **A401 Door Schedule, Types + Details**
Door Schedule Door #045 and #053: Replace Frame Width "6'-4"" to read "3'-4"."
23. **A402 Details**
Replace Detail 10/A402 with Sketch A402 attached.
24. **MD100 Mechanical Lower Floor Plan – Demo & New Piping Work**
Replace sheet MD100 with attached sheet MD100, issued for Addendum #1: 17 OCT 2018.
25. **M100 Mechanical Lower Floor Plan – New**
Replace sheet M100 with attached sheet M100, issued for Addendum #1: 17 OCT 2018.
26. **ED100 Electrical Lower Floor Plan – Demo**
Replace sheet ED100 with attached sheet ED100, issued for Addendum #1: 17 OCT 2018.
27. **EL100 Electrical Lighting Lower Floor Plan**
Replace sheet EL100 with attached sheet EL100, issued for Addendum #1: 17 OCT 2018.
28. **EP100 Electrical Power Lower Floor Plan**
Replace sheet EP100 with attached sheet EP100, issued for Addendum #1: 17 OCT 2018.
29. **EP100 Electrical Power Lower Floor Plan**
Provide (2) two above counter wall receptacles for power and data at east wall of Meeting Room 033 on 6, L3-1.
30. **Town Service Providers for Contractor Coordination**

Mechanical Systems Controls – Eric Beach at UCS United Control Solutions Inc (860.993.7362)
Fire Alarm System - Mike Clapis at Clapis Associates Inc (860.416.6003)
Sprinkler System – Hartford Sprinkler Company (860.231.0088)
31. **See attached Pre-Bid Meeting Minutes, Attendance Sheet, Documents and Drawings.**
32. **See attached RFIs and responses.**

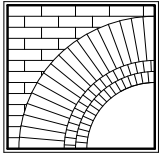

**BUTLER
ROWLAND
MAYS**

**ARCHITECTS,
LLP**

Pre-Bid Meeting

PROJECT: Lower Level Improvements for the:
Simsbury Public Library

TOWN PROJECT N°: 18-05
ARCHITECT PROJECT N°: 16•39•28

DATE: 10 October 2018

ATTENDING: Meghan Brennen, Butler Rowland Mays Architects, LLP
Jim Russo, JR Russo, LLC – Owner’s Project Representative
Jeff Shea, Town Engineer, Town of Simsbury
Tom Roy, Head of Public Works, Town of Simsbury
Lisa Karim, Library Director, Town of Simsbury
See Attached “Sign-In Sheet” for Contractors

TOPIC	RESPONSE / ACTION REQUIRED
Introduction	Introduction of Town all Officials, Library Director, and Owner’s Project Representative.
Mandatory	This meeting is mandatory and only firms in attendance bid proposals will be recognized.
Summary	Contract scope summary: Interior fit-up of existing unfinished space for new Meeting Room and Booksale Storage Room including, but not limited to, new flooring, interior partitions and doors, ceilings, lighting and mechanical improvements; new Gallery connection to existing Lobby; fit-up of new Conference Room in existing Storage Room area; as well as finish and fixture updates to an existing individual Rest Room. Improvements to the existing fire protection system are also included.
Wage Rates	State of Connecticut Dept of Labor Prevailing wage rates apply. Contractors must submit certified payroll documentation with each payment application for processing. Payment applications will not be approved without certified payroll.
Tax Exempt	The Town is a tax-exempt entity; a tax-exempt certificate is to be provided to successful bidder.
Permit Fees	The Town of Simsbury permit fee will be waived, however the State Education fee of \$0.26 per thousand dollars of construction will be the Contractor’s responsibility.
Site Conditions	<p>The Library will remain open throughout the project; the public and staff will occupy the building daily. The Contractor will utilize the existing exterior doors for all project access. Contractor work in public areas should be limited to avoid interference and disruption to Library activities. Work in the Lobby, Rest Room and other public areas should be scheduled in advance with the Owner’s Project Representative.</p> <p>Work is to be performed during normal daytime hours, any disruptive work scheduled for public areas of the building should be implemented before the Library opens at 9:30am. Temporary protection measures must be used for work in public areas, or areas adjacent to finish spaces. All public areas must be cleaned and left in usable condition for Staff and Patron occupancy each day. Contractor shall exercise dust minimization protection and procedures throughout work.</p> <p>All existing wall, floor and ceiling finishes altered or damaged during installations must be repaired to match surrounding finishes, including gwb repair and repainting.</p> <p>Contractor layout area will be provided on the front lawn of the building as indicated in the Contractor Layout Graphic in the bid documents. Three on-site parking spaces will be reserved for Contractor use, additional parking will be provided at the adjacent property – Boy Scout Hall. Contractor will be responsible for snow removals in the layout area and for any</p>

Security	<p>additional required access to the area(s) of work. At the completion of the project, the Contractor will be responsible for aerating, seeding and haying the Layout Area, and removing the tree protection.</p> <p>Turning off power and heat for any duration of time must be coordinated with the Library Director and staff at least 24 hours in advance, and temporary heat and lighting should be provided.</p> <p>Contractor will be responsible for coordinating with fire alarm company.</p> <p>Contractor shall coordinate with Owner on installation of an emergency generator being completed as a separate and concurrent project by the Owner.</p>
Town Property	<p>Before any field employee or staff is allowed on site, a background check must be completed by the Town. A background check form is provided in the Information Available to Bidders.</p> <p>The Library is Town property therefore smoking, alcohol, and/or drug usage is strictly prohibited, any identified abuse will result in the individual being barred from all Town sites.</p>
Schedule	<p>Bids due at Town of Simsbury's Finance Director's Office (933 Hopmeadow Street, Simsbury) – Wednesday –24 October 2018 before 3:00 PM; Bids will be opened publicly & read aloud after 3:00 on the same date.</p> <p>The Town will issue a Notice of Conditional Award to the successful low bidder on or before November 7, with contract execution by November 16, 2018.</p> <p>The successful contractor should submit required paperwork (insurance certificate, bonds, etc.) prior to contract execution. Contractor should after issuance of Notice to Begin Work and commence work immediately with submittals and shop drawings. On site work should begin December 3, 2018, and Substantial Completion must be achieved within 150 days, with final completion 15 days later.</p>
Questions	<p>Questions from Attendees. Answers/Direction will be a component of Addendum #1.</p>
Bid Documents	<p>Obtain Bid Package – ARC Document Solutions, Farmington, CT 860-677-8817</p>
Addendum	<p>All Addenda will be available on the ARC website http://www.e-arc.com/location/farmington/, DAS website, and Town website.</p> <p>Addendum No. 1 will be issued by end of day Wednesday 17 October 2018 to all attending Firms.</p>

THESE MINUTES REFLECT OUR UNDERSTANDING OF THE BUSINESS TRANSACTED AND DECISIONS OR STATEMENTS MADE AT THIS MEETING. PLEASE PROVIDE CORRECTIONS OR ADDITIONS TO OUR OFFICE WITHIN 5 DAYS OF DATE STATED BELOW. *Note: Items in italics happened after the Meeting and are included for clarification purposes.*

Respectfully Submitted,

Meghan Brennan

Dist. to: All attendees and known Plan Holders (via Addendum #1), Simsbury Town Engineer, Simsbury Public Library, JR Russo, Consulting Engineering Services, BRMA file

SIGN IN SHEET

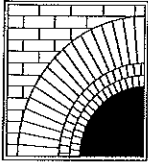

**BUTLER
ROWLAND
MAYS**
ARCHITECTS,
LLP

Town of Simsbury
Lower Level Improvements for the
Simsbury Public Library

Town Project: 18-05
BRMA Project: 16.39.28
BID DUE DATE: 24 October 2018

NAME (Please Print)	REPRESENTING	EMAIL & PHONE NUMBER
Brian Doyard	Network Design & Construction	brian.doyard@ndecorp.com 860-681-7843
MIKE SAK	ALL STATE CONSTRUCTION	MSAK@ALLSTATECONSTRUCTIONINC.COM 860-914-8908
Vince Parete	Larosa Building Group	vparete@larosabg.com (203) 235-1770
Jon Stockford	Pioneer Builders	jon@pioneerbuildersct.com 860-550-1137
Erik Pedersen	ELM Electrical	epedersen@elmelec.com 413 348 9308
Walter Lehner	Nosal Builders	(203) 525-2405 wlehner@nosalbuilders.com
MICHAEL MORRIS	LLB ARCHITECTS	401 421 7715 MMORRIS@LLBARCH.COM 860-291-9448
MICHAEL GARNEAU	W.S. MOUNTFORD CO.	MGARNEAU@WSMOUNTFORD.COM
mark JACOBS	Valley Electric	mark.valleyelectric@gmail.com
MORGAN NEWATON	Kronerburger & Son	estimating@kronerburgerjones.com
Moe Villano	CT Carpentry Corp	Estimating@CTCarpentry.com 860-571-8812

#299337
Revised 4/2014

128P-SC-17 (grant #)

CONNECTICUT STATE LIBRARY
Hartford, Connecticut 06106

STATE PUBLIC LIBRARY CONSTRUCTION GRANT CONTRACT
FOR MUNICIPALITIES

This Agreement is made by and between the State of Connecticut, Connecticut State Library Board (hereinafter "State Library" or "Grantor") and the Town of Simsbury (hereinafter "Contractor" or "Grantee") pursuant to § 11-24c of the Connecticut General Statutes (hereinafter "CGS").

WHEREAS, CGS § 11-24c provides for state funds to assist in the construction, renovation, repair, and improvement of the physical public library facilities at the local level; and

WHEREAS, the State Library administers a grant program whereby libraries apply for state funded public library construction grants; and

NOW THEREFORE, in consideration of the aforesaid and the mutual promises hereinafter contained, the parties do hereby agree as follows:

1. The State Library hereby authorizes a grant for the amount not to exceed \$405,525 (hereinafter "Grant Funds") for major alteration project at the Simsbury Public Library (hereinafter the "Project"). The Contractor is responsible for any project expenses greater than the Grant Funds.
2. The Contractor shall proceed forthwith upon the signing of this Agreement with the major alteration project provided that sufficient local funds are approved and available to complete the entire project in accordance with said plans, specifications, and schedule or as hereafter changed with the approval of the State Library.
3. For projects that involve construction the Contractor has employed an architect and shall submit to the state detailed plans and specifications (including *American Institute of Architects (AIA) Document A201*, general conditions of the contract for construction intended to be used as one of the contract documents forming the construction contract).
4. The Contractor may, in writing, execute change orders in connection with this particular project with the written approval of the architect, but any individual change representing an increase or decrease in the cost of the project in excess of \$4,000 for projects under \$50,000, \$10,000 for projects between \$50,000 and \$100,000 and \$20,000 for projects over \$100,000 shall be approved in advance by the State Library.
5. The Contractor shall establish and maintain accounting procedures and supporting documents necessary to permit accurate and expeditious audit at any time during the construction, and all records pertaining to the project shall be maintained for a period of ten (10) years.
6. Upon request of the State Library, the Contractor shall submit copies of architect's and other inspection reports and such additional reports including payroll records as may be required by the State Library.

7. Payment to the Contractor under this contract is subject to receipt of state funds by the State Library. Once the funds become available, payment shall be made in accordance with the following pre-established schedule:
 - (a) Fifty percent (50%) of the grant upon submission of an Application for Payment, example attached hereto as Attachment A, and certification by the architect that work in place, services rendered, and equipment delivered and installed on the project represent not less than fifty percent (50%) of the total project value, i.e., of all construction, all equipment, etc. Documentation consists of *AIA Documents G702* and *G703*, the architect's application and certification for payment, and invoices for expenses listed in the Budget Information section of the application as submitted to the State Library and which are not included in the *AIA Documents G702* and *G703*.
 - (b) An additional forty percent (40%) of the grant in accordance with the same provisions when the architect certifies seventy-five percent (75%) completion; and,
 - (c) The final ten percent (10%) of the grant upon submission of an Application for Payment, the architect's certification of one hundred percent (100%) completion. In those cases where there may be a significant delay in certifying 100% completion, libraries may be eligible for their last payment when they have a certificate of occupancy for the entire affected library space and they can prove they have incurred costs that are at least double their grant award. In order for the Contractor to receive its final payment, it shall also furnish the following to the State Library:
 - (1) The final *AIA Documents G702* and *G703* with "paid" written on the AIA document or payment voucher for final payment of the project.
 - (2) For projects of \$2,000,000 or less, invoices for expenses listed in the Budget Information section under Project Cost Estimate in the application as submitted to the State Library excluding the expenses covered in the *AIA documents G702* and *G703*.
 - (3) A Final Expenditure Report, example attached hereto as Attachment C.
 - (4) The Contractor expressly agrees and understands that the Application for Payment of the final ten percent (10%) of the grant and all required back-up documentation must be received by the State Library on or before the last day of this grant agreement before any final payment, if warranted, shall be made by the State Library. The failure to provide the Application for Payment and back-up documentation within the time required is an express waiver by the Contractor of any right to final payment under the grant.
 - (d) The Contractor may combine payment requests in one Application for Payment attached hereto as Attachment B.
8. The Contractor shall comply with, the requirements and provisions of CGS § 11-24c, the regulations thereunder, the *State Grant Programs for Public Library Construction Timetable and Guidelines* and the regulations thereunder, including the anti-discrimination requirements (Title VI, Civil Rights Act, 1964, Pub. L No. 88-352, § 504 of the Rehabilitation Act of 1973, the Americans with Disabilities Act) and the prevailing State Wage Requirements.

9. The Contractor shall employ adequate methods of obtaining competitive bids, pursuant to the Department of Administrative Services (DAS) Contractor Prequalification Program, prior to awarding the construction contract, and shall advertise in a newspaper having a substantial circulation in the municipality in which construction takes place (a trade journal does not qualify as a newspaper for this purpose) or advertise in the DAS Biznet State Contracting Portal.
 - (a) For a single construction contract with total cost under \$500,000. All construction contracts (including equipment procurement over \$10,000) shall be awarded to the lowest responsible and qualified bidder in open competitive bidding.
 - (b) For a single construction contract with total cost over \$500,000. All construction contracts for construction projects which are funded in whole or in part with state funds shall be awarded to the lowest responsible and pre-qualified bidder described in CGS § 4b-92 in open competitive bidding. The Contractor will provide those contractors with a Performance Evaluation at 50% project completion and provide both contractor and DAS with a Performance Evaluation at 100% completion. The Contractor must indicate in the bid advertisement the classification(s) for which construction contractors are being sought. Example of bid advertisement can found on DAS Contractor Prequalification Program website. The DAS Prequalification Program must receive the final evaluation seventy (70) days after project completion.
10. The Contractor shall not sign a contract with a building contractor, purchase furniture, or begin work on a maintenance project (only applicable to "distressed municipalities" as defined by CGS § 32-9p(b)) until the Contractor and the State Librarian have signed this contract, and this contract has been approved by the Attorney General.
11. The building contractor who is selected to do the project shall provide a performance bond.
12. The Contractor shall comply with all applicable sections of the State and local building codes, where such codes are in force.
13. The Contractor shall follow the rules on construction of a public works project as established by the local municipality unless additional requirements are specifically required by Federal statutes, State statutes, or executive orders.
14. Indemnification.
 - (a) The Contractor shall indemnify, defend and hold harmless the State and its officers, representatives, agents, servants, employees, successors and assigns from and against any and all (1) claims arising, directly or indirectly, in connection with the Contract, including the acts of commission or omission (collectively, the "Acts") of the Contractor or contractor parties; and (2) liabilities, damages, losses, costs and expenses, including but not limited to, attorneys' and other professionals' fees, arising, directly or indirectly, in connection with claims, Acts or the contract. The Contractor shall use counsel reasonably acceptable to the State in carrying out its obligations under this section. The Contractor's obligations under this section to indemnify, defend and hold harmless against claims includes claims concerning confidentiality of any part of or all of the Contractor's bid, proposal or any records, any intellectual property rights, other proprietary rights of any person or entity, copyrighted or uncopyrighted compositions, secret processes, patented or unpatented inventions, articles or appliances furnished or used in the performance.

- (b) The Contractor shall not be responsible for indemnifying or holding the State harmless from any liability arising due to the negligence of the State or any third party acting under the direct control or supervision of the State.
- (c) The Contractor shall reimburse the State for any and all damages to the real or personal property of the State caused by the Acts of the Contractor or any contractor parties. The State shall give the Contractor reasonable notice of any such claims.
- (d) The Contractor's duties under this section shall remain fully in effect and binding in accordance with the terms and conditions of the Contract, without being lessened or compromised in any way, even where the Contractor is alleged or is found to have merely contributed in part to the Acts giving rise to the claims and/or where the State is alleged or is found to have contributed to the Acts giving rise to the claims.
- (e) The Contractor shall carry and maintain at all times during the term of the Contract, and during the time that any provisions survive the term of the Contract, sufficient general liability insurance to satisfy its obligations under this Contract. The Contractor shall name the State as an additional insured on the policy and shall provide a copy of the policy to the State Library prior to the effective date of the Contract. The Contractor shall not begin performance until the delivery of the policy to the State Library. The State Library shall be entitled to recover under the insurance policy even if a body of competent jurisdiction determines that the State Library or the State is contributorily negligent.
- (f) This section shall survive the termination of the contract and shall not be limited by reason of any insurance coverage.

15. Audit requirements.

- (a) For State-funded grant contracts where the Contractor has or will receive \$300,000 or more in any State grant(s) during the Contractor's fiscal year, the following audit provision must be present:

Audit Requirements for State Grants. For purposes of this clause, the word "Contractor" shall be read to mean "nonstate entity," as that term is defined in Conn. Gen. Stat. § 4-230. The Contractor shall provide for an annual financial audit acceptable to the State Library for any expenditure of State-awarded funds made by the Contractor. Such audit shall include management letters and audit recommendations. The State Auditors of Public Accounts shall have access to all records and accounts for the fiscal year(s) in which the award was made. The Contractor will comply with federal and State single audit standards as applicable.

- (b) The Contractor shall make all of its and the Contractor Parties' Records available at all reasonable hours for audit and inspection by the State, including, but not limited to, the Agency, the Connecticut Auditors of Public Accounts, Attorney General and State's Attorney and their respective agents. Requests for any audit or inspection shall be in writing, at least ten (10) days prior to the requested date. All audits and inspections shall be at the requester's expense. The State may request an audit or inspection at any time during the Contract term and for three (3) years after Termination, Cancellation or Expiration of the Contract. The Contractor shall cooperate fully with the State and its agents in connection with an audit or inspection. Following any audit or inspection, the State may conduct and the Contractor shall cooperate with an exit conference.

- (c) For purposes of this subsection, for State Grants, the word "Contractor" shall be read to mean "nonstate entity," as that term is defined in CGS§ 4-230.
16. The Contractor shall refund any amounts found to be owing to the State as a result of an error or the discovery of any fraud, collusion, or illegal actions, and shall make such refunds within thirty (30) days from notice in writing by the State. In the case of any failure to make such refunds, the Contractor agrees that the State may deduct such amount from any current or future sums owing to said Contractor on the part of the State from any source or for any purpose whatsoever.
17. If the final Application for Payment and back-up documentation reveals that the ultimate cost of the construction project for which this grant has been provided is less than the amount upon which the grant award was originally based (the grant award cannot exceed one half of the actual cost of the construction project) the amount of the grant award shall be reduced proportionately. If any funds must be returned, the Contractor shall send the refund, in the form of a bank or certified check, to the Connecticut State Library within thirty (30) days from notice in writing by the State Library, without the parties to this agreement entering into separate amendments or supplements to this Agreement.
18. When issuing statements, press releases, announcements of contract awards under the project, dedication programs and other documents or announcements describing this project, the Contractor shall state clearly that the library construction project is being paid for, in part, with state funds provided by the Connecticut State Library.
19. The Contractor expressly agrees and covenants that a proposed new, improved or expanded public library facility that is the subject of this contract shall be devoted to public library purposes for a period of not less than ten (10) years after completion of the construction project for which this grant has been provided or until the building outlives its usefulness. The Contractor further expressly agrees and covenants that, should a proposed new, improved or expanded public library facility be devoted to public library purposes for a period of less than ten (10) years after completion of the construction project or until the building outlives its usefulness, the contractor shall return the grant funds provided for herein on a prorated basis for every year less than ten (10) years after completion that the facility was not devoted to use as a public library.
20. Termination.
- (a) Notwithstanding any provisions in this contract, the State Library, through a duly authorized employee, may terminate the contract whenever the State Library makes a written determination that such termination is in the best interests of the State. The State Library shall notify the Contractor in writing of termination pursuant to this section, which notice shall specify the effective date of termination and the extent to which the Contractor must complete its performance under the contract prior to such date.
- (b) Notwithstanding any provisions in this contract, the State Library, through a duly authorized employee, may, after making a written determination that the Contractor has breached the contract, terminate the contract in accordance with the following breach provision.
- (1) Breach. If either party breaches the contract in any respect, the non-breaching party shall provide written notice of the breach to the breaching party and afford the breaching party an opportunity to cure within ten (10) days from the date that the breaching party receives the notice. In the case of a Contractor breach, any other time period which the State

Library sets forth in the notice shall trump the ten (10) days. The right to cure period shall be extended if the non-breaching party is satisfied that the breaching party is making a good faith effort to cure but the nature of the breach is such that it cannot be cured within the right to cure period. The notice may include an effective contract termination date if the breach is not cured by the stated date and, unless otherwise modified by the non-breaching party in writing prior to the termination date, no further action shall be required of any party to effect the termination as of the stated date. If the notice does not set forth an effective contract termination date, then the non-breaching party may terminate the contract by giving the breaching party no less than twenty four (24) hours' prior written notice. If the State Library believes that the Contractor has not performed according to the contract, the State Library may withhold payment in whole or in part pending resolution of the performance issue, provided that the State Library notifies the Contractor in writing prior to the date that the payment would have been due.

- (c) The State Library shall send the notice of termination via certified mail, return receipt requested, to the Contractor at the most current address which the Contractor has furnished to the State Library for purposes of correspondence, or by hand delivery. Upon receiving the notice from the State Library, the Contractor shall immediately discontinue all services affected in accordance with the notice, undertake all State Library all records. The records are deemed to be the property of the State Library and the Contractor shall deliver them to the State Library no later than thirty (30) days after the termination of the contract or fifteen (15) days after the Contractor receives a written request from the State Library for the records. The Contractor shall deliver those records that exist in electronic, magnetic or other intangible form in a non-proprietary format, such as, but not limited to, ASCII or .TXT.
- (d) Upon receipt of a written notice of termination from the State Library, the Contractor shall cease operations as the State Library directs in the notice, and take all actions that are necessary or appropriate, or that the State Library may reasonably direct, for the protection, and preservation of the goods and any other property. Except for any work which the State Library directs the Contractor to perform in the notice prior to the effective date of termination, and except as otherwise provided in the notice, the Contractor shall terminate or conclude all existing subcontracts and purchase orders and shall not enter into any further subcontracts, purchase orders or commitments.
- (e) The State Library shall, within forty-five (45) days of the effective date of termination, reimburse the Contractor for its performance rendered and accepted by the State Library in accordance with the terms of this contract, in addition to all actual and reasonable costs incurred after termination in completing those portions of the performance which the notice required the Contractor to complete. However, the Contractor is not entitled to receive and the State Library is not obligated to tender to the Contractor any payments for anticipated or lost profits. Upon request by the State Library, the Contractor shall assign to the State Library, or any replacement Contractor which the State Library designates, all subcontracts, purchase orders and other commitments, deliver to the State Library all records and other information pertaining to its performance, and remove from State premises, whether leased or owned, all of Contractor's property, equipment, waste material and rubbish related to its performance, all as the State Library may request.
- (f) For breach or violation of any of the provisions in the section concerning representations and warranties, the State Library may terminate the contract in accordance with its terms and

revoke any consent to assignments given as if the assignments had never been requested or consented to, without liability to the Contractor or Contractor parties or any third party.

(g) Upon termination of the contract, all rights and obligations shall be null and void, so that no party shall have any further rights or obligations to any other party, except with respect to the sections which survive termination. All representations, warranties, agreements and rights of the parties under the contract shall survive such termination to the extent not otherwise limited in the contract and without each one of them having to be specifically mentioned in the contract.

(h) Termination of the contract pursuant to this section shall not be deemed to be a breach of contract by the State Library.

21. Forum and Choice of Law. The parties deem the Contract to have been made in the City of Hartford, State of Connecticut. Both parties agree that it is fair and reasonable for the validity and construction of the contract to be, and it shall be, governed by the laws and court decisions of the State of Connecticut, without giving effect to its principles of conflicts of laws. To the extent that any immunities provided by Federal law or the laws of the State of Connecticut do not bar an action against the State, and to the extent that these courts are courts of competent jurisdiction, for the purpose of venue, the complaint shall be made returnable to the Judicial District of Hartford only or shall be brought in the United States District Court for the District of Connecticut only, and shall not be transferred to any other court, provided, however, that nothing here constitutes a waiver or compromise of the sovereign immunity of the State of Connecticut. The Contractor waives any objection which it may now have or will have to the laying of venue of any claims in any forum and further irrevocably submits to such jurisdiction in any suit, action or proceeding.
22. Executive Orders. This Contract is subject to the provisions of Executive Order No. Three of Governor Thomas J. Meskill, promulgated June 16, 1971, concerning labor employment practices, Executive Order No. Seventeen of Governor Thomas J. Meskill, promulgated February 15, 1973, concerning the listing of employment openings and Executive Order No. Sixteen of Governor John G. Rowland promulgated August 4, 1999, concerning violence in the workplace, all of which are incorporated into and are made a part of the Contract as if they had been fully set forth in it. The Contract may also be subject to Executive Order No. 14 of Governor M. Jodi Rell, promulgated April 17, 2006, concerning procurement of cleaning products and services and to Executive Order No. 49 of Governor Dannel P. Malloy, promulgated May 22, 2015, mandating disclosure of certain gifts to public employees and contributions to certain candidates for office. If Executive Order 14 and/or Executive Order 49 are applicable, they are deemed to be incorporated into and are made a part of the Contract as if they had been fully set forth in it. At the Contractor's request, the Client Agency or Connecticut Department of Administrative Services shall provide a copy of these orders to the Contractor.
23. The State of Connecticut shall assume no liability for payment for services under the terms of this agreement until the contractor is notified that the State Library and the Attorney General of the State of Connecticut have approved this Agreement in writing.
24. This Agreement shall be binding upon and shall inure to the benefit of the Contractor and its successor.
25. The sole and exclusive means for the presentation of any claim against the State arising from this Agreement shall be in accordance with Chapter 53 of the Connecticut General Statutes (Claims

against the State) and the Contractor shall not initiate legal proceedings in any State or Federal Court in addition to or in lieu of said Chapter 53 proceedings.

26. A Contractor receiving a grant of \$500,000 or more shall display a sign at the site during construction indicating that the project is funded, in part, with a grant from the State of Connecticut. An example will be furnished by the State Library.
27. Audit and Inspection of Plants, Places of Business and Records.
- (a) The State and its agents, including, but not limited to, the Connecticut Auditors of Public Accounts, Attorney General and State's Attorney and their respective agents, may, at reasonable hours, inspect and examine all of the parts of the Contractor's and Contractor Parties' plants and places of business which, in any way, are related to, or involved in, the performance of this Contract.
 - (b) The Contractor shall maintain, and shall require each of the Contractor Parties to maintain, accurate and complete Records. The Contractor shall make all of its and the Contractor Parties' Records available at all reasonable hours for audit and inspection by the State and its agents.
 - (c) The State shall make all requests for any audit or inspection in writing and shall provide the Contractor with at least twenty-four (24) hours' notice prior to the requested audit and inspection date. If the State suspects fraud or other abuse, or in the event of an emergency, the State is not obligated to provide any prior notice.
 - (d) All audits and inspections shall be at the State's expense.
 - (e) The Contractor shall keep and preserve or cause to be kept and preserved all of its and Contractor Parties' Records until three (3) years after the latter of (i) final payment under this Agreement, or (ii) the expiration or earlier termination of this Agreement, as the same may be modified for any reason. The State may request an audit or inspection at any time during this period. If any Claim or audit is started before the expiration of this period, the Contractor shall retain or cause to be retained all Records until all Claims or audit findings have been resolved.
 - (f) The Contractor shall cooperate fully with the State and its agents in connection with an audit or inspection. Following any audit or inspection, the State may conduct and the Contractor shall cooperate with an exit conference.
 - (g) The Contractor shall incorporate this entire Section verbatim into any contract or other agreement that it enters into with any Contractor Party.
28. Summary of State Ethics Laws. Pursuant to the requirements of section 1-101qq of the Connecticut General Statutes, the summary of State ethic laws developed by the State Ethics Commission pursuant to section 1-81b of the Connecticut General Statutes is incorporated by reference into and made a part of the contract as if the summary had been fully set forth in the contract.
29. Whistleblower. This contract may be subject to the provisions of Section 4-61dd of the Connecticut General Statutes. In accordance with this statute, if an officer, employee or

appointing authority of the Contractor takes or threatens to take any personnel action against any employee of the Contractor in retaliation for such employee's disclosure of information to any employee of the contracting state or quasi-public agency or the Auditors of Public Accounts or the Attorney General under the provisions of subsection (a) of such statute, the Contractor shall be liable for a civil penalty of not more than five thousand dollars for each offense, up to a maximum of twenty per cent of the value of this contract. Each violation shall be a separate and distinct offense and in the case of a continuing violation, each calendar day's continuance of the violation shall be deemed to be a separate and distinct offense. The State may request that the Attorney General bring a civil action in the Superior Court for the Judicial District of Hartford to seek imposition and recovery of such civil penalty. In accordance with subsection (f) of such statute, each large state contractor, as defined in the statute, shall post a notice of the provisions of the statute relating to large state contractors in a conspicuous place which is readily available for viewing by the employees of the contractor.

30. Disclosure of Records. This Contract may be subject to the provisions of section 1-218 of the Connecticut General Statutes. In accordance with this statute, each contract in excess of two million five hundred thousand dollars between a public agency and a person for the performance of a governmental function shall (a) provide that the public agency is entitled to receive a copy of records and files related to the performance of the governmental function, and (b) indicate that such records and files are subject to the Freedom of Information Act (FOIA) and may be disclosed by the public agency pursuant to FOIA. No request to inspect or copy such records or files shall be valid unless the request is made to the public agency in accordance with FOIA. Any complaint by a person who is denied the right to inspect or copy such records or files shall be brought to the Freedom of Information Commission in accordance with the provisions of sections 1-205 and 1-206 of the Connecticut General Statutes.
31. Sovereign Immunity. The parties acknowledge and agree that nothing in this Contract shall be construed as a modification, compromise or waiver by the State of any rights or defenses of any immunities provided by Federal law or the laws of the State of Connecticut to the State or any of its officers and employees, which they may have had, now have or will have with respect to all matters arising out of this Contract. To the extent that this section conflicts with any other section, this section shall govern.
32. Entire Agreement. This written contract shall constitute the entire agreement between the parties and no other terms and conditions in any document, acceptance or acknowledgment shall be effective or binding unless expressly agreed to in writing by State Library. This contract may not be changed other than by a formal written contract amendment signed by the parties hereto and approved by the Connecticut Attorney General.
33. State Library approved this grant on November 27, 2017. Minutes of that meeting are attached hereto as Attachment A and expressly made a part hereof.

State Public Library Construction Grant - Municipalities
Page 10 of 14

GRANTEE

March 1, 2018 to February 28, 2023
Contract Period

Town of Simsbury
Legal Name (Town, City, Corporation, etc.)

06-6002085
Federal Employer I.D. Number

Maria E. Capriola
Signature of Authorized Individual

3/13/18
Date

Maria E Capriola
Typed Name of Authorized Individual

Town Manager
Title
(Grantee Affix Seal Here)

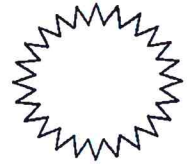

CONNECTICUT STATE LIBRARY BOARD

Kendall F. Wiggins
Kendall F. Wiggins, State Librarian

3/23/18
Date

128P-SC-17
Grant Number

This contract template, having been reviewed and approved by the Office of the Attorney General (OAG), it is exempt from review pursuant to a Memorandum of Agreement between the State Library and the OAG dated June 11, 2014.

Fund	Department	SID	Program	Acct.	Project	Budg. Ref.	Amt.
12052	CSL66051	43648	85006	55070	CSL Non. Proj.	2018	\$405,525

STATE OF CONNECTICUT
RECORD OF PROCEEDINGS STATE LIBRARY BOARD
November 27, 2017

Present: John N. Barry, Bob Harris, Allen Hoffman, Mary Etter, Jay Johnston, Comm. Dianna Wentzell,
Alison Clemens

Members absent: Judge Michael Sheldon, Sandy Ruoff, Matt Poland, Justice Andrew McDonald

Others present: Kendall Wiggin, Jane Beaudoin, Dawn La Valle, Robert Kinney, Lizette Pelletier, LeAnn
Power, (State Library), Glenn Grube (Avon Free Public Library/CLA), Kate Byroade (Cragin Memorial
Library, Colchester), Lisa Karim (Simsbury Public Library)

The meeting was called to order at 1:10 p.m. by Chairperson John N. Barry.

...

NEW BUSINESS

...

State Public Library Construction Grant Recommendations: It was immediately MOVED (A. Hoffman)
seconded (B. Harris) THAT THE STATE LIBRARY BOARD AWARDS THE FOLLOWING STATE
PUBLIC LIBRARY CONSTRUCTION GRANTS:

\$1,000,000 to the City of Bridgeport for a new Newfield Branch of the Bridgeport Public Library,

\$1,000,000 to the Old Lyme-Phoebe Griffin Noyes Library Association, Inc.,

\$405,525 to the Town of Simsbury for the Simsbury Public Library,

\$75,000 to the Brainerd Memorial Library, Inc., of Haddam

\$212,750 to the Town of Milford for the Milford Public Library,

\$108,452 to the Town of Portland for the Portland Public Library.

PASSED unanimously..

...

The meeting was adjourned at 1:45 p.m. The next meeting is scheduled for Monday, January 22, 2018, at 1:00
p.m. in the State Library's Reading Room.

Respectfully submitted,

Kendall F. Wiggin, Secretary

Jane Beaudoin, Recorder

CONNECTICUT STATE LIBRARY
APPLICATION FOR PAYMENT
STATE PUBLIC LIBRARY CONSTRUCTION GRANT
Under Section 11-24c of the Connecticut General Statutes

CERTIFICATION

The _____ (grantee) hereby requests a payment of grant funds to be expended for the below named project as authorized under the State Public Library Construction Grant program administered by the Connecticut State Library Board (grantor). Acting as the duly authorized agent for the above, I hereby certify that, according to the best of my knowledge, the information given below is correct and that the grantee is in compliance with the terms and conditions of the grant agreement between the grantee and the Connecticut State Library Board.

Name: _____ Signed: _____

Title: _____ Date: _____

A. Grant Number # _____

B. Total amount of grant approved: \$ _____

C. Contract period: _____ to _____

D. Organization authorized to receive payment: _____
Name _____

Address _____

E. Are you prepared to receive payment through ACH (Automated Clearing House)? (Check one) Yes No

1. Original estimated cost of entire project: \$ _____
(as given in the grant application)

2. Increase or decrease in project costs since the project began (if any): \$ _____

3. Total new cost of entire project (add items 1 and 2): \$ _____

4. Total amount completed to date: (Must be substantiated by architect's certification on the most recent *AIA Documents G702* and *G703* and invoices for costs not covered by the *AIA Documents*.) \$ _____

5. Dollar amount of grant payment being requested: \$ _____

6. Payment # 1 (50%) 2 (40%) 3 (10%)

7. Municipal Library: or Association Library: FEIN: _____

State of Connecticut, County of _____ on this _____ day of _____

the above subscribed personally appeared before me and made oath to the truth of this certification.

My commission expires on _____ Signed _____

CONNECTICUT STATE LIBRARY
STATE PUBLIC LIBRARY CONSTRUCTION GRANT
FINAL EXPENDITURE REPORT

In order to receive the final payment and close out your State Public Library Construction Grant you must complete this Final Expenditure Report and submit it to the State Library along with the final *ALA Documents G702* and *G703* marked PAID, and invoices to substantiate expenses. These materials must be received by the State Library on or before the last day of your grant contract.

Grantee: _____

Grant #: _____

Library Name: _____

1. Project Type (Place an X in front of those categories which apply):

- | | | |
|-------------------------------------------|-------------------------------------------------------|----------------------------------------------------|
| <input type="checkbox"/> New Construction | <input type="checkbox"/> Conversion of existing bldg. | <input type="checkbox"/> Handicapped Accessibility |
| <input type="checkbox"/> Renovation | <input type="checkbox"/> Code Compliance | <input type="checkbox"/> Energy Conservation |
| <input type="checkbox"/> Addition | <input type="checkbox"/> Remodeling | <input type="checkbox"/> Maintenance |

Please indicate the actual amount spent in each category indicated below.

2. Non Construction Costs

- | | |
|------------------------------------------------------------------------------------------------------|----------|
| a. Land | \$ _____ |
| b. Easement, development rights, and other interests in land | \$ _____ |
| c. Building/structures | \$ _____ |
| d. Equipment/machinery/furnishings | \$ _____ |
| e. Other (must be identified) | \$ _____ |
| _____ | \$ _____ |
| _____ | \$ _____ |
| _____ | \$ _____ |
| f. Feasibility, architectural, engineering studies, and costs related to the above acquisition costs | \$ _____ |
| g. Environmental remediation | \$ _____ |

TOTAL NON-CONSTRUCTION COSTS \$ _____

Final Expenditure Report
Page 2

- 3. Construction Costs
 - a. Building construction \$ _____
 - b. Demolition \$ _____
 - c. Site improvements \$ _____
 - d. Parking lot \$ _____
 - e. Architect/engineers' fees \$ _____
 - f. Audit \$ _____
 - g. Other (must be identified) \$ _____
 - _____ \$ _____
 - _____ \$ _____
 - _____ \$ _____

TOTAL CONSTRUCTION COSTS \$ _____

**TOTAL
NON-CONSTRUCTION AND CONSTRUCTION COSTS** \$ _____

4. Funding Sources

State Public Library
Construction Grant \$ _____

Other State \$ _____

Federal \$ _____

Private (fund raising) \$ _____

Foundation/Trust \$ _____

Local (general budget) \$ _____

TOTAL \$ _____ (must equal 100% of total project cost)

5. Name and signature of the Grantee's authorized representative:

(Print or Type)

(Signature)

Project: Simsbury Public Library Phase I Lower Level Improvements

**Minimum Rates and Classifications
for Building Construction**

ID# : B 25299

**Connecticut Department of Labor
Wage and Workplace Standards Division**

By virtue of the authority vested in the Labor Commissioner under provisions of Section 31-53 of the General Statutes of Connecticut, as amended, the following are declared to be the prevailing rates and welfare payments and will apply only where the contract is advertised for bid within 20 days of the date on which the rates are established. Any contractor or subcontractor not obligated by agreement to pay to the welfare and pension fund shall pay this amount to each employee as part of his/her hourly wages.

Project Number: 18-05

Project Town: Simsbury

State#:

FAP#:

Project: Simsbury Public Library Phase I Lower Level Improvements

CLASSIFICATION	Hourly Rate	Benefits
1a) Asbestos Worker/Insulator (Includes application of insulating materials, protective coverings, coatings, & finishes to all types of mechanical systems; application of firestopping material for wall openings & penetrations in walls, floors, ceilings	38.25	27.96
<hr/>		
1b) Asbestos/Toxic Waste Removal Laborers: Asbestos removal and encapsulation (except its removal from mechanical systems which are not to be scrapped), toxic waste removers, blasters.**See Laborers Group 7**		
<hr/>		
1c) Asbestos Worker/Heat and Frost Insulator	40.21	29.30

As of: Friday, September 21, 2018

Project: Simsbury Public Library Phase I Lower Level Improvements

2) Boilermaker	38.34	26.01
----------------	-------	-------

3a) Bricklayer, Cement Mason, Concrete Finisher (including caulking), Stone Masons	33.48	32.06 + a
---------------------------------------------------------------------------------------	-------	-----------

3b) Tile Setter	34.90	25.87
-----------------	-------	-------

3c) Terrazzo Mechanics and Marble Setters	31.69	22.35
-------------------------------------------	-------	-------

3d) Tile, Marble & Terrazzo Finishers	26.70	21.75
---------------------------------------	-------	-------

3e) Plasterer	33.48	32.06
---------------	-------	-------

As of: Friday, September 21, 2018

Project: Simsbury Public Library Phase I Lower Level Improvements

-----LABORERS-----

4) Group 1: Laborers (common or general), acetylene burners, carpenter tenders, concrete specialists, wrecking laborers, fire watchers.	30.05	20.10
-----------------------------------------------------------------------------------------------------------------------------------------	-------	-------

4a) Group 2: Mortar mixers, plaster tender, power buggy operators, powdermen, fireproofers/mixer/nozzleman (Person running mixer and spraying fireproof only).	30.30	20.10
----------------------------------------------------------------------------------------------------------------------------------------------------------------	-------	-------

4b) Group 3: Jackhammer operators/pavement breaker, mason tender (brick), mason tender (cement/concrete), forklift operators and forklift operators (masonry).	30.55	20.10
----------------------------------------------------------------------------------------------------------------------------------------------------------------	-------	-------

4c) **Group 4: Pipelayers (Installation of water, storm drainage or sewage lines outside of the building line with P6, P7 license) (the pipelayer rate shall apply only to one or two employees of the total crew who primary task is to actually perform the mating of pipe sections) P6 and P7 rate is \$26.80.	30.55	20.10
-------------------------------------------------------------------------------------------------------------------------------------------------------------------------------------------------------------------------------------------------------------------------------------------------------------------	-------	-------

4d) Group 5: Air track operator, sand blaster and hydraulic drills.	30.55	20.10
---------------------------------------------------------------------	-------	-------

As of: Friday, September 21, 2018

Project: Simsbury Public Library Phase I Lower Level Improvements

4e) Group 6: Blasters, nuclear and toxic waste removal.	31.80	20.10
---------------------------------------------------------	-------	-------

4f) Group 7: Asbestos/lead removal and encapsulation (except it's removal from mechanical systems which are not to be scrapped).	31.05	20.10
----------------------------------------------------------------------------------------------------------------------------------	-------	-------

4g) Group 8: Bottom men on open air caisson, cylindrical work and boring crew.	28.38	20.10
--------------------------------------------------------------------------------	-------	-------

4h) Group 9: Top men on open air caisson, cylindrical work and boring crew.	27.86	20.10
-----------------------------------------------------------------------------	-------	-------

4i) Group 10: Traffic Control Signalman	16.00	20.10
-----------------------------------------	-------	-------

5) Carpenter, Acoustical Ceiling Installation, Soft Floor/Carpet Laying, Metal Stud Installation, Form Work and Scaffold Building, Drywall Hanging, Modular-Furniture Systems Installers, Lathers, Piledrivers, Resilient Floor Layers.	32.60	25.34
-----------------------------------------------------------------------------------------------------------------------------------------------------------------------------------------------------------------------------------------	-------	-------

As of: Friday, September 21, 2018

Project: Simsbury Public Library Phase I Lower Level Improvements

5a) Millwrights	33.14	25.74
-----------------	-------	-------

6) Electrical Worker (including low voltage wiring) (Trade License required: E1,2 L-5,6 C-5,6 T-1,2 L-1,2 V-1,2,7,8,9)	40.00	25.97+3% of gross wage
------------------------------------------------------------------------------------------------------------------------	-------	------------------------

7a) Elevator Mechanic (Trade License required: R-1,2,5,6)	51.71	32.645+a+b
-----------------------------------------------------------	-------	------------

-----LINE CONSTRUCTION-----

Groundman	26.50	6.5% + 9.00
-----------	-------	-------------

Linemen/Cable Splicer	48.19	6.5% + 22.00
-----------------------	-------	--------------

As of: Friday, September 21, 2018

Project: Simsbury Public Library Phase I Lower Level Improvements

8) Glazier (Trade License required: FG-1,2) 37.18 21.05 + a

9) Ironworker, Ornamental, Reinforcing, Structural, and Precast Concrete Erection 35.47 35.14 + a

----OPERATORS----

Group 1: Crane handling or erecting structural steel or stone, hoisting engineer 2 drums or over, front end loader (7 cubic yards or over), work boat 26 ft. and over and Tunnel Boring Machines. (Trade License Required) 39.55 24.05 + a

Group 2: Cranes (100 ton rate capacity and over); Excavator over 2 cubic yards; Piledriver (\$3.00 premium when operator controls hammer); Bauer Drill/Caisson. (Trade License Required) 39.23 24.05 + a

Group 3: Excavator; Backhoe/Excavator under 2 cubic yards; Cranes (under 100 ton rated capacity), Grader/Blade; Master Mechanic; Hoisting Engineer (all types of equipment where a drum and cable are used to hoist or drag material regardless of motive power of operation), Rubber Tire Excavator (Drott-1085 or similar); Grader Operator; Bulldozer Fine Grade. (slopes, shaping, laser or GPS, etc.). (Trade License Required) 38.49 24.05 + a

As of: Friday, September 21, 2018

Project: Simsbury Public Library Phase I Lower Level Improvements

Group 4: Trenching Machines; Lighter Derrick; Concrete Finishing Machine; CMI Machine or Similar; Koehring Loader (Skooper).	38.10	24.05 + a
------------------------------------------------------------------------------------------------------------------------------	-------	-----------

Group 5: Specialty Railroad Equipment; Asphalt Paver; Asphalt Reclaiming Machine; Line Grinder; Concrete Pumps; Drills with Self Contained Power Units; Boring Machine; Post Hole Digger; Auger; Pounder; Well Digger; Milling Machine (over 24" Mandrell)	37.51	24.05 + a
------------------------------------------------------------------------------------------------------------------------------------------------------------------------------------------------------------------------------------------------------------	-------	-----------

Group 5 continued: Side Boom; Combination Hoe and Loader; Directional Driller; Pile Testing Machine.	37.51	24.05 + a
------------------------------------------------------------------------------------------------------	-------	-----------

Group 6: Front End Loader (3 up to 7 cubic yards); Bulldozer (rough grade dozer).	37.20	24.05 + a
-----------------------------------------------------------------------------------	-------	-----------

Group 7: Asphalt roller, concrete saws and cutters (ride on types), vermeer concrete cutter, Stump Grinder; Scraper; Snooper; Skidder; Milling Machine (24" and under Mandrell).	36.86	24.05 + a
----------------------------------------------------------------------------------------------------------------------------------------------------------------------------------	-------	-----------

Group 8: Mechanic, grease truck operator, hydroblaster; barrier mover; power stone spreader; welding; work boat under 26 ft.; transfer machine.	36.46	24.05 + a
-------------------------------------------------------------------------------------------------------------------------------------------------	-------	-----------

As of: Friday, September 21, 2018

Project: Simsbury Public Library Phase I Lower Level Improvements

Group 9: Front end loader (under 3 cubic yards), skid steer loader regardless of attachments, (Bobcat or Similar): forklift, power chipper; landscape equipment (including Hydroseeder).	36.03	24.05 + a
------------------------------------------------------------------------------------------------------------------------------------------------------------------------------------------	-------	-----------

Group 10: Vibratory hammer; ice machine; diesel and air, hammer, etc.	33.99	24.05 + a
-----------------------------------------------------------------------	-------	-----------

Group 11: Conveyor, earth roller, power pavement breaker (whiphammer), robot demolition equipment.	33.99	24.05 + a
----------------------------------------------------------------------------------------------------	-------	-----------

Group 12: Wellpoint operator.	33.93	24.05 + a
-------------------------------	-------	-----------

Group 13: Compressor battery operator.	33.35	24.05 + a
----------------------------------------	-------	-----------

Group 14: Elevator operator; tow motor operator (solid tire no rough terrain).	32.21	24.05 + a
--------------------------------------------------------------------------------	-------	-----------

As of: Friday, September 21, 2018

Project: Simsbury Public Library Phase I Lower Level Improvements

Group 15: Generator Operator; Compressor Operator; Pump Operator; Welding Machine Operator; Heater Operator. 31.80 24.05 + a

Group 16: Maintenance Engineer/Oiler. 31.15 24.05 + a

Group 17: Portable asphalt plant operator; portable crusher plant operator; portable concrete plant operator. 35.46 24.05 + a

Group 18: Power safety boat; vacuum truck; zim mixer; sweeper; (Minimum for any job requiring a CDL license). 33.04 24.05 + a

-----PAINTERS (Including Drywall Finishing)-----

10a) Brush and Roller 33.62 21.05

As of: Friday, September 21, 2018

Project: Simsbury Public Library Phase I Lower Level Improvements

10b) Taping Only/Drywall Finishing	34.37	21.05
------------------------------------	-------	-------

10c) Paperhanger and Red Label	34.12	21.05
--------------------------------	-------	-------

10e) Blast and Spray	36.62	21.05
----------------------	-------	-------

11) Plumber (excluding HVAC pipe installation) (Trade License required: P-1,2,6,7,8,9 J-1,2,3,4 SP-1,2)	42.62	31.21
------------------------------------------------------------------------------------------------------------	-------	-------

12) Well Digger, Pile Testing Machine	37.26	24.05 + a
---------------------------------------	-------	-----------

13) Roofer (composition)	35.97	19.73
--------------------------	-------	-------

As of: Friday, September 21, 2018

Project: Simsbury Public Library Phase I Lower Level Improvements

14) Roofer (slate & tile)	36.47	19.73
---------------------------	-------	-------

15) Sheetmetal Worker (Trade License required for HVAC and Ductwork: SM-1,SM-2,SM-3,SM-4,SM-5,SM-6)	37.50	36.79
--------------------------------------------------------------------------------------------------------	-------	-------

16) Pipefitter (Including HVAC work) (Trade License required: S-1,2,3,4,5,6,7,8 B-1,2,3,4 D-1,2,3,4, G-1, G-2, G-8 & G-9)	42.62	31.21
---------------------------------------------------------------------------------------------------------------------------	-------	-------

-----TRUCK DRIVERS-----

17a) 2 Axle	29.13	23.33 + a
-------------	-------	-----------

17b) 3 Axle, 2 Axle Ready Mix	29.23	23.33 + a
-------------------------------	-------	-----------

As of: Friday, September 21, 2018

Project: Simsbury Public Library Phase I Lower Level Improvements

17c) 3 Axle Ready Mix	29.28	23.33 + a
-----------------------	-------	-----------

17d) 4 Axle, Heavy Duty Trailer up to 40 tons	29.33	23.33 + a
-----------------------------------------------	-------	-----------

17e) 4 Axle Ready Mix	29.38	23.33 + a
-----------------------	-------	-----------

17f) Heavy Duty Trailer (40 Tons and Over)	29.58	23.33 + a
--------------------------------------------	-------	-----------

17g) Specialized Earth Moving Equipment (Other Than Conventional Type on-the-Road Trucks and Semi-Trailers, Including Euclids)	29.38	23.33 + a
--------------------------------------------------------------------------------------------------------------------------------	-------	-----------

18) Sprinkler Fitter (Trade License required: F-1,2,3,4)	43.92	15.84 + a
----------------------------------------------------------	-------	-----------

As of: Friday, September 21, 2018

Project: Simsbury Public Library Phase I Lower Level Improvements

19) Theatrical Stage Journeyman	25.76	7.34
---------------------------------	-------	------

Project: Simsbury Public Library Phase I Lower Level Improvements

Welders: Rate for craft to which welding is incidental.

**Note: Hazardous waste removal work receives additional \$1.25 per hour for truck drivers.*

***Note: Hazardous waste premium \$3.00 per hour over classified rate*

ALL Cranes: When crane operator is operating equipment that requires a fully licensed crane operator to operate he receives an extra \$4.00 premium in addition to the hourly wage rate and benefit contributions:

1) Crane handling or erecting structural steel or stone; hoisting engineer (2 drums or over)

2) Cranes (100 ton rate capacity and over) Bauer Drill/Caisson

3) Cranes (under 100 ton rated capacity)

Crane with 150 ft. boom (including jib) - \$1.50 extra

Crane with 200 ft. boom (including jib) - \$2.50 extra

Crane with 250 ft. boom (including jib) - \$5.00 extra

Crane with 300 ft. boom (including jib) - \$7.00 extra

Crane with 400 ft. boom (including jib) - \$10.00 extra

All classifications that indicate a percentage of the fringe benefits must be calculated at the percentage rate times the "base hourly rate".

Apprentices duly registered under the Commissioner of Labor's regulations on "Work Training Standards for Apprenticeship and Training Programs" Section 31-51-d-1 to 12, are allowed to be paid the appropriate percentage of the prevailing journeymen hourly base and the full fringe benefit rate, providing the work site ratio shall not be less than one full-time journeyman instructing and supervising the work of each apprentice in a specific trade.

The Prevailing wage rates applicable to this project are subject to annual adjustments each July 1st for the duration of the project.

Each contractor shall pay the annual adjusted prevailing wage rate that is in effect each July 1st, as posted by the Department of Labor.

It is the contractor's responsibility to obtain the annual adjusted prevailing wage rate increases directly from the Department of Labor's website.

The annual adjustments will be posted on the Department of Labor's Web page: www.ct.gov/dol. For those without internet access, please contact the division listed below.

The Department of Labor will continue to issue the initial prevailing wage rate schedule to the Contracting Agency for the project.

All subsequent annual adjustments will be posted on our Web Site for contractor access.

Contracting Agencies are under no obligation pursuant to State labor law to pay any increase due to the annual adjustment provision.

As of: Friday, September 21, 2018

Project: Simsbury Public Library Phase I Lower Level Improvements

Effective October 1, 2005 - Public Act 05-50: any person performing the work of any mechanic, laborer, or worker shall be paid prevailing wage

All Person who perform work ON SITE must be paid prevailing wage for the appropriate mechanic, laborer, or worker classification.

All certified payrolls must list the hours worked and wages paid to All Persons who perform work ON SITE regardless of their ownership i.e.: (Owners, Corporate Officers, LLC Members, Independent Contractors, et. al)

Reporting and payment of wages is required regardless of any contractual relationship alleged to exist between the contractor and such person.

~~Unlisted classifications needed for work not included within the scope of the classifications listed may be added after award only as provided in the labor standards contract clause (29 CFR 5.5 (a) (1) (ii)).

Please direct any questions which you may have pertaining to classification of work and payment of prevailing wages to the Wage and Workplace Standards Division, telephone (860)263-6790.

As of: Friday, September 21, 2018

PERFORMANCE BOND

Bond Number _____

KNOW ALL MEN BY THESE PRESENTS:

That _____, as Principal, hereafter called Principal, and _____, as Surety, hereinafter called Surety are held and firmly bound unto the Town of Simsbury as Obligee, hereinafter called Owner, in the amount of _____ and _____/100 Dollars (\$_____), for the payment whereof Principal and Surety bind themselves, their heirs, executors, administrators, successors, and assigns, jointly and severally, by these presents.

WHEREAS, Principal has by written Agreement dated _____ entered into a Contract with the Owner for:

“SIMSBURY PUBLIC LIBRARY – Lower Level Improvements”

which Contract is by reference made a part hereof, and is hereinafter referred to as the Contract.

The Surety hereby waives notice of any alterations or extensions of time made by the Owner.

WHEREAS, Principal shall be, and declared by the Owner to be in default under the Contract, the Owner having performed the Owner’s obligations thereunder, the Surety shall promptly remedy the default, or shall promptly:

1. Complete the Contract in accordance with its terms and conditions; or,
2. Obtain a Bid or Bids for submission to the Owner for completing the Contract in accordance with its terms and conditions, and upon determination by the Owner and Surety of the lowest qualified responsible Bidder, arrange for a Contract between the Bidder and the Owner, and make available as Work progresses (even though there should be a default or a succession of defaults under Contract or Contracts of completion arranged under this paragraph) sufficient funds to pay the cost of completion of the Contract.

Any suit brought under this Bond must be instituted before the expiration of three wo (3) years from the date on which final payment under this Contract is rendered.

This Bond is issued simultaneously with another Bond in favor of the Town of Simsbury conditioned for full payment of Labor and Materials.

No right of action shall accrue on this Bond to or for the use of any person or corporation other than the Owner named herein or the executors, administrators, or successors of the Owner.

Signed and sealed this _____ day of _____, 20_____.

(Seal of Principal)

(Principal)

In the Presence of:

_____ By: _____
(witness)

(witness)

(Seal of Surety)

(Surety)

_____ By: _____
(witness)

(witness)

(Power of Attorney for person signing for surety company must be attached to the Bond)

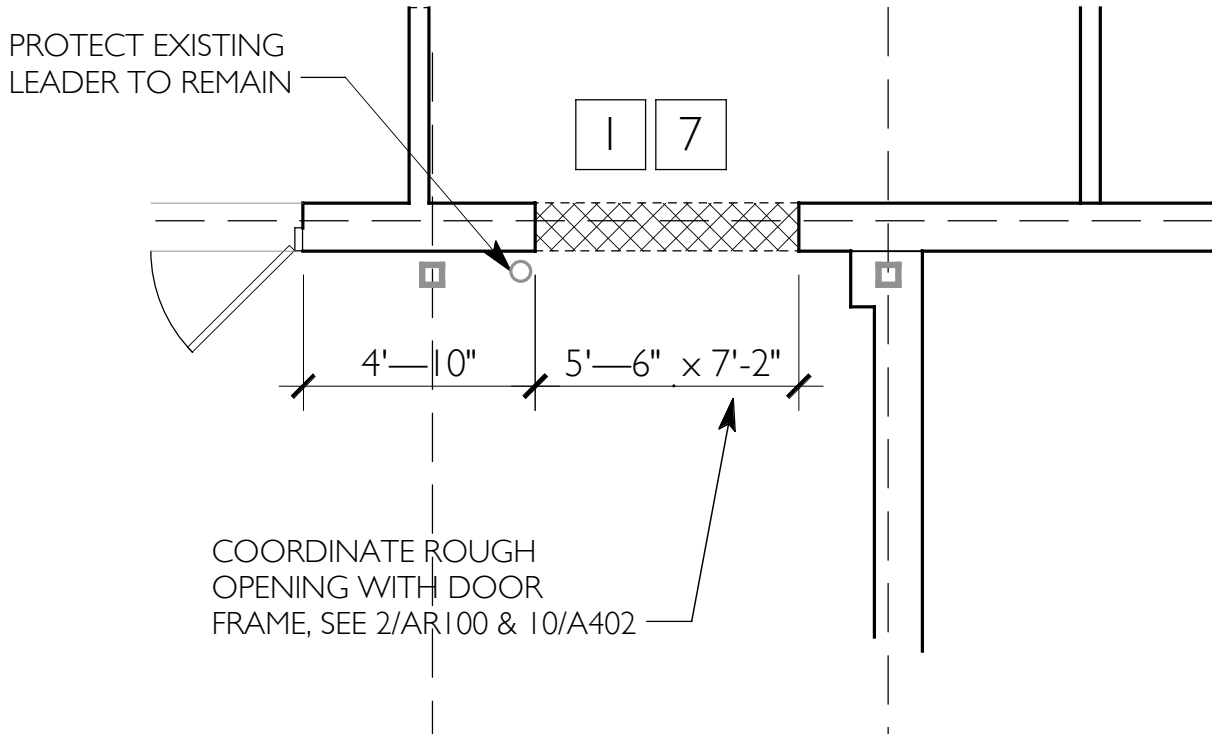

1
AR100

LOWER FLOOR PLAN - DEMOLITION & REMOVALS

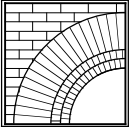
<p>Addendum # 1</p>	<p>Lower Level Improvements for the SIMSBURY PUBLIC LIBRARY</p> <hr/> <p>BRMA Project No. 16.39.28</p>	<p>AR100 LOWER LEVEL PLAN - DEMOLITION + REMOVALS</p>	
 <p>BUTLER ROWLAND MAYS ARCHITECTS, LLP</p>		<p>Scale: 1/4" = 1'-0"</p>	<p>Sketch SK- AR100.1</p>
		<p>Date: 17 OCTOBER 2018</p>	

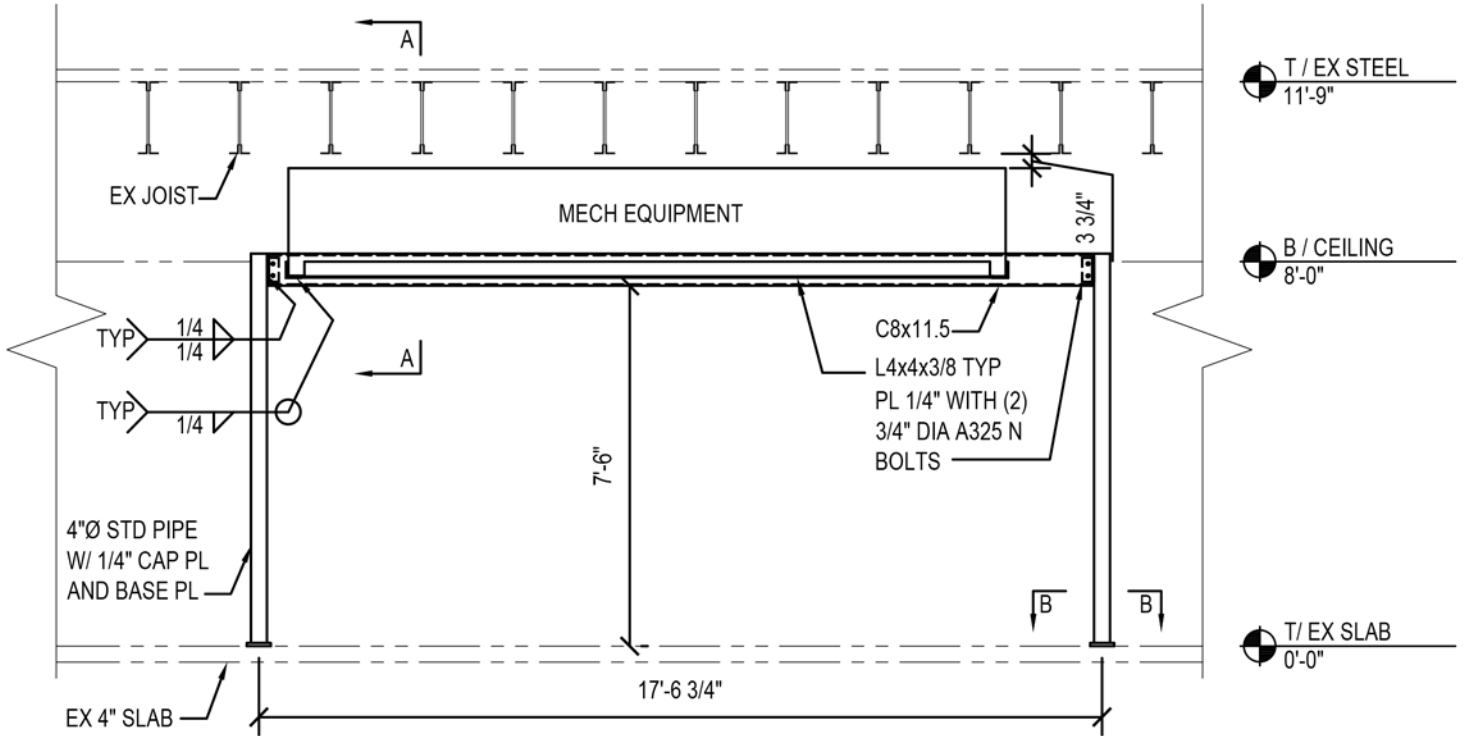

NOTES:

1. DUNNAGE BRACING NOT SHOWN FOR CLARITY. SEE DETAIL 3/S-1.
2. COORDINATE WITH MECHANICAL EQUIPMENT SPECS PRIOR TO STEEL FABRICATION FOR EXACT EQUIPMENT SUPPORT DIMENSIONS.
3. FIELD VERIFY EXISTING CONDITIONS BEFORE STEEL COLUMN ERECTION.

2 STRUCTURAL PLATFORM

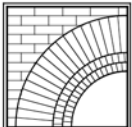
Addendum # 1	Lower Level Improvements for the SIMSBURY PUBLIC LIBRARY	A100 LOWER LEVEL PLAN NEW WORK + NOTES	
 <p>BUTLER ROWLAND MAYS ARCHITECTS, LLP</p>	BRMA Project No. 16.39.28	Scale: 1/4" = 1'-0"	Sketch SK- A100.1
		Date: 17 OCTOBER 2018	

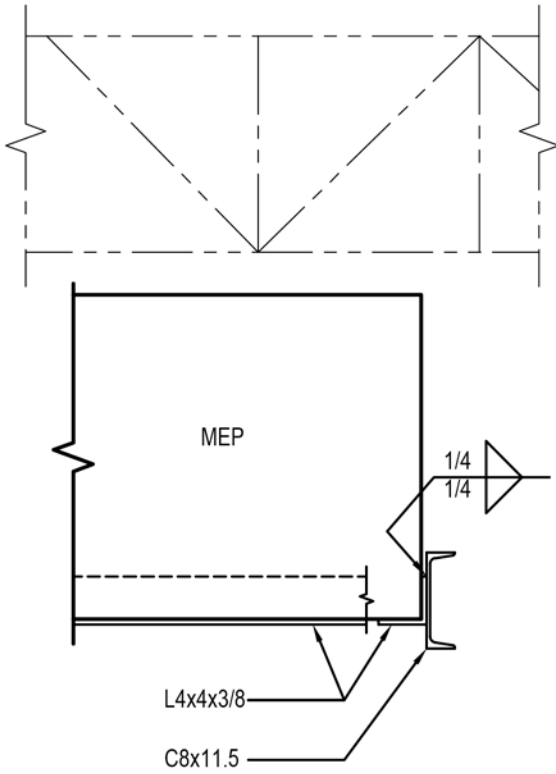

SECTION A-A

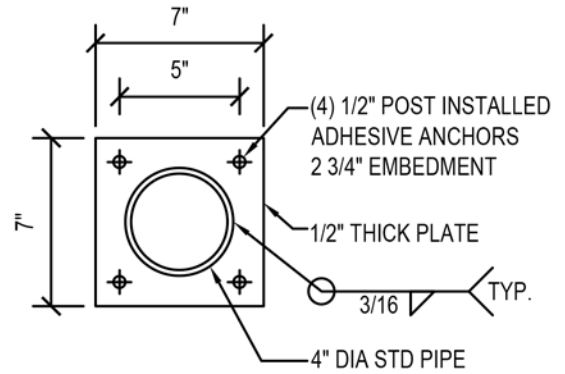

SECTION B-B

2
A100 STRUCTURAL PLATFORM

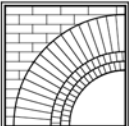
<p>Addendum # 1</p>	<p>Lower Level Improvements for the SIMSBURY PUBLIC LIBRARY</p>	<p>A100 LOWER LEVEL PLAN NEW WORK + NOTES</p>	
 <p>BUTLER ROWLAND MAYS ARCHITECTS, LLP</p>	<p>BRMA Project No. 16.39.28</p>	<p>Scale: 1/4" = 1'-0"</p>	<p>Sketch SK- A100.2</p>
		<p>Date: 17 OCTOBER 2018</p>	

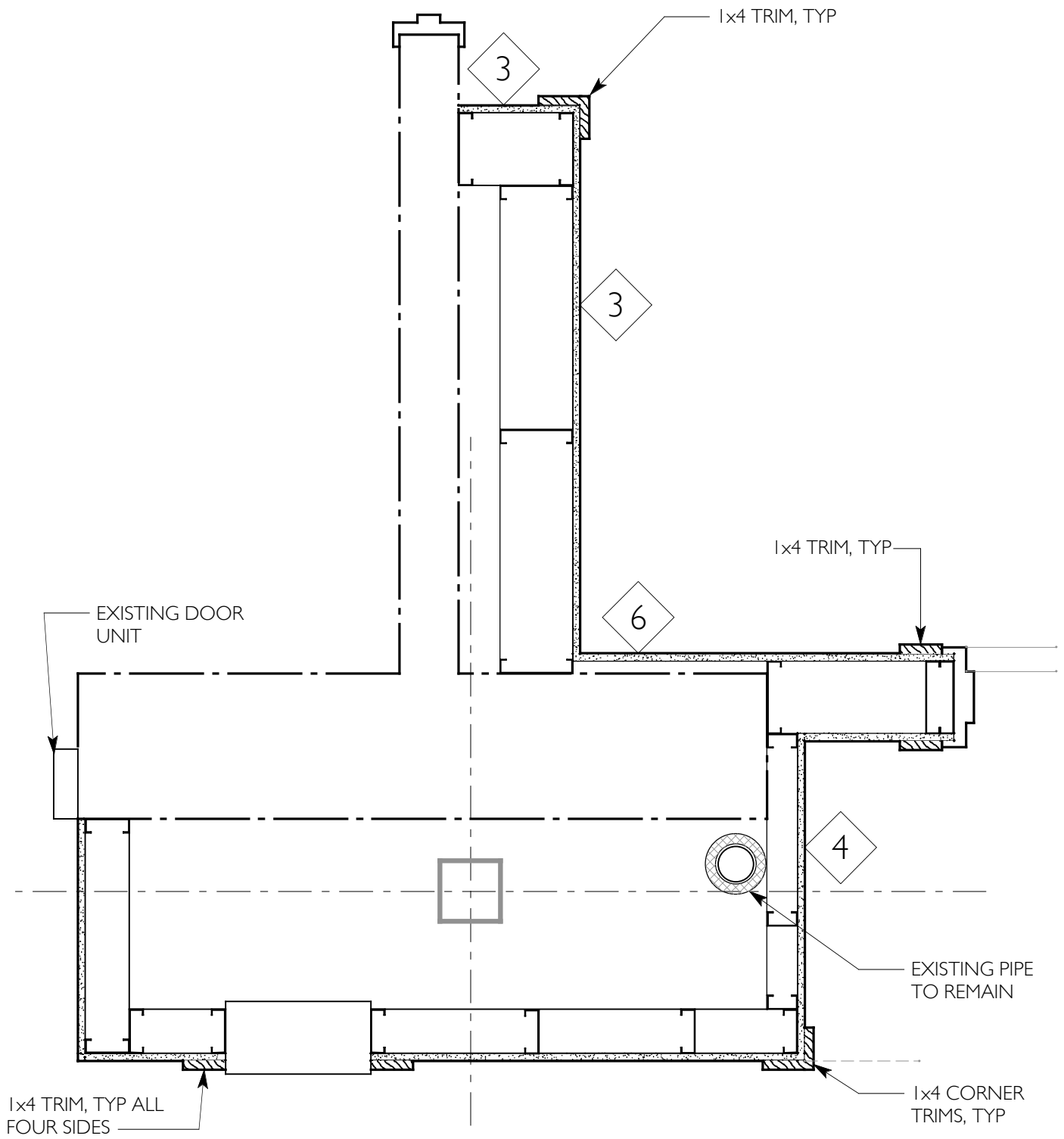

10 PLAN DETAIL @ NEW DOOR
A402

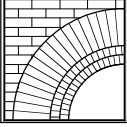
Addendum # 1	Lower Level Improvements for the SIMSBURY PUBLIC LIBRARY	A402 DETAILS	
 <p>BUTLER ROWLAND MAYS ARCHITECTS, LLP</p>	<hr/> BRMA Project No. 16.39.28	Scale: 1/4" = 1'-0"	Sketch SK- A402.1
		Date: 17 OCTOBER 2018	

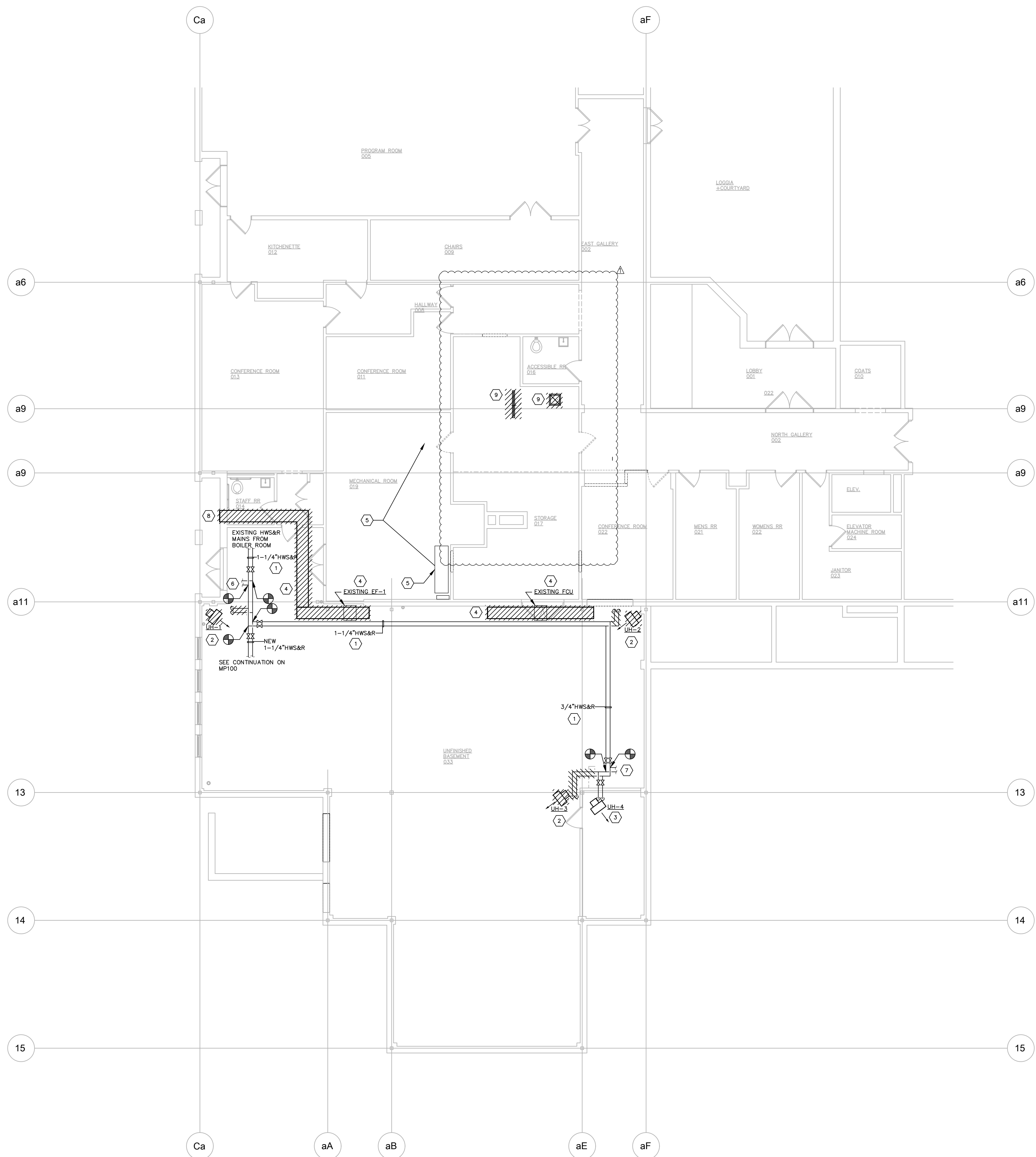

- ### DEMOLITION KEY NOTES
- 1 ALL EXISTING HEATING HOT WATER MAINS TO REMAIN.
 - 2 EXISTING UH-1, UH-2, & UH-3 TO BE REMOVED AND THE BRANCH HWS&R PIPING TO BE REMOVED & CAPPED AT THE MAINS.
 - 3 EXISTING UH-4 & ASSOCIATED PIPING IN UTILITY ROOM TO REMAIN AS IS.
 - 4 EXISTING EF-1, FAN COIL UNIT (FCU) SERVING THE ROOM, AND THE ASSOCIATED DUCTWORK TO BE REMOVED. THE BRANCH HWS&R PIPING FOR THE FCU TO BE REMOVED & CAPPED AT THE MAINS.
 - 5 EXISTING COMPRESSED AIR SYSTEM (COMPRESSOR, ASSOCIATED PIPING, PNEUMATIC CONTROLS, ETC.) TO BE RELOCATED AND REUSED WITHIN THE BOILER ROOM (MECHANICAL ROOM #019). SEE M100 FOR THE SYSTEM NEW LOCATION.
 - 6 NEW 3/4" HWS&R TO/FROM THE NEW CUH-1. SEE MP100 FOR PIPING CONTINUATION AND CUH-1 LOCATION.
 - 7 NEW 3/4" HWS&R TO/FROM UH-1 (NEW). SEE MP100 FOR PIPING CONTINUATION AND UH-1 (NEW) LOCATION.
 - 8 AFTER THE REMOVAL OF THE EXISTING OA DUCT AS INDICATED, CAP AND INSULATE (PER ARCHITECTURAL SPECIFICATION) THE INTERIOR SIDE OF EXISTING LOUVER AT THE EXTERIOR WALL. MAKE SURE THAT IT IS AIR TIGHT.
 - 9 DEMOLISH THE EXISTING SUPPLY AIR LINEAR DIFFUSER AND THE EXISTING RETURN AIR REGISTER AT THE LOCATIONS SHOWN. THE EXISTING CONNECTING DUCTS TO REMAIN AND BE RECONNECTED WITH NEW DIFFUSER AND REGISTER PER DRAWING M100.

- ### DEMOLITION NOTES
1. CONTRACTOR SHALL VISIT THE SITE AND BECOME FAMILIAR WITH THE EXISTING SYSTEM AND CONDITIONS IN AREAS OF RENOVATION.
 2. ALL EXISTING PIPING AND EQUIPMENT SHOWN HAS BEEN TAKEN FROM THE BEST AVAILABLE EXISTING INFORMATION. THE DRAWINGS ARE DIAGRAMMATIC AND ALL PIPING AND DEVICES MAY NOT BE SHOWN. ENGINEER MAKES NO GUARENTEE TO THE ACCURACY OF THE EXISTING CONDITIONS.
 3. ALL PIPING TO BE REMOVED SHALL BE REMOVED COMPLETELY OR CAPPED AS SHOWN OR NOTED OTHERWISE WITHOUT LEAVING ANY DEAD ENDED PIPING OR ABANDONED PIPING.
 4. THE EXISTING SYSTEM SHALL REMAIN ACTIVE DURING RENOVATION. CONTRACTOR SHALL COORDINATE DAILY SHUT-DOWNS AS REQUIRED FOR NEW WORK WITH THE OWNER.
 5. ALL SERVICE INTERRUPTIONS SHALL BE COORDINATED WITH THE OWNER A MINIMUM OF 3 DAYS IN ADVANCE.
 6. CONTRACTOR SHALL ALSO REVIEW THE ARCHITECTURAL DEMOLITION DRAWINGS AS PART OF THIS CONTRACT FOR ADDITIONAL INFORMATION AND REQUIREMENTS.

ADDENDUM #1: 17-OCT-2018
 ISSUED FOR BIDDING: 3-OCT-2018
 ISSUES and REVISIONS

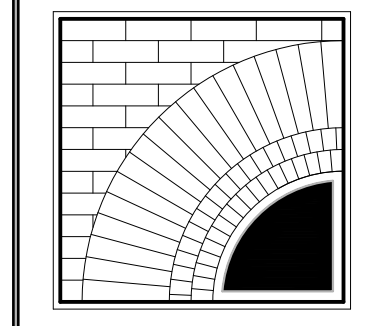

**BUTLER
 ROWLAND
 MAYS**
 ARCHITECTS, LLP
 57 West High Street
 Ballston Spa
 New York 12020
 PH: 518-885-1255
 FAX: 518-885-1266
 www.brmaarchitects.com



CLE
 Consulting, Engineering Services, Inc.
 811 Middle Street
 Middletown, CT 06457
 Tel: 860-632-1682
 Fax: 860-632-1708
 CES *2018114.09

CONSULTANT
 Lower Level Interior
 Improvements
 for the
**Simsbury
 Public
 Library**
 725 Hopmeadow St.
 Simsbury, CT

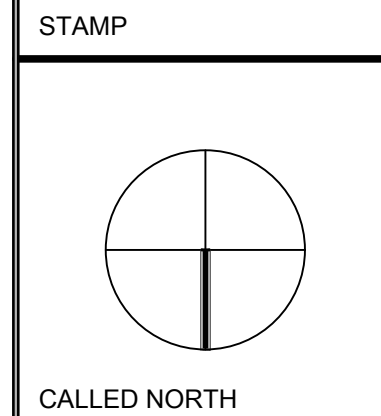

DWN BY: PDP
 SCALE: 1/8" = 1'-0"
 JOB NO.: 2018114.00
 DATE: 03.10.2018

**MECHANICAL
 LOWER FLOOR
 PLAN - DEMO &
 NEW PIPING
 WORK**

TITLE
MD100
 DWG. NO.

1 MECHANICAL LOWER FLOOR PLAN - DEMOLITION & REMOVALS
 MD100 SCALE: 1/8" = 1'-0"



THIS DRAWING AND THE CONTENTS THEREOF ARE THE SOLE AND COPYRIGHTED PROPERTY OF BUTLER ROWLAND MAYS ARCHITECTS, LLP. NO PART OF THIS DRAWING OR ANY INFORMATION HEREON MAY BE REPRODUCED OR TRANSMITTED IN ANY FORM OR BY ANY MEANS, ELECTRONIC OR MECHANICAL, INCLUDING PHOTOCOPYING, RECORDING, OR BY ANY INFORMATION STORAGE AND RETRIEVAL SYSTEM, WITHOUT THE EXPRESS WRITTEN CONSENT OF BUTLER ROWLAND MAYS ARCHITECTS, LLP.

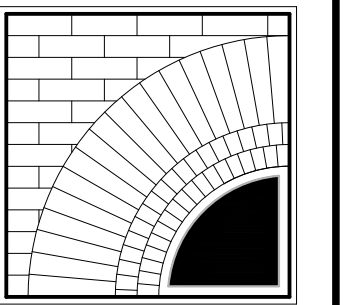

**BUTLER
ROWLAND
MAYS**

ARCHITECTS, LLP

57 West High Street
Ballston Spa
New York 12020

PH: 518-885-1255
FAX: 518-885-1266
www.brmarchitects.com



111 Middle Street
Middletown, CT 06457
Tel: 860-632-1682
Fax: 860-532-1708
CES-2018114.00

CONSULTANT

Lower Level Interior
Improvements
for the
**Simsbury
Public
Library**

725 Hopmeadow St.
Simsbury, CT

STAMP

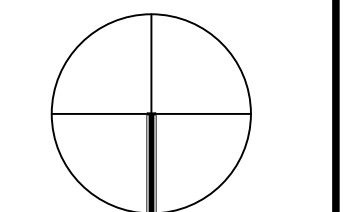

CALLED NORTH

DWN BY: PDP
SCALE: 1/8" = 1'-0"
JOB NO.: 2018114.00
DATE: 03.10.2018

MECHANICAL
LOWER FLOOR
PLAN - NEW

TITLE

M100
DWG. NO.

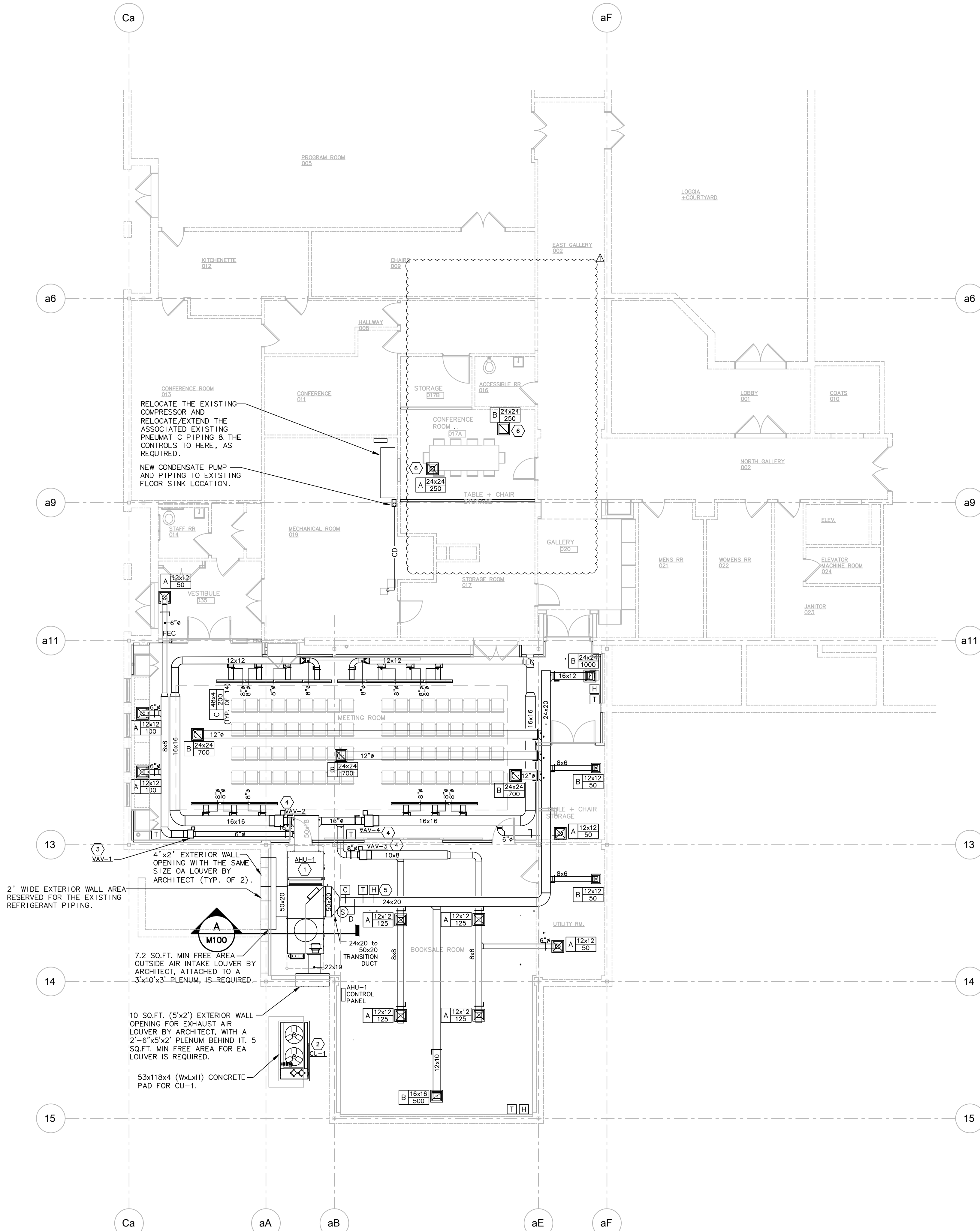

- ### KEY NOTES
1. BOTTOM OF AHU-1 TO BE 7'-6" AFF OR HIGHER IF FIELD CONDITIONS ALLOW. REFERENCE MANUFACTURER'S INSTALLATION INSTRUCTIONS. SEE DETAIL 4/M300 FOR MORE INSTALLATION INFO.
 2. INSTALL A 53x118x4 (WxLxH) CONCRETE PAD AT GRADE LEVEL FOR CU-1 INSTALLATION. VERIFY ACTUAL EQUIPMENT DIMENSIONS BEFORE INSTALLING THE PAD AND FOLLOW MANUFACTURER'S INSTRUCTIONS FOR THE UNIT INSTALLATION.
 3. INSTALL VAV-1 AND ASSOCIATED DUCTWORK AND HWS&R PIPING FOR THE REHEAT COIL IN THE VAV BOX ABOVE THE DROP CEILING. VAV-1 IS TO BE CONTROLLED BY ITS WALL MOUNT ROOM THERMOSTAT. SEE THIS DRAWING FOR LOCATION OF THE THERMOSTAT. REFERENCE ARCHITECTURAL DRAWINGS FOR ACTUAL DROP CEILING HEIGHT IN THE ROOM.
 4. INSTALL VAV-2, VAV-3, & VAV-4 AND ASSOCIATED DUCTWORK ABOVE THE DROP CEILING. VAV-2, VAV-3, & VAV-4 ARE TO BE CONTROLLED BY THEIR CORRESPONDING WALL MOUNT ROOM THERMOSTAT AND HUMIDISTAT. SEE THIS DRAWING FOR LOCATIONS OF THE THERMOSTATS & HUMIDISTATS. REFERENCE ARCHITECTURAL DRAWINGS FOR ACTUAL DROP CEILING HEIGHT IN THE ROOM.
 5. INSTALL DUCT MOUNT SMOKE DETECTOR, CO2 SENSOR, AND TEMPERATURE & HUMIDITY SENSORS AT THE MAIN RETURN AIR DUCT GOING INTO AHU-1 AS INDICATED.
 6. INSTALL NEW SUPPLY AIR DIFFUSER AND RECONNECT IT TO THE EXISTING EVAV-5 DISCHARGE DUCT. INSTALL NEW RETURN AIR REGISTER AND DISCONNECT IT WITH THE EXISTING 20x14 DUCT MAIN.

- ### NEW WORK NOTES
1. CONTRACTOR SHALL VISIT THE SITE AND FIELD VERIFY CONDITIONS IN AREAS OF RENOVATION BEFORE ORDERING EQUIPMENT AND START CONSTRUCTION.
 2. ALL EXISTING PIPING AND EQUIPMENT SHOWN HAS BEEN TAKEN FROM THE BEST AVAILABLE EXISTING INFORMATION. THE DRAWINGS ARE DIAGRAMMATIC AND ALL PIPING AND DEVICES MAY NOT BE SHOWN.
 3. EXISTING SYSTEMS OUTSIDE OF THE WORK AREAS SHALL REMAIN ACTIVE DURING RENOVATION. CONTRACTOR SHALL COORDINATE DAILY SHUT-DOWNS AS REQUIRED FOR NEW WORK WITH THE OWNER.
 4. ALL SERVICE INTERRUPTIONS SHALL BE COORDINATED WITH THE OWNER A MINIMUM OF 3 DAYS IN ADVANCE.
 5. CONTRACTOR SHALL ALSO REVIEW THE ARCHITECTURAL AND ALL OTHER TRADES' DRAWINGS AS PART OF THIS CONTRACT FOR ADDITIONAL INFORMATION AND REQUIREMENTS.
 6. INSTALL ALL HORIZONTAL DUCTWORK AT ABOVE ROOM DROP CEILING LEVEL.

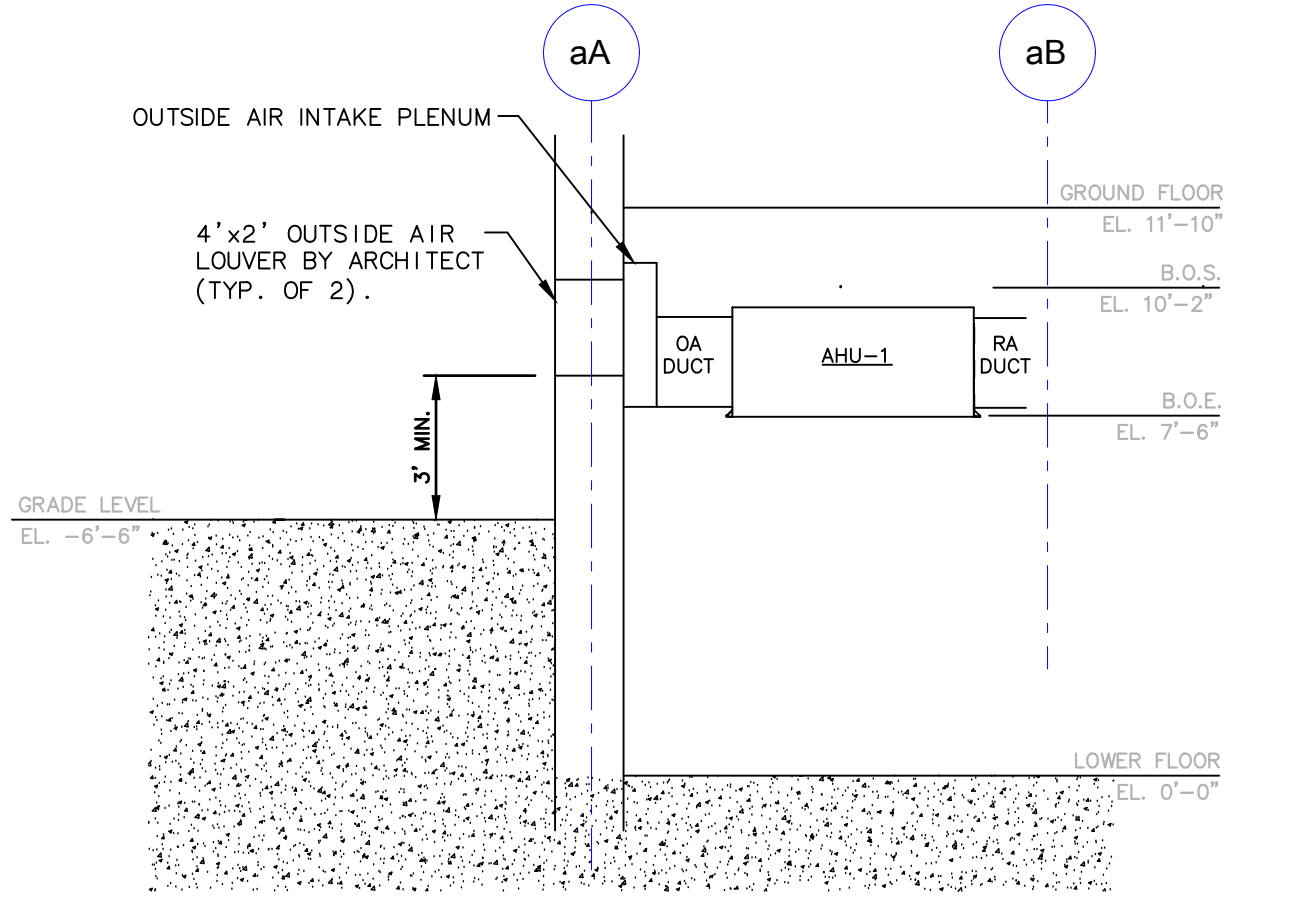

A SECTION A-A
1/4" = 1'-0"

M100 MECHANICAL LOWER FLOOR PLAN - NEW WORK
SCALE: 1/8" = 1'-0"



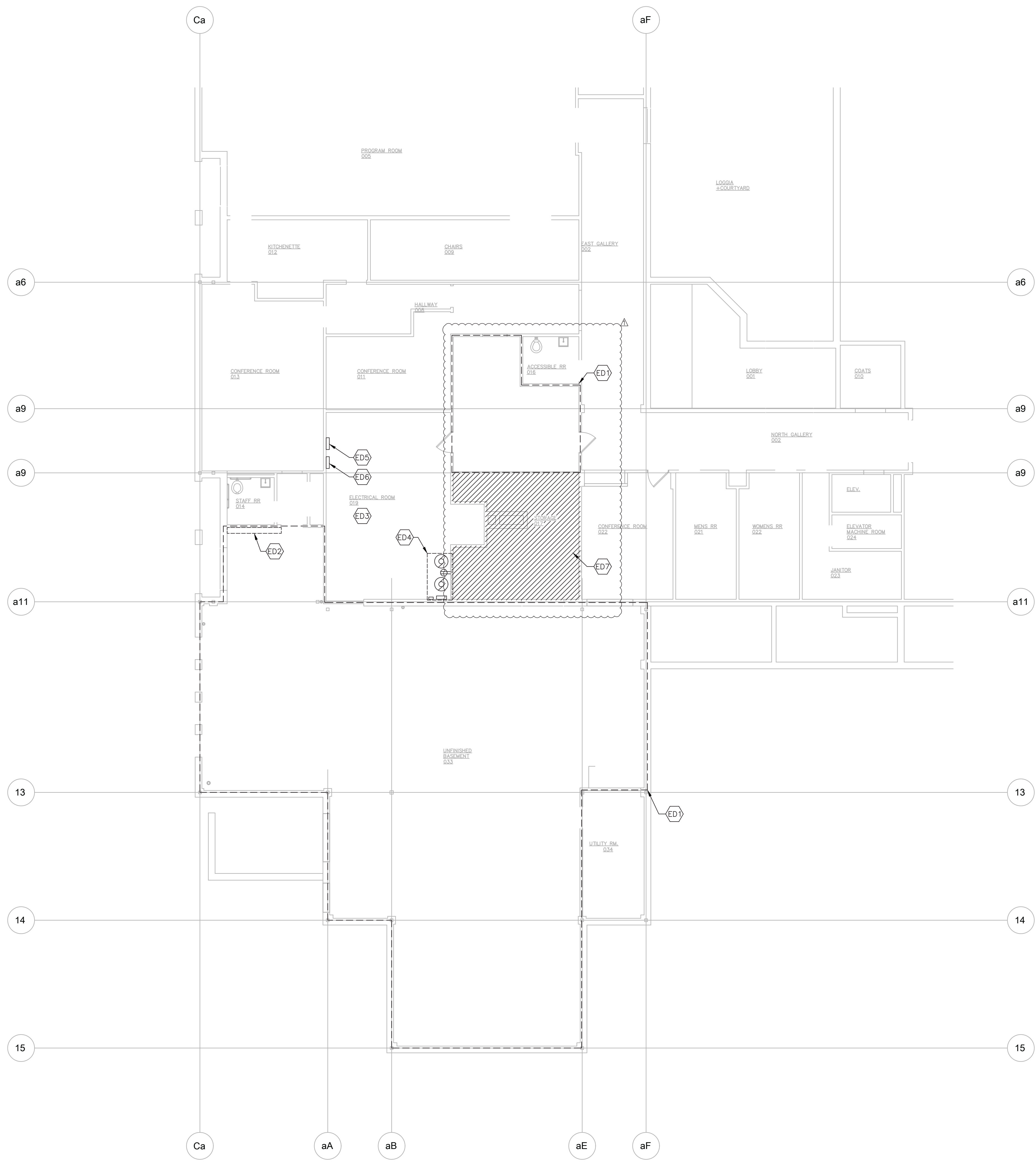

GENERAL NOTES - ELECTRICAL DEMOLITION

- ALL ELECTRICAL DEVICES WITHIN THE AREA OF DEMOLITION (INDICATED ON PLANS) SHALL BE REMOVED UNLESS NOTED OTHERWISE, INCLUDING BUT NOT LIMITED TO: RECEPTACLES, LIGHT FIXTURES, LIGHTING CONTROLS, FIRE ALARM DEVICES, MECHANICAL CONNECTIONS, ETC. REMOVAL SHALL BE COMPLETE INCLUDING BOXES, BRACKETS, HANGERS, AND BRANCH CIRCUIT WIRING BACK TO SOURCE PANELBOARD OR LAST ACTIVE DEVICE TO REMAIN (EXCEPT WHERE NOTED).
- CONTRACTOR SHALL BE RESPONSIBLE FOR DISPOSAL OF ITEMS TO BE REMOVED IN A SAFE, LEGAL AND RESPONSIBLE MANNER.
- CONTRACTOR SHALL BE RESPONSIBLE FOR STORAGE AND HANDLING OF EXISTING TO BE RELOCATED EQUIPMENT.
- CONTRACTOR SHALL MODIFY EXISTING CIRCUITS, WHEN EXISTING DEVICES ARE REMOVED, AS REQUIRED TO MAINTAIN CIRCUIT CONTINUITY.
- THIS PLAN IS DIAGRAMMATIC AND NOT INTENDED TO DEPICT THE ENTIRE SCOPE OF ELECTRICAL DEMOLITION. ADDITIONAL DEMOLITION AND MODIFICATION WORK NOT SHOWN SHOULD BE ANTICIPATED.
- THIS PROJECT COMPRISES ALTERATIONS AND RENOVATIONS TO THE EXISTING BUILDING. THE EXISTING BUILDING IS CURRENTLY OCCUPIED AND THE PROJECT WILL PROCEED IN A MANNER WHICH WILL MINIMIZE ANY INCONVENIENCE TO THE BUILDING OCCUPANTS.
- PRIOR TO SUBMITTING BID, VISIT SITE AND IDENTIFY EXISTING CONDITIONS AND DIFFICULTIES THAT WILL AFFECT WORK TO BE PERFORMED. NO COMPENSATION WILL BE GRANTED FOR ADDITIONAL WORK CAUSED BY UNFAMILIARITY WITH SITE CONDITIONS THAT ARE VISIBLE OR READILY IDENTIFIED BY EXPERIENCED OBSERVERS. INCLUDE IN THE BID ALL DEMOLITION WORK REQUIRED.
- REFER TO DRAWING E000 FOR SYMBOLS, LEGENDS, AND ABBREVIATIONS.
- EXISTING FIRE ALARM SYSTEM SHALL BE MODIFIED IN AREA OF WORK AND BE MAINTAINED OUTSIDE OF AREA OF WORK. MAINTAIN OPERATION OF THE EXISTING FIRE ALARM SYSTEM DURING DEMOLITION. DEVICES ARE TO BE REMOVED BACK TO NEXT DEVICE OUTSIDE OF THE AREA OF WORK. EXTEND CIRCUITS WITH WIRING TO MATCH EXISTING CLASS AND STYLE AS REQUIRED TO MAINTAIN CONTINUITY OF CIRCUITS UPSTREAM AND DOWNSTREAM OF THE WORK AFFECTED BY DEMOLITION. PROTECT EXISTING DEVICES DURING CONSTRUCTION. TAKE DEVICE OFF-LINE IF NECESSARY. COORDINATE BYPASSING AND REACTIVATION OF THE DEVICE WITH THE OWNER.
- DEMOLITION IS TO BE PERFORMED IN A SELECTIVE FASHION AND PERFORMED TO MAINTAIN EXISTING SYSTEMS IN AREAS REMAINING OPERATIONAL. IT IS THE CONTRACTOR'S RESPONSIBILITY TO COORDINATE DISRUPTION OF SYSTEMS OR CIRCUITS AND TO INVESTIGATE ALL CIRCUITING AND DEVICES SCHEDULED FOR REMOVAL. PROVIDE TEMPORARY MEASURES TO MAINTAIN EXISTING SYSTEMS AND CIRCUITS AS REQUIRED.

KEY NOTES - ELECTRICAL DEMOLITION

- ED1 AREA OF DEMOLITION; UNLESS OTHERWISE NOTED, ALL BRANCH CIRCUIT WIRING AND LOW VOLTAGE WIRING SHALL BE REMOVED BACK TO THE SOURCE AND ALL TELECOMMUNICATIONS WIRING SHALL BE REMOVED BACK TO THE TELECOMMUNICATIONS TERMINATION.
- ED2 EXISTING TELECOMMUNICATIONS DEMARCATION POINT: ALL EQUIPMENT SHALL BE EXISTING TO REMAIN WITH EXCEPTION OF EXISTING DUAL-HEAD EMERGENCY LIGHT. RELOCATE EQUIPMENT AS REQUIRED TO FIT WITHIN NEW I.T. CLOSET. REFER TO EP100 FOR ADDITIONAL INFORMATION.
- ED3 UNLESS OTHERWISE NOTED, ALL ELECTRICAL EQUIPMENT, LIGHTING, FIRE ALARM DEVICES, ETC. LOCATED IN ELECTRICAL ROOM 019 SHALL BE EXISTING TO REMAIN.
- ED4 EXISTING AIR COMPRESSOR, CONTROL PANEL AND DISCONNECT SWITCH SHALL BE RELOCATED. EXISTING DUPLEX RECEPTACLE LOCATED BEHIND AIR COMPRESSOR SHALL BE REMOVED TO ACCOMMODATE NEW DOOR. REFER TO SHEET EP100 FOR ADDITIONAL INFORMATION AND NEW LOCATION OF EQUIPMENT.
- ED5 APPROXIMATE LOCATION OF EXISTING TO REMAIN PANELBOARD "L3".
- ED6 APPROXIMATE LOCATION OF EXISTING TO REMAIN PANELBOARD "PPA".
- ED7 ALL DEVICES (LIGHTING, RECEPTACLES, FIRE ALARM, ETC.) WITHIN THIS REGION SHALL BE EXISTING TO REMAIN. REFER TO NEW WORK PLANS FOR ADDITIONAL INFORMATION.

1 ELECTRICAL LOWER FLOOR PLAN - DEMOLITION & REMOVALS
ED100 SCALE: 1/8" = 1'-0"



ADDENDUM #1: 17-OCT-2018
ISSUED FOR BIDDING: 3-OCT-2018
ISSUES and REVISIONS

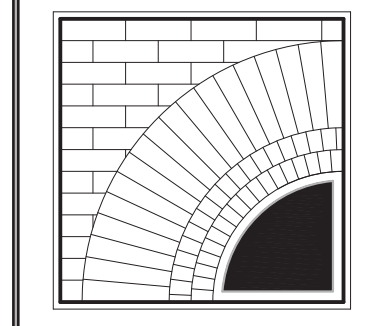

**BUTLER
ROWLAND
MAYS**
ARCHITECTS, LLP
57 West High Street
Ballston Spa
New York 12020
PH: 518-885-1255
FAX: 518-885-1266
www.brmarchitects.com



1811 Middle Street
Middletown, CT 06457
Tel: 860-632-1082
Fax: 860-632-1708
CES *2018114.00

CONSULTANT

Lower Level Interior
Improvements
for the
**Simsbury
Public
Library**

725 Hopmeadow St.
Simsbury, CT

STAMP

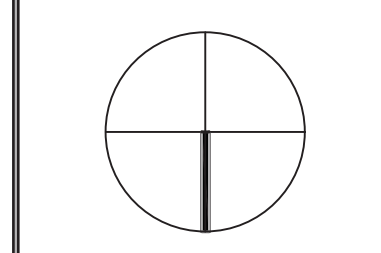

CALLED NORTH

DWN BY: MFC
SCALE: 1/8" = 1'-0"
JOB NO.: 2018114.00
DATE: 03.10.2018

**ELECTRICAL
LOWER FLOOR
PLAN - DEMO**

TITLE

ED100
DWG. NO.

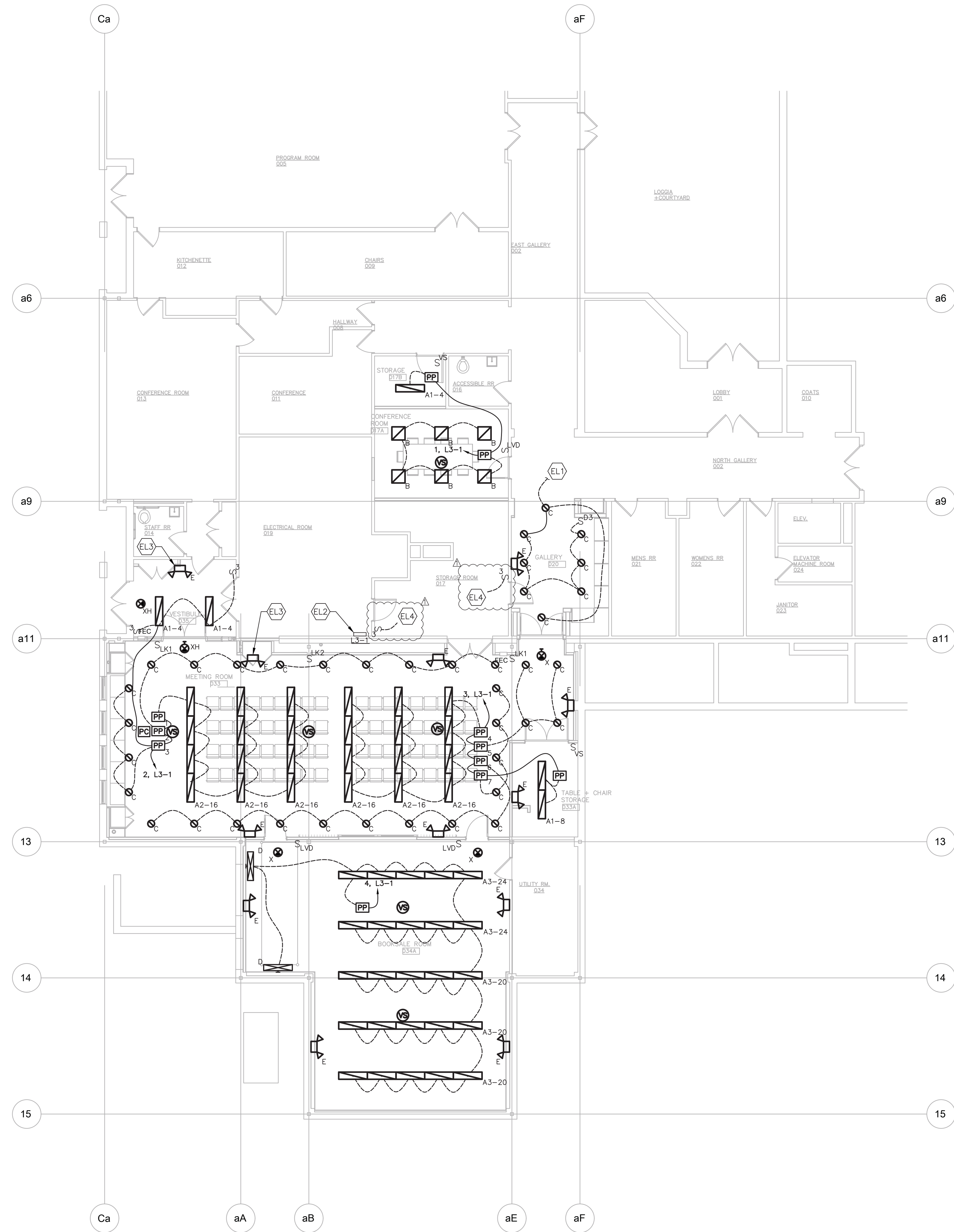

GENERAL NOTES - ELECTRICAL LIGHTING

1. ALL CIRCUITS SHALL BE 2/12, #12G, 3/4" C TO NEW 20A/1P CIRCUIT BREAKER IN PANEL INDICATED, UNLESS OTHERWISE NOTED.
2. ALL BRANCH 120V, 20A BRANCH CIRCUITS EXCEEDING 150' IN LENGTH SHALL BE 2#10, #10G, 3/4" C, UNLESS OTHERWISE NOTED.
3. ALL DEVICES SHALL BE LABELED WITH SOURCE PANEL AND CIRCUIT NUMBER(S).
4. REFER TO ARCHITECTS REFLECTED CEILING PLAN FOR EXACT LOCATION OF CEILING MOUNTED ELECTRICAL DEVICES.
5. REFER TO DRAWING E000 FOR ELECTRICAL SYMBOLS, LEGENDS, AND ABBREVIATIONS.
6. PROVIDE FIRE STOPPING AND SMOKE BARRIER SEALING OF ALL PENETRATIONS THROUGH FIRE WALLS OR SMOKE BARRIERS AS REQUIRED. REFER TO ARCHITECTURAL FLOOR PLANS AND CODE SHEETS FOR WALLS.
7. ALL RECEPTACLES LOCATED WITHIN 6' FROM SINKS SHALL BE GFCI TYPE.
8. EXIT SIGNS AND EMERGENCY LIGHTS SHALL BE WIRED TO LINE SIDE OF LOCAL LIGHTING BRANCH CIRCUIT, AHEAD OF ALL SWITCHING DEVICES.

KEY NOTES - ELECTRICAL LIGHTING

(EL1) CONNECT TO THE EXISTING LIGHTING CIRCUIT IN NORTH GALLERY 002 WITH 2/12, #12G, 3/4" C. CONTRACTOR SHALL FIELD VERIFY CONNECTIONS. WIRE AHEAD OF ALL SWITCHES.

(EL2) NEW PANELBOARD "L3-1". REFER TO EP100 FOR ADDITIONAL INFORMATION.

(EL3) MOUNT ABOVE CLOSET DOOR.

(EL4) WIRE NEW SWITCH TO EXISTING LIGHTING CIRCUIT WITHIN ROOM. PROVIDE 2/12, #12G, 3/4" C.

1 ELECTRICAL LIGHTING LOWER FLOOR PLAN - NEW WORK
EL100 SCALE: 1/8" = 1'-0"



ADDENDUM #1: 17-OCT-2018
ISSUED FOR BIDDING: 3-OCT-2018
ISSUES and REVISIONS

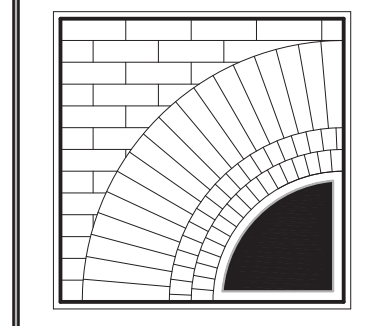

**BUTLER
ROWLAND
MAYS**
ARCHITECTS, LLP
57 West High Street
Ballston Spa
New York 12020
PH: 518-885-1255
FAX: 518-885-1266
www.brmarchitects.com

CLS
Consulting Engineering Services, Inc.
111 Middle Street
Middletown, CT 06457
Tel: 860-632-1682
Fax: 860-632-1708
CES #2018114109

CONSULTANT

Lower Level Interior
Improvements
for the
**Simsbury
Public
Library**

725 Hopmeadow St.
Simsbury, CT

STAMP

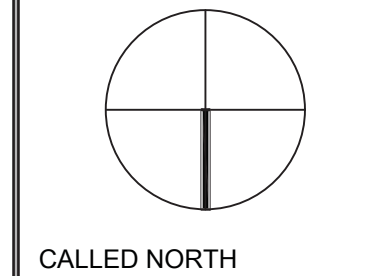

DWN BY: MFC
SCALE: 1/8" = 1'-0"
JOB NO.: 2018114.00
DATE: 03.10.2018

**ELECTRICAL
LIGHTING
LOWER FLOOR
PLAN - NEW**

TITLE

EL100
DWG. NO.

From: Mike Garneau [mgarneau@wjmountford.com]
Sent: Thursday, October 11, 2018 3:28 PM
To: Shea Jeff
Cc: Mike Garneau
Subject: Simsbury Library RFI 01

Hello Jerome, I have a few questions for the bid:

- 1) Does all drywall go up to the deck? Wall types do not mention this.
All new partitions to be installed to underside of existing deck, per item #10 Addendum #1.
- 2) Drawing M100 shows a 3rd louver on the wall at 14 line, drawings AR100 & A100 do not show this louver. Please provide lintel requirements.
Refer to A100 for lintel requirements, M100 louver locations to be revised per Addendum #2.
- 3) Please provide a detail for the steel galvanized areaway.
Provide and install new galvanized steel areaway by Admiral Steel or equal, Economy Straight ES-5918 24" height with steel grate cover, per item #13 Addendum #1.
- 4) Please provide more details for the structural platform. Is there steel decking, concrete slab, mesh, welding details, pour stop, etc.
See Sketches SK-A100.1 and SK-A100.2, per item #15 and #16 Addendum #1.
- 5) Is the intent to cut the concrete wall full height to the deck or just to the frame head for new door 048?
See Sketch SK-AR100.1 per item #7 Addendum #1.
- 6) There are no plumbing drawings, see demo note 4, 14 on AR100 & note 10 on A100.
See fixture specifications item #14 Addendum #1.

Thanks,

Mike Garneau
Estimator
W. J. Mountford Co.
P 860-291-9448 x 124
F 860-289-6382
mgarneau@wjmountford.com

W.J. Mountford Co. is an Affirmative Action/Equal Opportunity Employer

From: Mike Garneau [<mailto:mgarneau@wjmountford.com>]

Sent: Tuesday, October 16, 2018 1:15 PM

To: Shea Jeff

Cc: Mike Garneau

Subject: Simsbury Library RFI - 02

Hello Jeff – a couple more questions:

- 1) Can the Door Schedule be revised to show the correct frame sizes and correct other errors? See items #21 and #22 Addendum #1.
- 2) Per spec 062023, the specified cabinet manufacturer, Crown Point Cabinetry Co., is not bidding. There are no other companies listed in the spec. Can you provide another manufacturer?

Merillat Classic Series listed as second manufacturer, per item #5 Addendum #1.

Thanks,

Mike Garneau

Estimator

W. J. Mountford Co.

P 860-291-9448 x 124

F 860-289-6382

mgarneau@wjmountford.com

W.J. Mountford Co. is an Affirmative Action/Equal Opportunity Employer

PIONEER BUILDERS OF NEWINGTON INC.

CT License # 517085

AA/EOE

336 Stamm Road, Newington, CT 06111 Phone: (860) 666-2320 Fax: (860) 666-5156

REQUEST FOR INFORMATION

To: Jerome Shea

Date: October 11, 2018

Project: Simsbury Library

Location: 725 Hopmeadow Road, Simsbury.

1. Drawing AR100 shows a different location than drawing M100 for the wall cut out for the exhaust for AHU-1. Please confirm location.
Architectural drawing location is correct, a sketch to revise M100 will be issued in Addendum #2.
2. Drawing 1A400 shows a scale of 1/4" but it scales out as 3/8". Please confirm.
Revise Scale to be 3/8"=1'-0", per item 20 Addendum#1.
3. Spec 9.30.00 part 2.2B shows 12" x 18" wall but elevations on 1A400 show 12" x 12". Please confirm correct size.
Revise wall tile size to 12" x 12" per item #6 Addendum #1.
4. Drawing AR100 note 14 calls for plumbing fixtures to be replaced and to see P drawings. No P drawings were included. Please confirm new fixtures.
Specification provided on A100 see item #14 Addendum #1.

Thank you,
Jon Stockford

PIONEER BUILDERS OF NEWINGTON INC.

CT License # 517085

AA/EOE

336 Stamm Road, Newington, CT 06111 Phone: (860) 666-2320 Fax: (860) 666-5156

REQUEST FOR INFORMATION

To: Jerome Shea

Date: October 11, 2018

Project: Simsbury Library

Location: 725 Hopmeadow Road, Simsbury.

1. Drawing M100 shows 12" round ducts in the new meeting room ceiling that seem as if they won't fit in the space with the lighting. Please clarify.

The intent is maximize the height of the perimeter soffit, ductwork, lighting, and soffit framing and depth will need to be field coordinated.

Thank you,
Jon Stockford

PIONEER BUILDERS OF NEWINGTON INC.

CT License # 517085

AA/EOE

336 Stamm Road, Newington, CT 06111 Phone: (860) 666-2320 Fax: (860) 666-5156

REQUEST FOR INFORMATION

To: Jerome Shea

Date: October 11, 2018

Project: Simsbury Library

Location: 725 Hopmeadow Road, Simsbury.

1. Drawing A100 in the book sale storage has a type 1 wall against a concrete wall which is a wall sheetrocked on both sides. Is that correct?
Revise wall type tag to be 3, per item #12 Addendum #1.
2. Drawing A400 wall types lists a type 3A, 4A and 5A. I can't locate any of these wall types. Are they not used?
3A, 4A, and 5A are listed for reference only and are not used.
3. Is the difference between type 1/1A, 2/2A acoustical insulation versus no insulation? If so the wall types in the meeting room and exterior walls are uninsulated.
Classification 1A and 2A are for interior partitions requiring acoustic insulation. "All wall furring at existing exterior concrete foundation walls to receive batt insulation for continuous insulation plane." - per item #10 Addendum #1.

Thank you,
Jon Stockford

From: Estimating CT Carpentry [<mailto:Estimating@ctcarpentry.com>]

Sent: Wednesday, October 17, 2018 2:15 PM

To: Shea Jeff

Cc: Estimating CT Carpentry

Subject: 10-17-18 RFI #2 Simsbury Library Reno #2018-05

10-17-18 RFI #2 Simsbury Library Reno #2018-05

Are there Specifications for the Library Accessories?

Only Toilet Accessories are specified for this project.

Thanks,

Maurice "Moe" Villano

Connecticut Carpentry Corporation

Senior Estimator

860-571-8812 ,ext 306

Quotes to: estimating@ctcarpentry.com

Questions and correspondence to:

Mvillano@ctcarpentry.com jtibbetts@ctcarpentry.com



From: Maurice Villano [<mailto:MVillano@ctcarpentry.com>]
Sent: Wednesday, October 17, 2018 3:55 PM
To: Shea Jeff
Cc: Estimating CT Carpentry
Subject: 10-17-18 RFI #3 CT Carp Corp. Simsbury Library 2018-05

10-17-18 RFI #3 CT Carp Corp. Simsbury Library 2018-05

I don't recall clearly if You mentioned the MEPS specs would be coming with next Addendum, but my current search at ARC [plan room and my down loads shows no specs for MEPS. Please advise

Maurice "Moe" Villano
Senior Estimator
Connecticut Carpentry Corporation
mvillano@ctcarpentry.com
860-571-8812 Xtn 306

Electrical and Mechanical specifications are provided on the drawings, plumbing fixture specification is provided in item #14 Addendum #1.